

# Z'TOWER

## Notice de montage Assembly Manual

**Ce manuel doit impérativement être remis aux monteurs**  
**This manual must be issued to the scaffolding erectors**

102-61029518 - ind.03 – 12 / 2022



**Notice de montage / Assembly manual EN 1004-2 – FR - EN**

Français p.2 – English p.23

See QRCode for : Deutsch / Nederland / Español / Italiano / Português / Suomalainen / Svenska

Chapter 1: Scaffolding technical specifications ..... 24

    1-1 : Mark : ..... 24

    1-2 : Technical Specifications : ..... 24

    1-3 : Views of platform heights: ..... 25

    1-4 : Safety precautions for elevation, modification and use: ..... 27

Chapter 2: Assembly ..... 28

    2-1: Unfolding the base : ..... 28

    2-2 : Short rail : ..... 28

    2-3 : Platform : ..... 29

    2-4 : Stabilisers : ..... 29

    2-5: Rails : ..... 31

    2-6: Toeboards : ..... 32

    2-7: Elevation of the unit to 1,05m : ..... 32

    2-8: Elevation of the unit to 1,8m : ..... 34

    2-9: Locking Diagonal: ..... 37

    2-10: Lowering the unit: ..... 38

Chapter 3: After assembly and before use ..... 38

Chapter 4: Instructions ..... 39

Chapter 5 : Passing the base through a door ..... 41

Chapter 6: Verification, upkeep, maintenance and dismantling ..... 41

Chapter 7 : Dismantling ..... 42

Chapter 8: Environment ..... 43

Chapter 9: Guarantee ..... 43

## Chapter 1: Scaffolding technical specifications

### 1-1 : Mark :

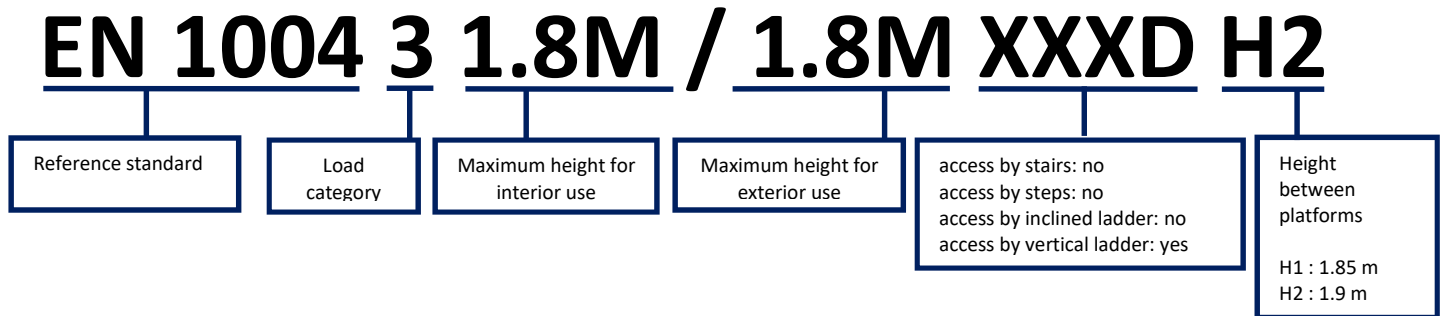

### 1-2 : Technical Specifications :

#### Construction :

Crimped aluminium structure

PLATFORM DIMENSION	
LENGTH (m)	1,30
WIDTH (m)	0,6
POINT LOAD (Kg)	150
ALLOWABLE LOAD (Kg)	156

#### Load structure:

- Point load: **150 Kg on a single loaded platform**
- Mobile access and working tower **category III EN 1004-1**
- Maximum allowable load on a single level: **2000 N/ m<sup>2</sup> (≈ 156 Kg) uniformly distributed on the platform**
- 1 person per platform (see platform details above)



**The use of stabilizers is compulsory  
for all mobile tower heights**



### 1-3 : Views of platform heights:

Platform Height: 0,3m

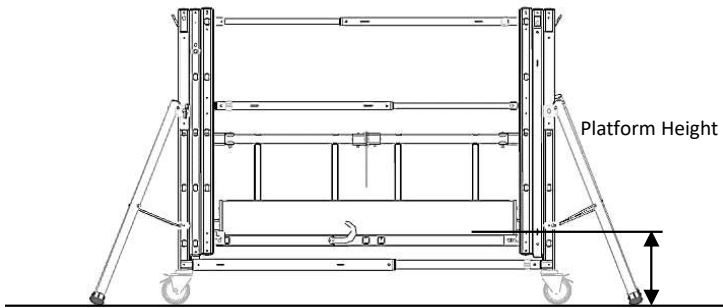

Platform Height: 0,55m

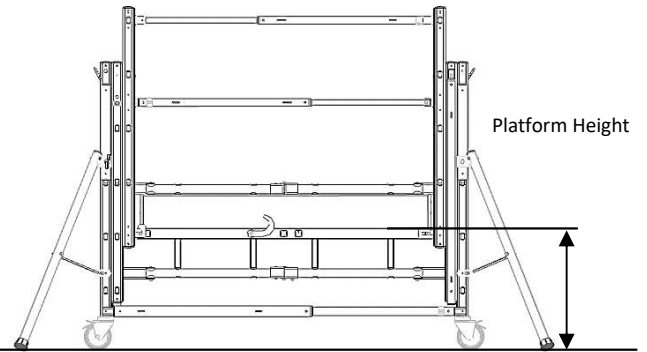

Platform Height : 0,8m

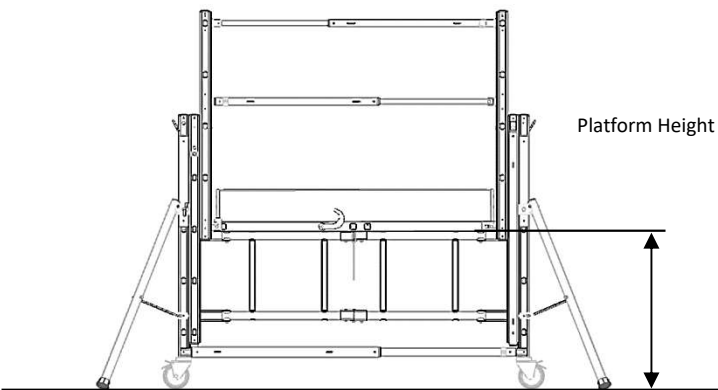

Platform Height: 1,05m

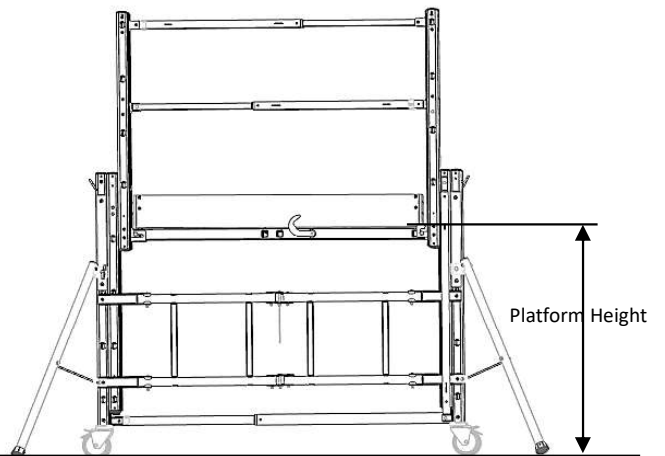

Platform Height : 1,3m

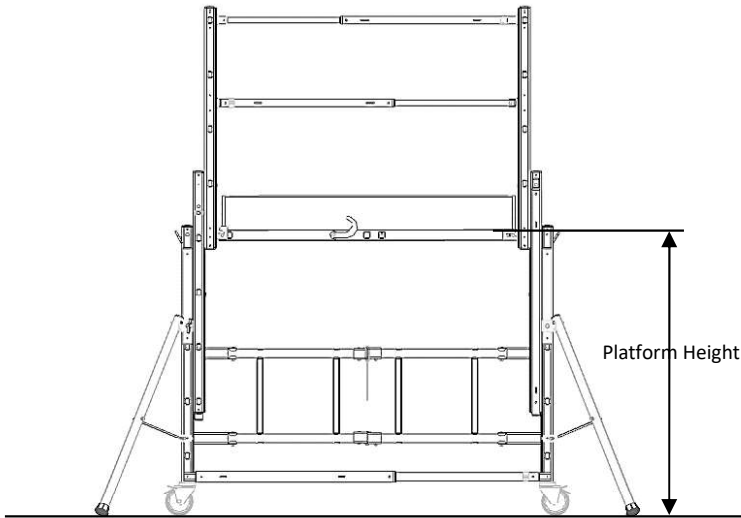

Platform Height : 1,55m

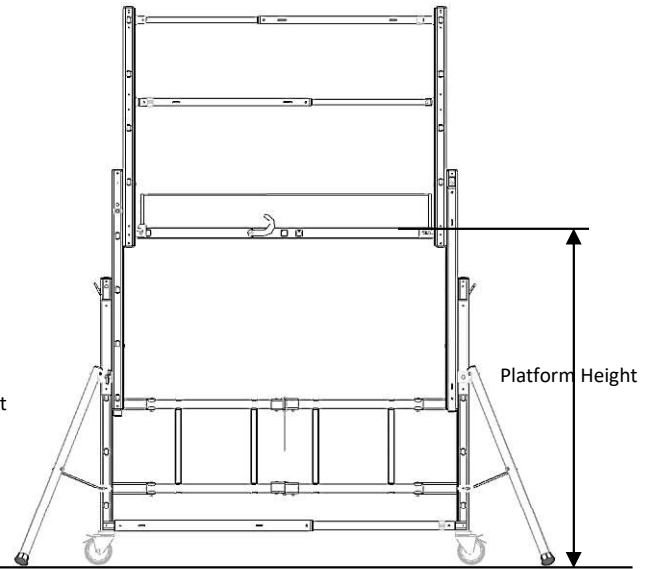

Platform Height : 1,8m

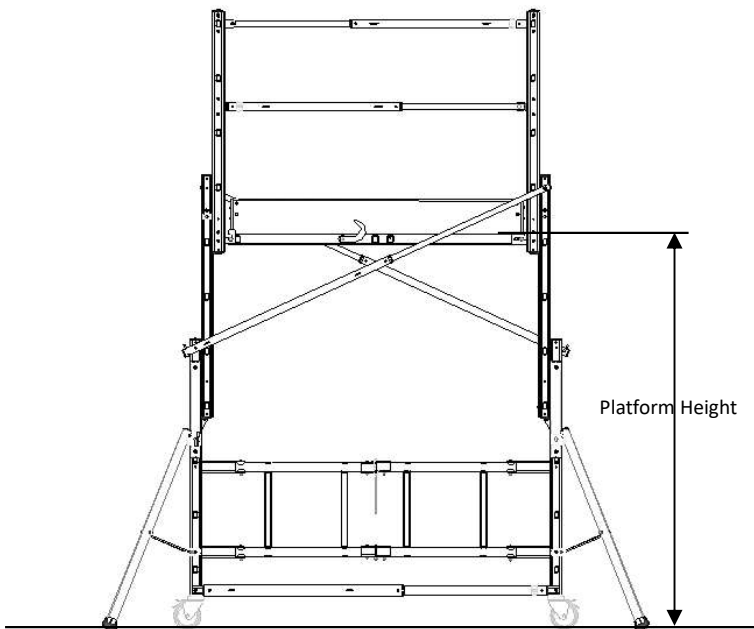

**WARNING : Diagonal must be set only at maximum height and be unset before setting at a lower height or folding the product**



**Platform height  $\neq$  working height - Adapt the platform height to the working area**

## 1-4 : Safety precautions for elevation, modification and use:

- The instruction manual should be available at the site where the mobile tower is being used.
- The mobile access and working tower should only be used in accordance with this manual, and should not be modified in any way.
- Mobile access and working towers should only be used in accordance with national regulations.
- The mobile access should be used intentionally as a means of accessing the working area.
- All components, tools and other necessary equipment to assemble the mobile access should be available at the site.
- Before assembling the mobile access and working tower, the chosen site should be checked to identify and prevent hazards during its assembly, modification and dismantling, including, and without limitation:
  - Ground conditions;
  - The level of the slope;
  - Obstacles (on the ground or in the air);
  - Weather conditions;
  - Hazardous electrical phenomena.
- Assemble the mobile access and working tower according to the instructions in this manual for assembly and use.
- Ensure that all necessary split pins and bolts are firmly in place.
- Z-TOWER should only be erected and dismantled by personnel trained in assembling and using the mobile tower.
- User training courses are not a substitute for instruction manuals, but can complement them.
- Only original TUBESCA-COMABI components, as specified in this manual, should be used.
- Damaged or faulty components should not be used.
- For assembling each element, refer to the previous diagrams in sections §1-2.
- PPE (Personal Protective Equipment) must be worn for assembly and dismantling.
- Stabilisers must always be positioned at an angle; refer to the diagrams and the table in the following sections §2-4.
- The Z-TOWER is design to be use and manipulate by one person only.
- Different levels can be accessed from inside the mobile tower via the trap door.
- Hauling up tools or other items whilst the product is in use can be done through platform access trap door.
- This product should only be used in accordance with the instruction manual.
- Mobile access and working towers designed in accordance with EN 1004-1 are not anchor points for fall arrest systems.
- Working on a platform is only allowed if there is a complete guard rail consisting of handrails, intermediate rails and toeboards.
- After assembly or modification, the following basic information should be displayed on the mobile access and working tower, and it should be clearly visible from the ground (on a label, for example):
  - The name and contact details of the person in charge;
  - Whether the mobile access and working tower is ready for use or not;
  - The load category and the uniformly distributed load value for the mobile access and working tower;
  - Whether the mobile access and working tower is solely intended for interior use only;
  - The assembly date.

Instructions drawn up following a risk assessment of Z-TOWER.

## Chapter 2: Assembly



### 2-1: Unfolding the base :

**1**

Locking castor wheel

Before starting: lock the brakes on the two wheels of the ladder with platform.

**2**

Remove the pin

Lock the brakes of the two other wheels.

X1

### 2-2 : Short rail :

**3**

(((CLICK))) X1



## 2-3 : Platform :

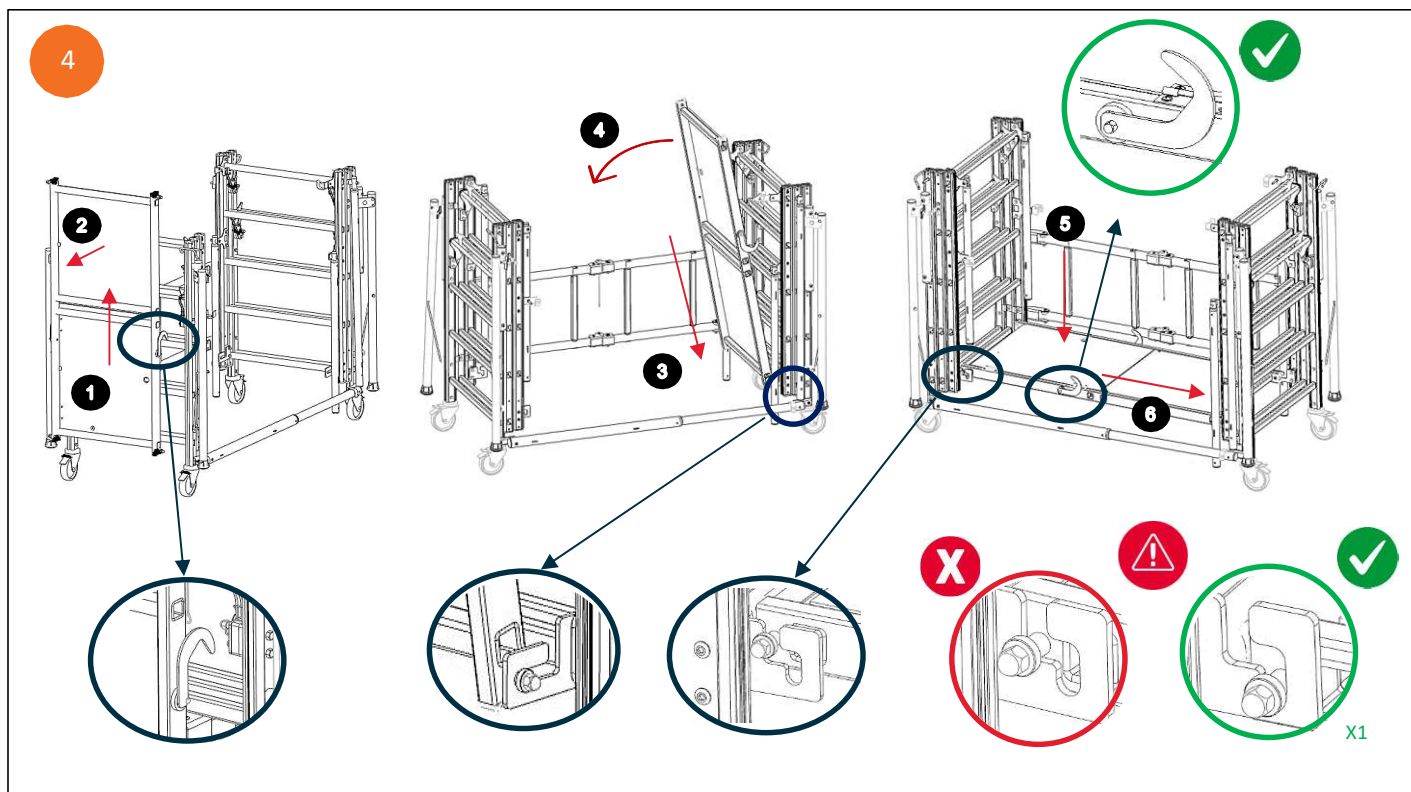

## 2-4 : Stabilisers :

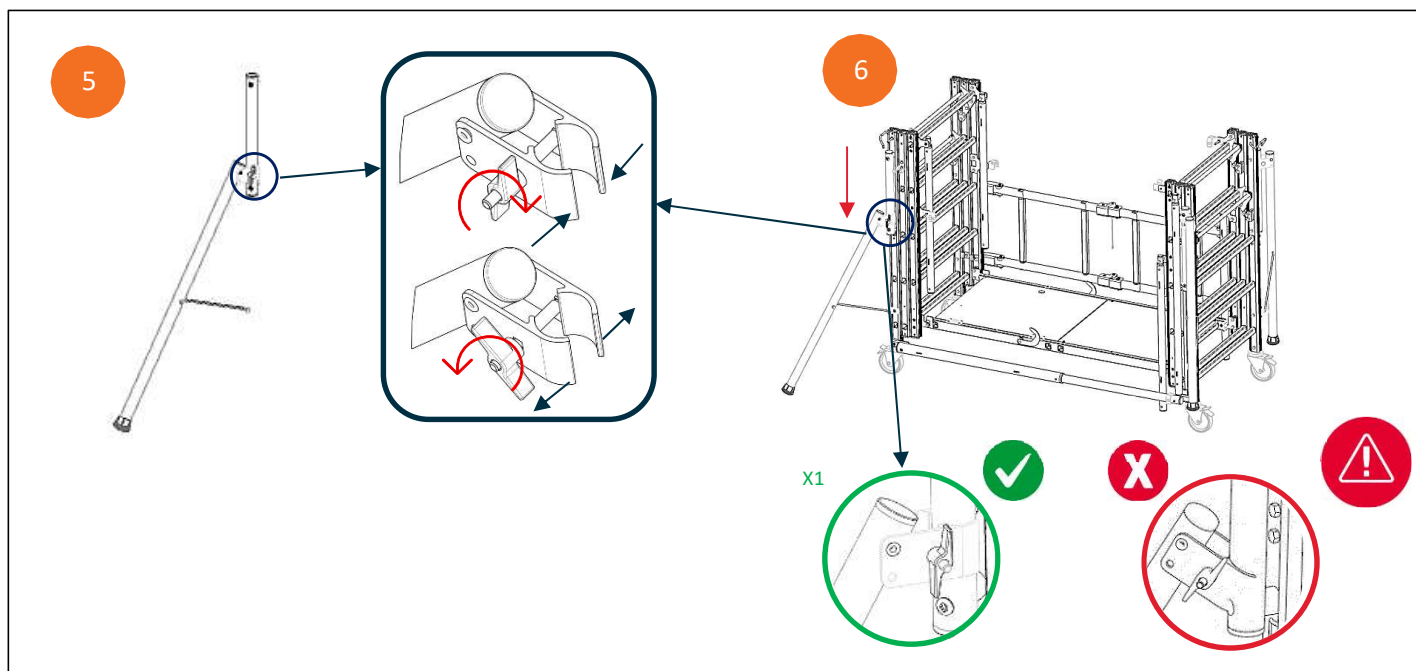



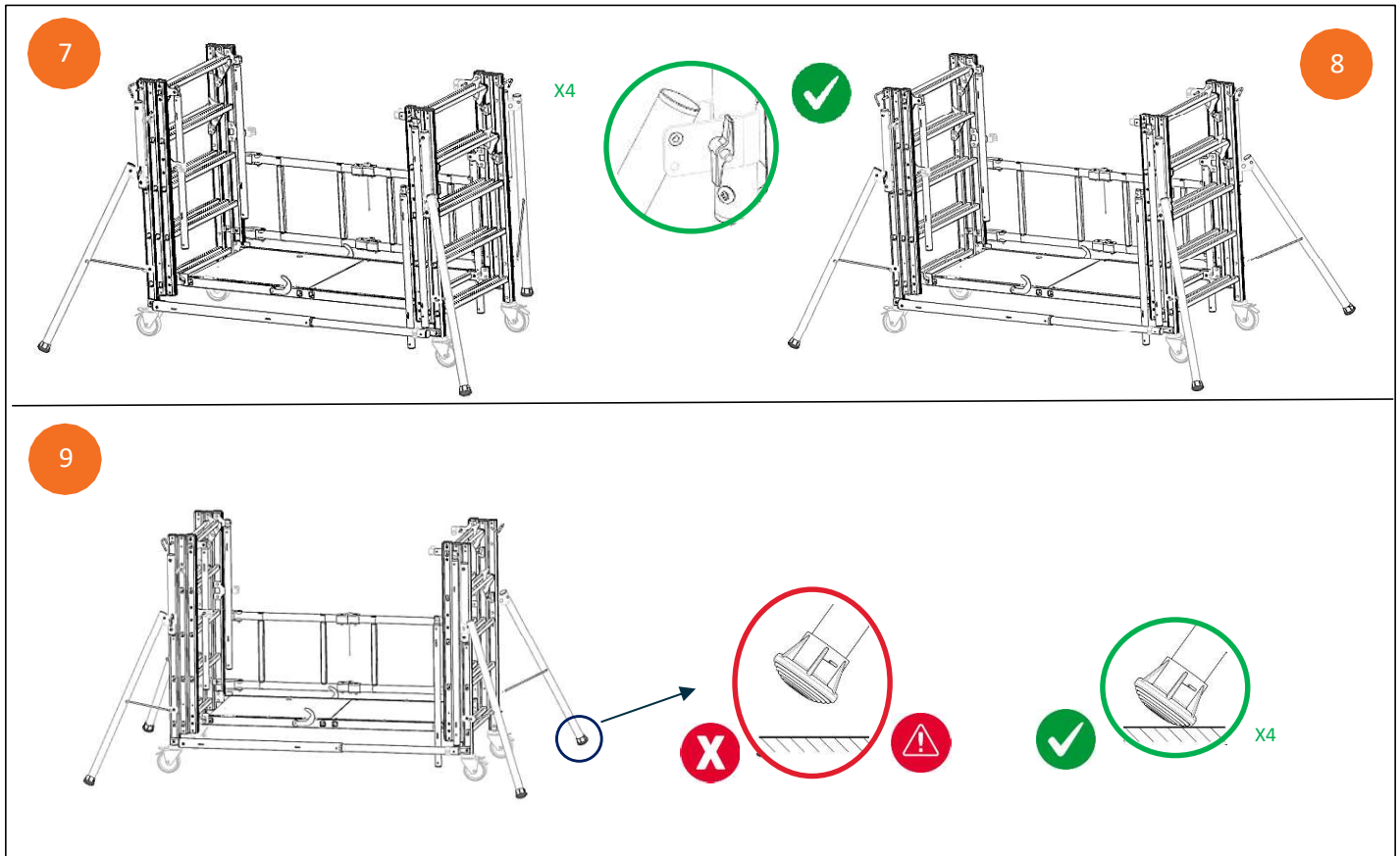

Before starting, check that the stabilisers do not move by ensuring that:  
 -the stabilisers are in contact with the ground  
 -distances and angles are in line with assembly procedures

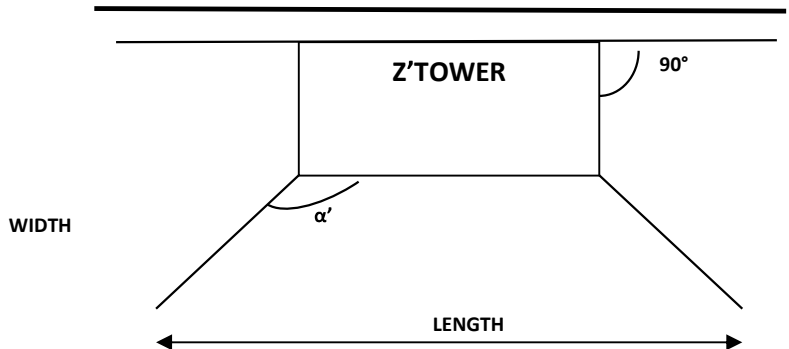
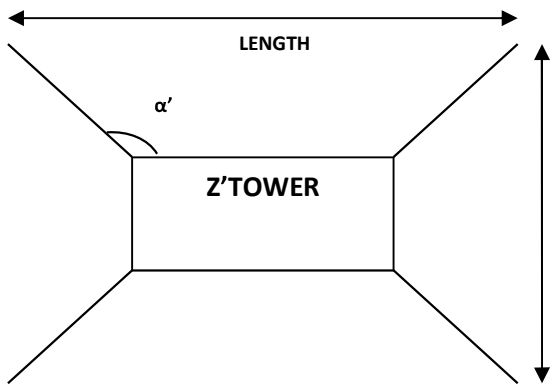

SABILIZERS POSITION		
LENGHT (m)	WIDTH (m)	$\alpha^\circ$
2,3	1,7	125

2-5: Rails :

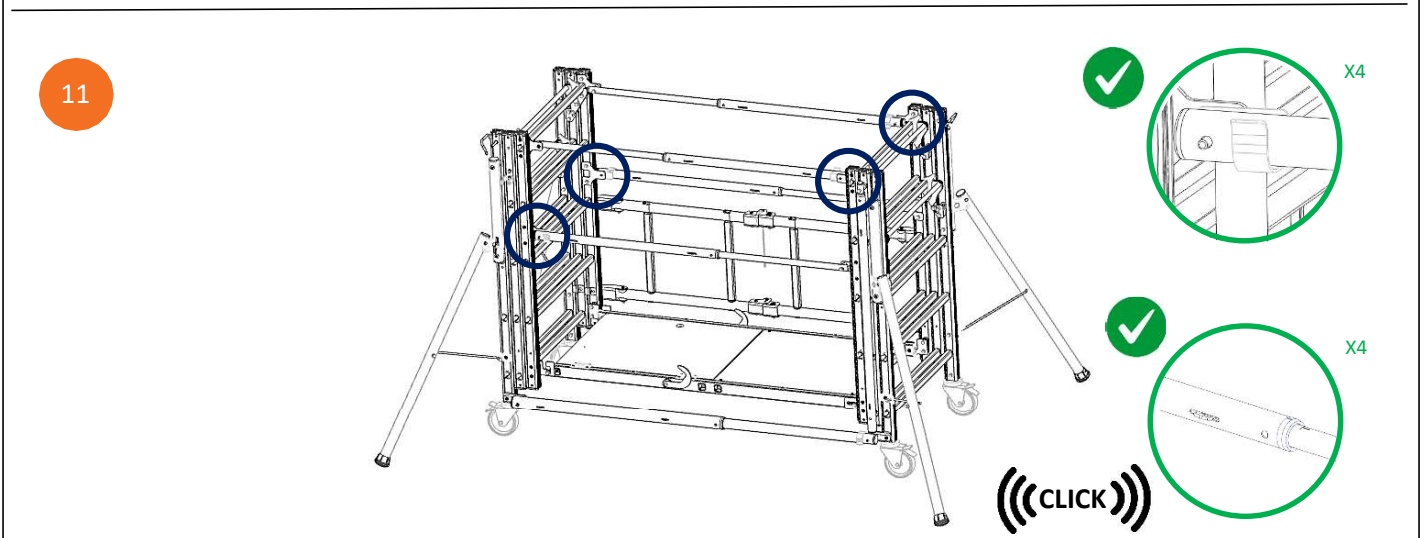
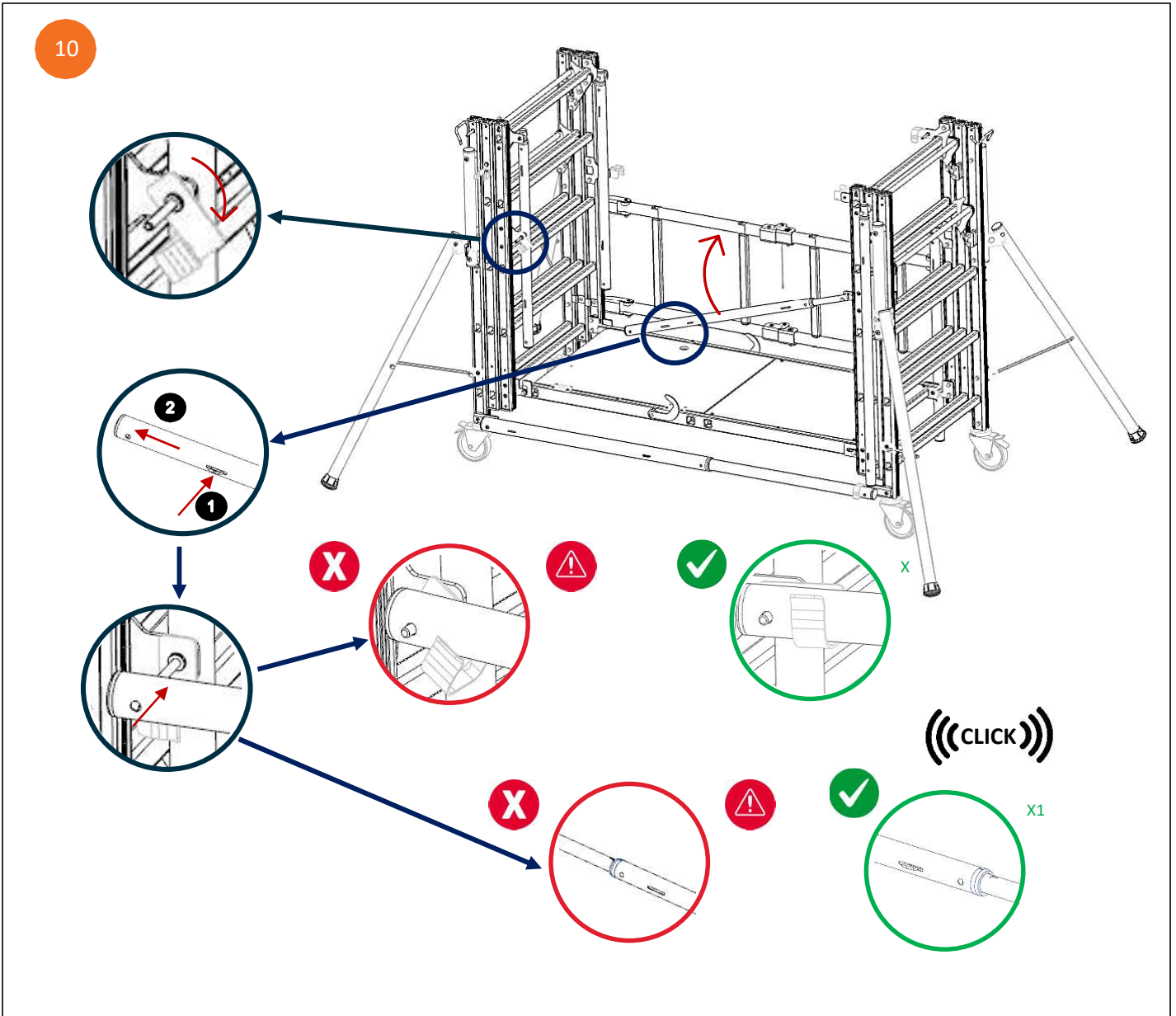

## 2-6: Toeboards :

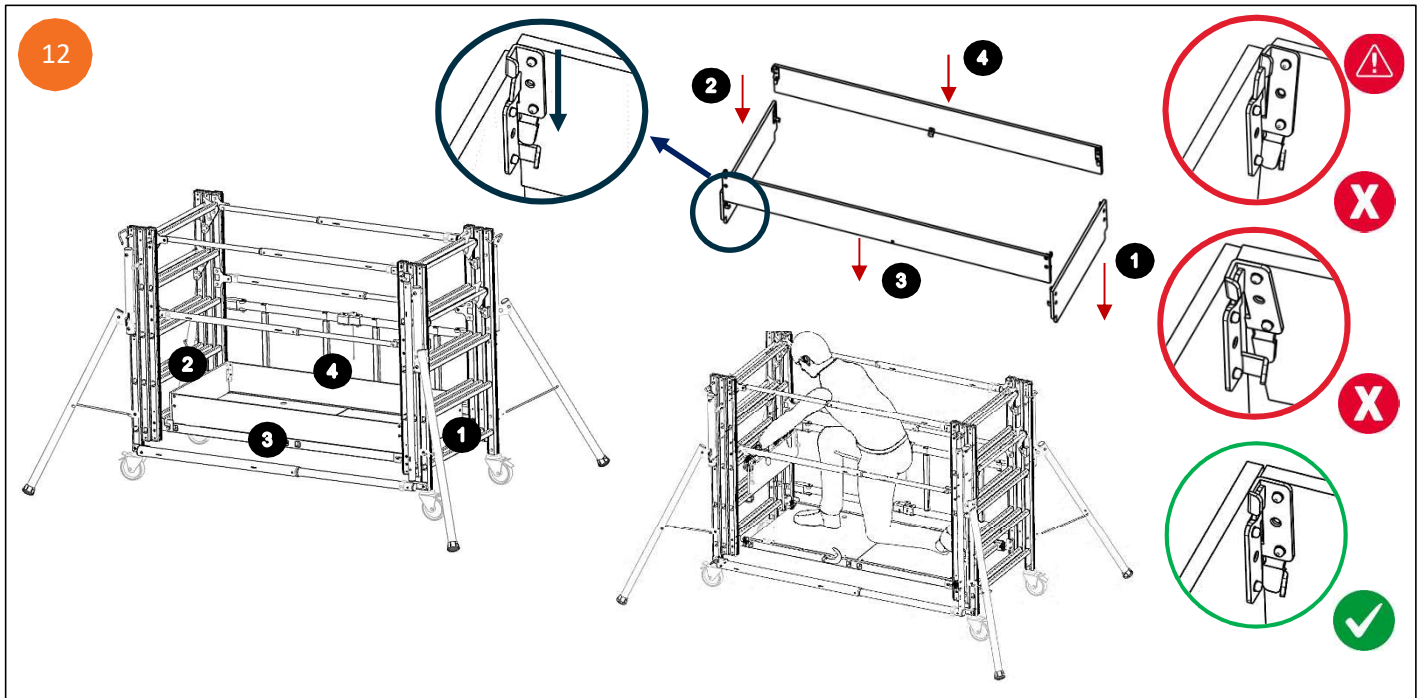

The product is ready for use at 0.3m.

## 2-7: Elevation of the unit to 1,05m :



Before starting, check that the lockers work properly when handling them.

The Z-Tower is assembled rung by rung, it is imperative to assemble both rungs to the same level before raising the platform to the next level. Put your foot on the lower rung to assemble the ladder.

Always assemble the inside ladders first.

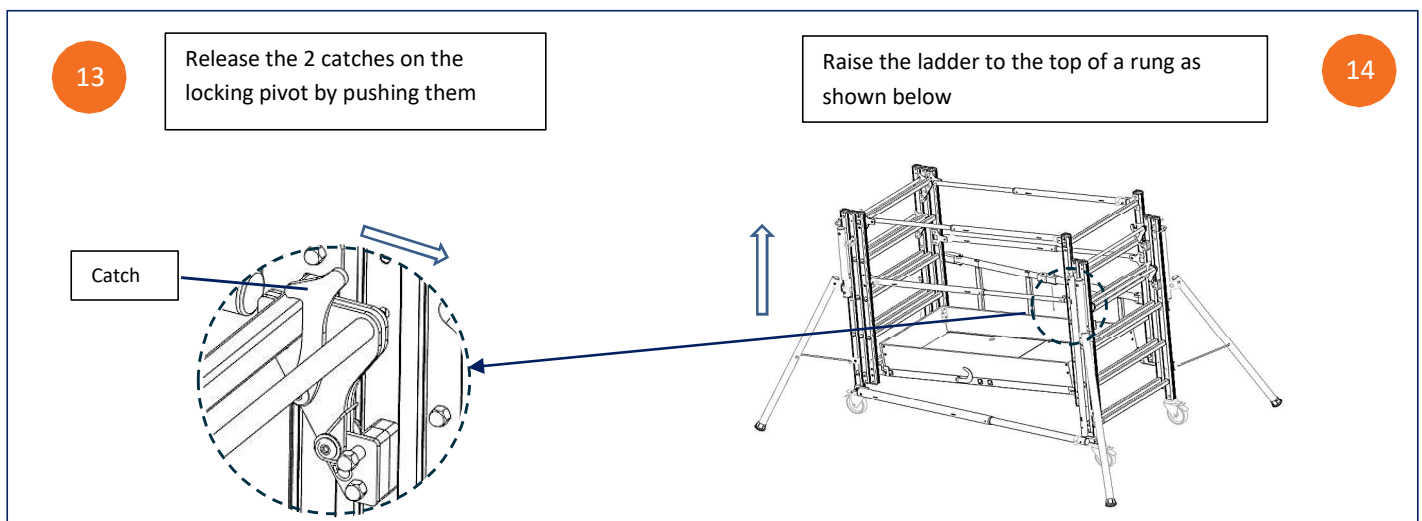

15

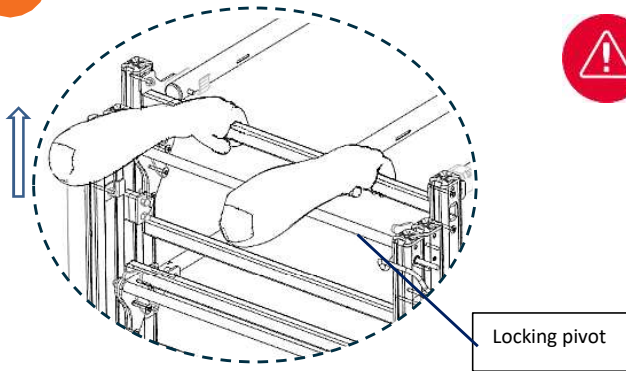

Do not put your fingers between the two ladders, hold the rung from above.

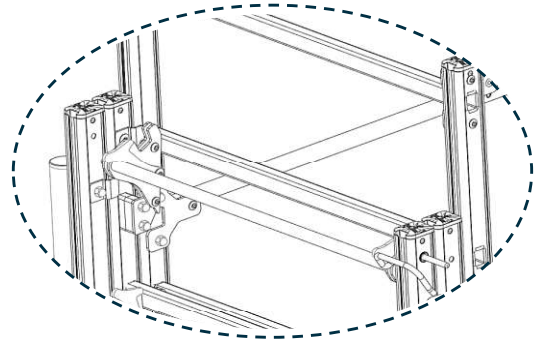

Raise the ladder without holding the locking pivot. It will move away automatically.

The locking pivot moves away when the next rung reaches it.

16

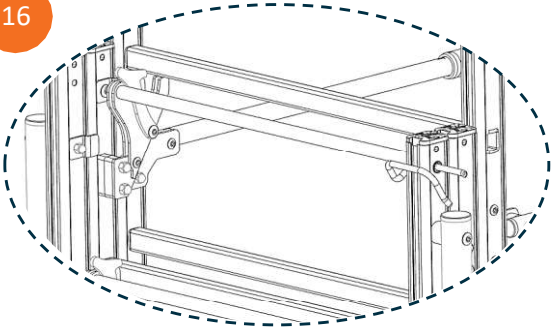

The locking pivot will come back into initial position one it is above the rung.

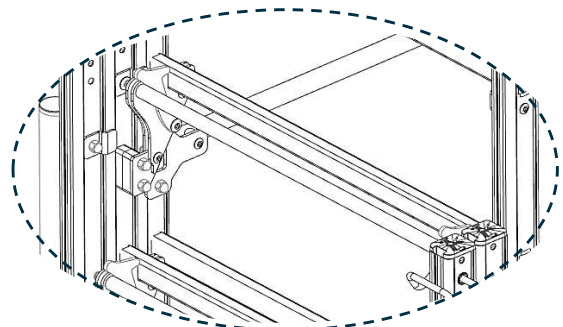

Lower the ladder until the locking pivot bears on the rung.

17

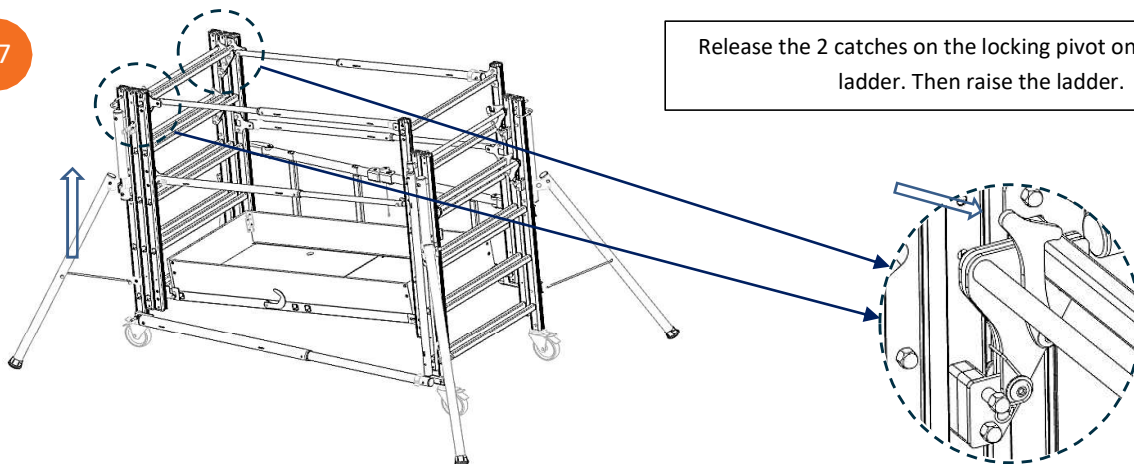

Release the 2 catches on the locking pivot on the opposite ladder. Then raise the ladder.

To reach a platform height of 0.55m, place the locking pivot on the rung directly above it and re-engage the catches on the locking pivot. For positioning the platform higher, place the locking pivot two rungs higher.



Raise the first ladder once again. To put the platform at a height of 0.8m, place the locking pivot on the rung directly above it and re-engage the catches on the locking pivot. For positioning the platform higher, place the locking pivot two rungs higher.

18

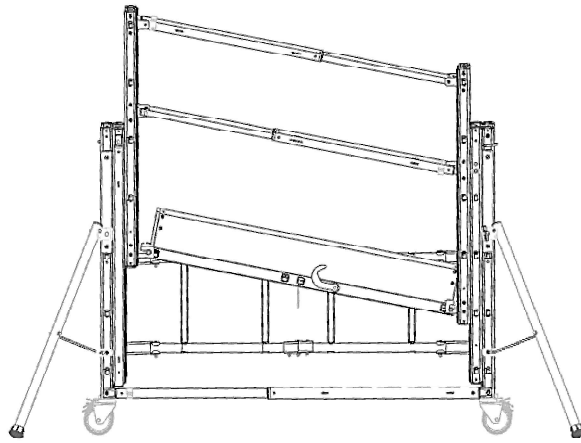

Raise the second ladder by a rung until you reach the maximum working height of 1.05m. The "STOP" labels on the locking pivot and the ladder will then be in line.

19

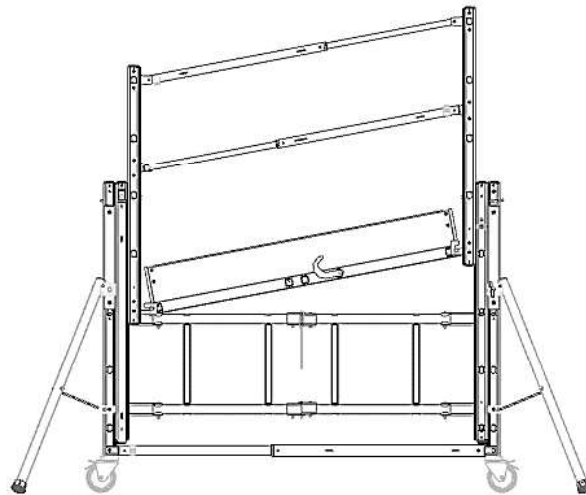

20



Engage the 4 catches on the locking pivots by pushing on them.

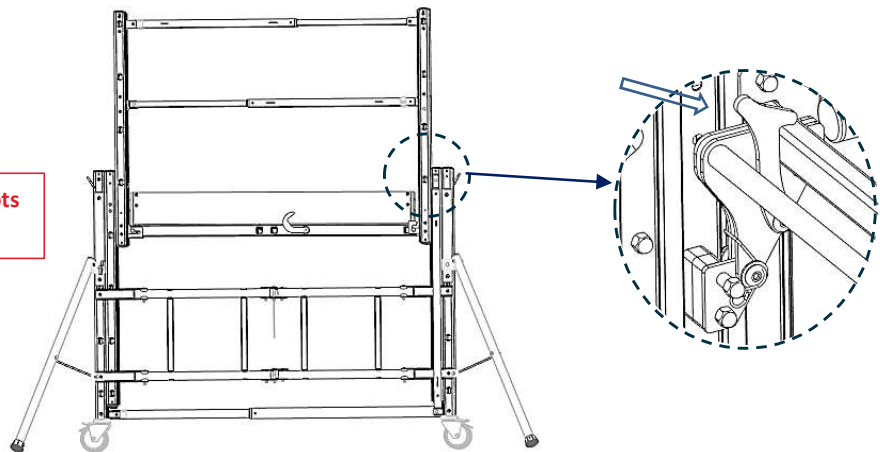

The scaffolding is now ready for use with a 1.05m platform height.

## 2-8: Elevation of the unit to 1,8m :

21

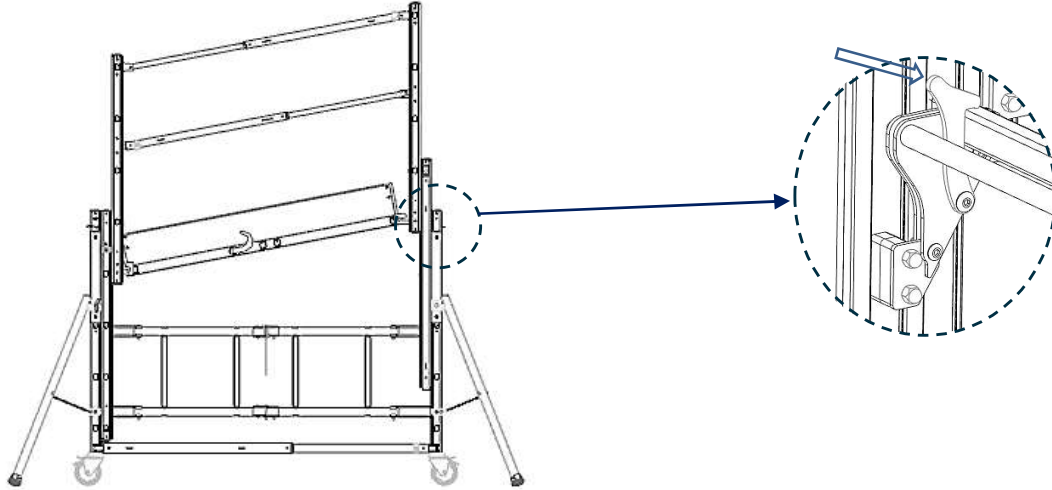

Disengage the two locking pivot catches on one of the two intermediate ladders.

Lift the ladder upwards until the locking pivot bears on the next rung.

22

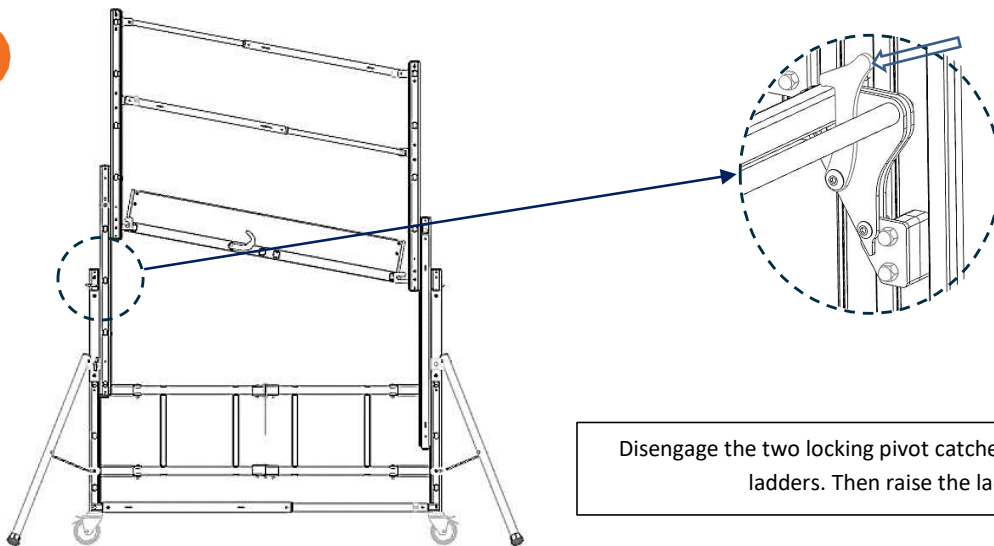

Disengage the two locking pivot catches on the opposite ladders. Then raise the ladder

To have a platform height of 1.3m, put the locking pivot on the rung directly above and re-engage the locking pivot catches. For positioning the platform higher, place the locking pivot two rungs higher.

23

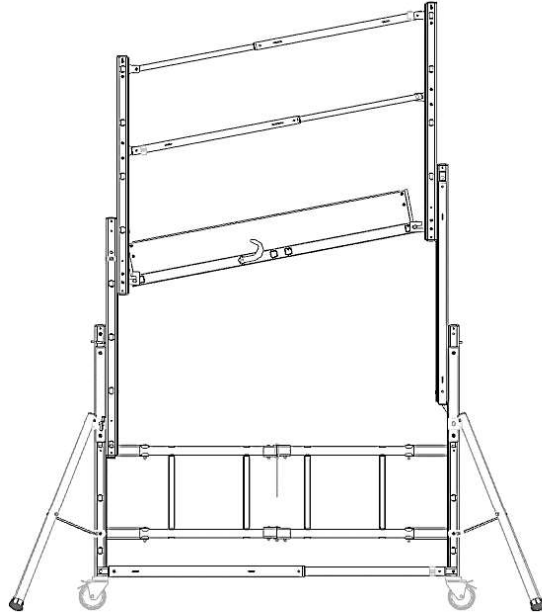

Raise the second ladder by one rung for attaining the maximum working height at 1.8m.

24

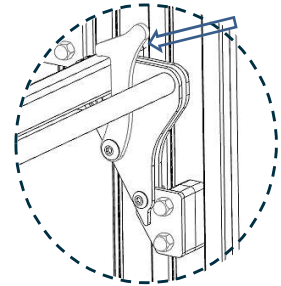
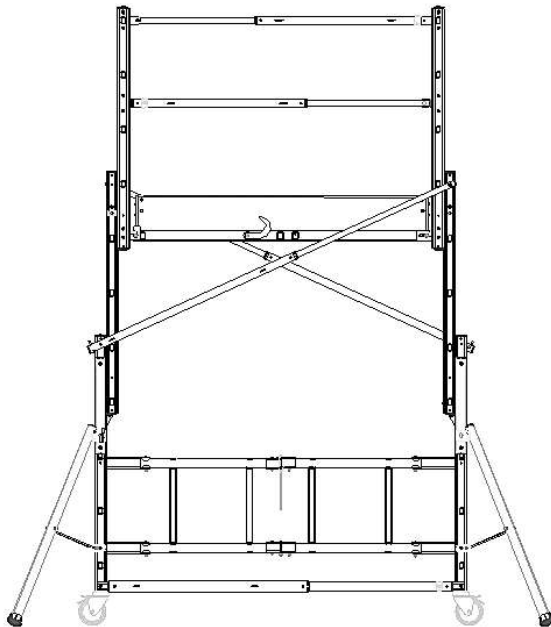

Engage the 4 catches on the locking pivots by pushing on them.

For use the platform at the maximum working height at 1.8m, it is compulsory to set up the diagonals, see §2.9.





## 2-9: Locking Diagonal:

**25**

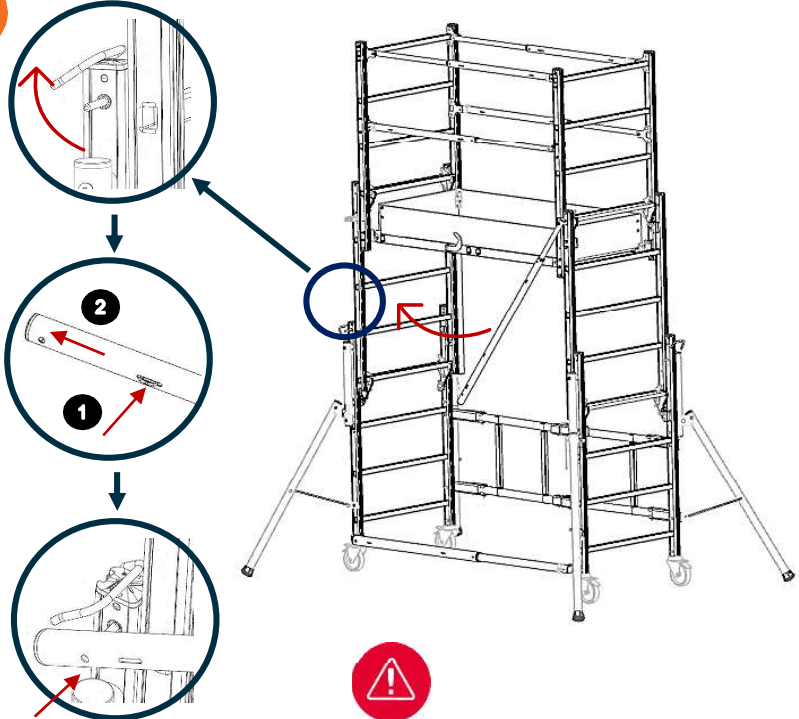

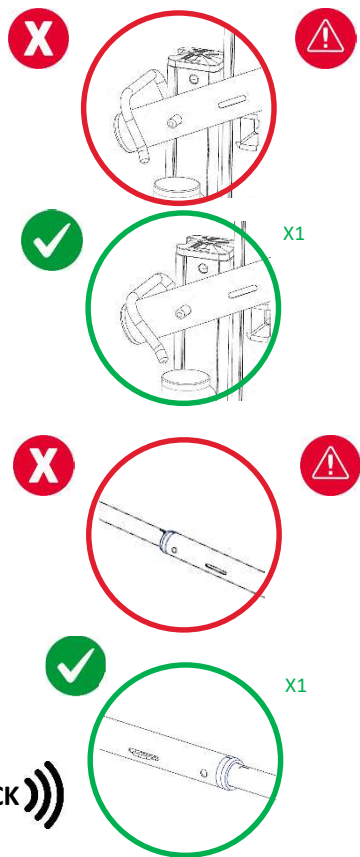

**(((CLICK)))**

**WARNING : Diagonal must be set only at maximum height and be unset before setting at a lower height or folding the product back.**

**26**

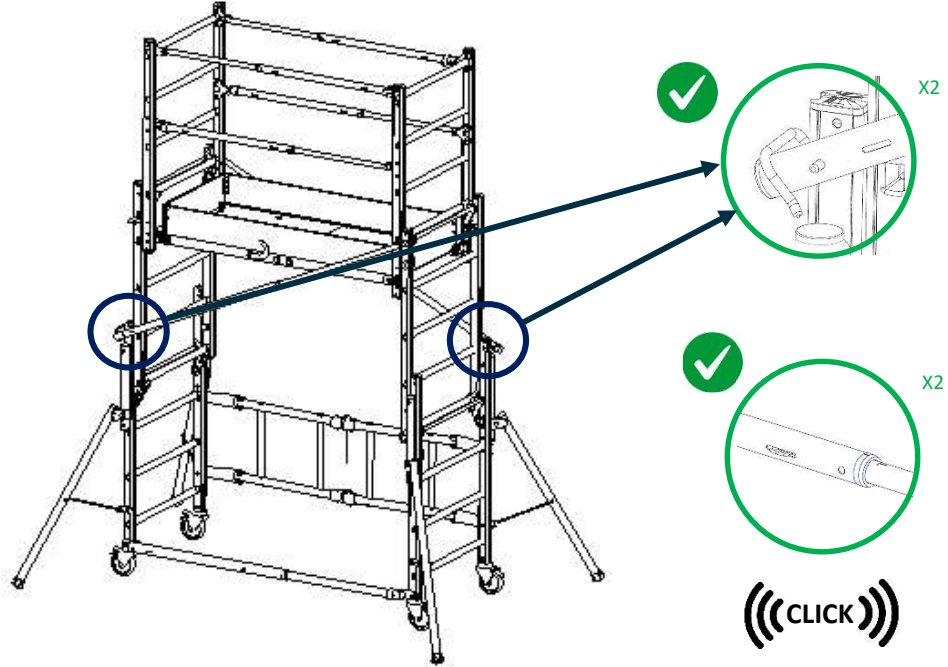

**(((CLICK)))**

The product is ready for use at 1,8m.

## 2-10: Lowering the unit:



If the platform is up to a height of 1.8m and the diagonals are up, it is necessary to fold them before down the ladders.

The lowering of Z-Tower is done rung by rung, it is imperative to up the two sides at the same level before starting the elevation of the platform to the next elevation.

Do not put your fingers between the two ladders, hold the rung from above.

Always lowering the intermediate ladders first.

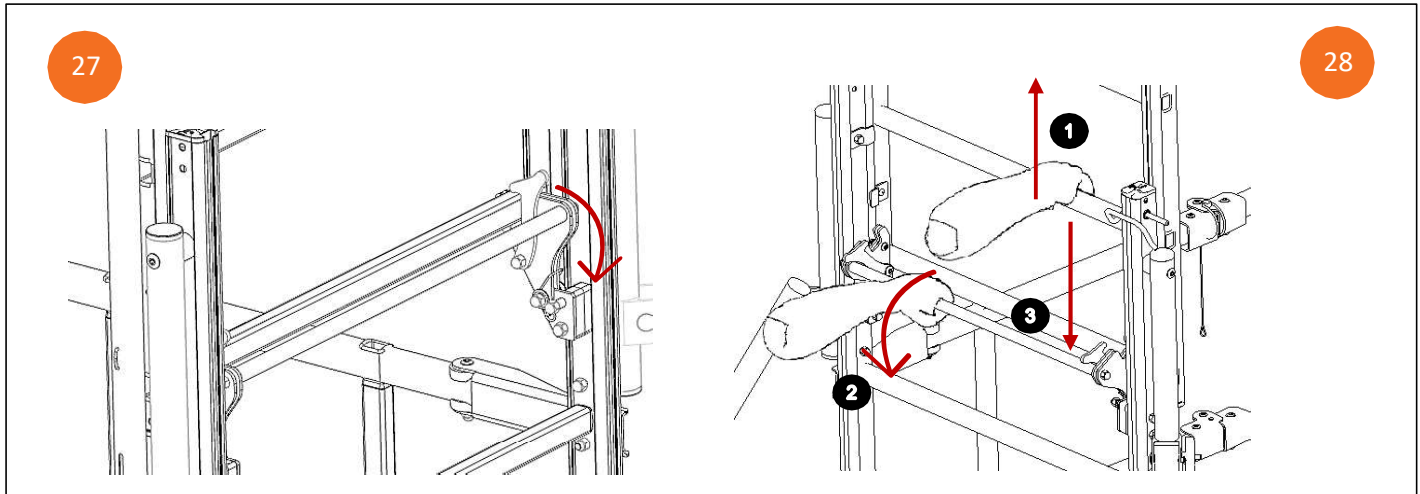

## Chapter 3: After assembly and before use

Correct assembly should be verified by the appropriately trained person who has been appointed by the company's on-site safety delegate.

The checks will cover:

- Whether the structure is in good condition.
- The completely assembled structure
- Verifying whether the mobile tower is correctly assembled and complete.
- Verifying whether the mobile tower is vertical or if it needs adjusting.
- Verifying that there is no environmental change which may affect the safe use of the mobile tower.
- Verifying that the stabilisers and the stabiliser legs comply with the instruction manual.
- The brakes (locked castors)
- The cushioning (to compensate for localised defects in flatness)







**ALWAYS** follow the instruction manual supplied with the product.

These instructions should be available at the site where the mobile access and working tower is being used.

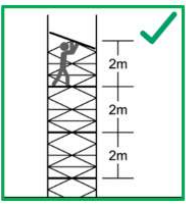
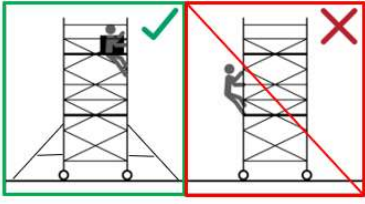
Check that the product, and particularly the safety devices, are in good general condition before each use (part condition and geometry). Where parts need to be replaced, only use TUBESCOMABI components: see manufacturer after-sales service sheet <https://www.tubescacomabi.com/fr/centre-de-documentation>, exploded views, after-sales service section.

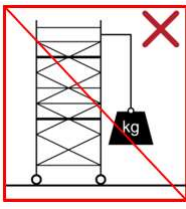
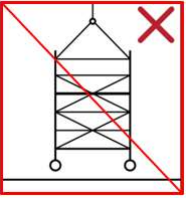
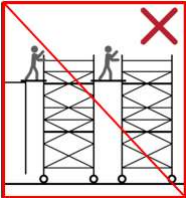
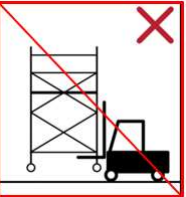
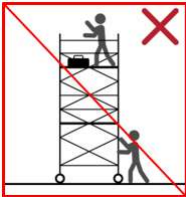
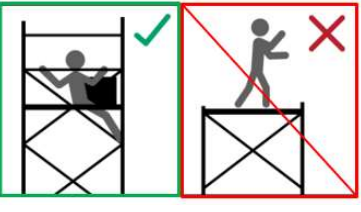
## Chapter 4: Instructions

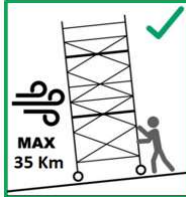
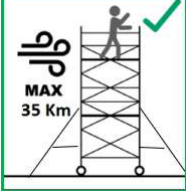
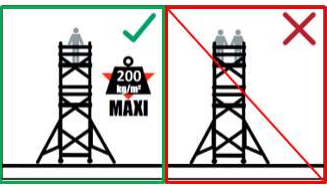
	<p>Allow 2 m between platforms when assembling and dismantling</p>		<p>Do not climb on the outside of the mobile access and working tower</p>
	<p>Do not use a ladder or anything else to increase the height of the tower</p>		<p>Do not suspend heavy objects from the mobile access and working tower</p>
	<p>Do not suspend the mobile access and working tower</p>		<p>Do not create walkways between mobile access and working towers or other structures</p>
	<p>Do not lift the mobile access and working tower with mechanical equipment</p>		<p>Do not move the mobile access and working tower when there are people or equipment on it</p>
	<p>Do not stand on an unsecured platform</p>		<p>Maximum tilt when moving the tower</p>
	<p>Maximum tilt when working on the tower</p>		<p>Maximum speed when moving the tower</p>
	<p>Maximum wind speed when working on the tower</p>		<p>Respect the allowable loads for the platforms and the structure</p>

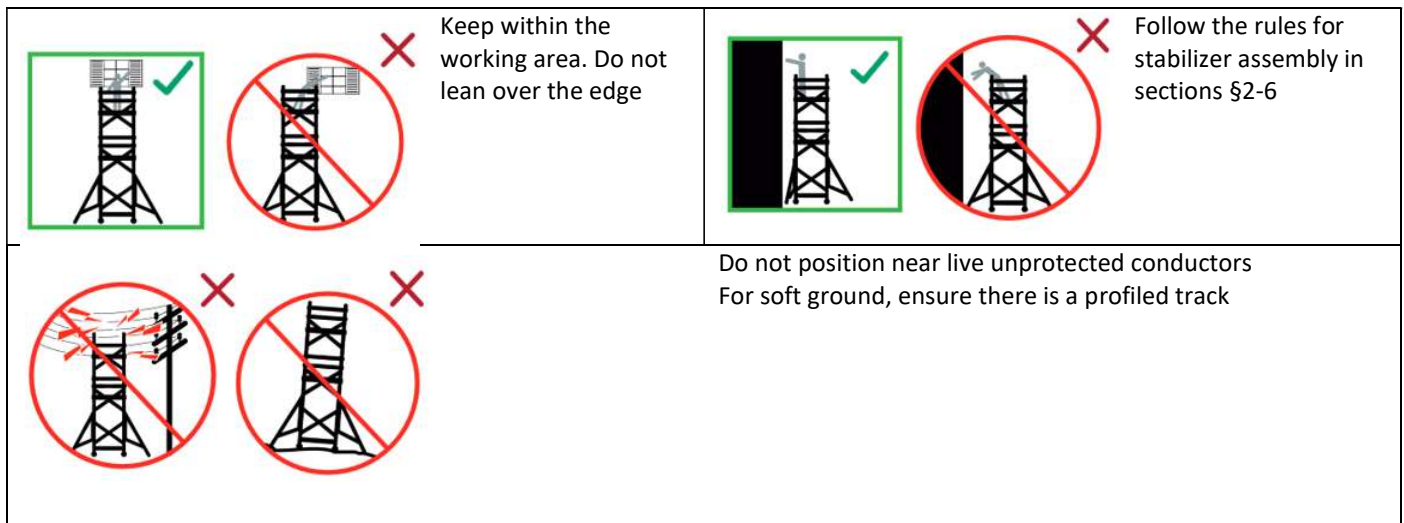

These instructions do not replace existing legislation which should be used as a reference.

- Respect allowable loads for the platforms and structure.
- Horizontal forces should not exceed 30Kg.
- Wind speed limit with stabilizers = 35 km/h.
- For wind speeds above 35 km/h: fasten down the mobile access and working tower.
- For wind speeds above 45 km/h: take down the mobile tower as shown in section §7.
- Do not position the mobile tower near live unprotected conductors.
- Prohibit access to the equipment when it is positioned in areas accessible to the public.
- Ensure there is sufficient signage at the site in case of traffic and vehicles....
- Check that there are no aerial obstacles in the movement area.
- Mobile access and working towers should only be moved manually whilst on firm and even ground, and where there are no obstacles either on the ground or in the air. The speed at which the mobile tower is moved should not exceed a man's normal walking speed. The mobile access and working tower to be moved should not exceed 1.8m in height, and no-one or material should be on the equipment whilst it is being moved.
- Keep the stabilisers fixed on the mobile access and working tower whilst it is being moved (The gap between the support plates and the ground should be reduced to a minimum).
- The ground on which the mobile access and working tower is being moved should be able to support load lowering.
- For soft ground (loose soil, gravel, etc.), ensure there is a profiled track.
- Z-TOWER can be moved by only one person: the mobile access and working tower is "PUSHED" as long as the maximum height acceptable specified by the manufacturer to move it is respected; it is not "PULLED".
- When the mobile access and working tower is left unattended, ensure that the stabilizers are working correctly (see section § 2.4), prevent all unauthorised access, and protect it from harsh weather conditions.
- Mobile towers are not designed to be covered in sheeting.
- Mobile towers with EN 1004-1 are not designed to be used as a means of peripheral protection.
- Mobile towers with EN 1004-1 are not designed to be used as a means of entering or exiting other structures, such as a staircase, for example.
- It is forbidden to:
  - Use a swing jib, even a manual one, on the outside of the mobile tower.
  - Cover the mobile access and working tower in sheeting, even partially.
  - Increase the height of the tower above the authorised height.
  - Use components other than the ones that have been supplied and described in the parts list.
  - Use damaged parts.
  - Use a mobile access and working tower which has not been assembled vertically (tolerance: 1%).
  - Use a mobile access and working tower which has not been assembled according to the instructions in this manual.
  - Create a bridge between a mobile access and working tower and a building, or between two mobile towers.
  - Lean an access ladder against the mobile tower.

- Jump on the platforms.
- Use boards as a platform.
- Move the mobile access and working tower on ground which is sloped more than 3%.
- Move the mobile access and working tower with a motor vehicle.
- Move the mobile access and working tower in wind speeds above 35 km/h.
- Move the mobile access and working tower when personnel or equipment are on it.
- Lift the mobile access and working tower with a crane or bridge crane.
- Keep hatches blocked open.

## Chapter 5 : Passing the base through a door

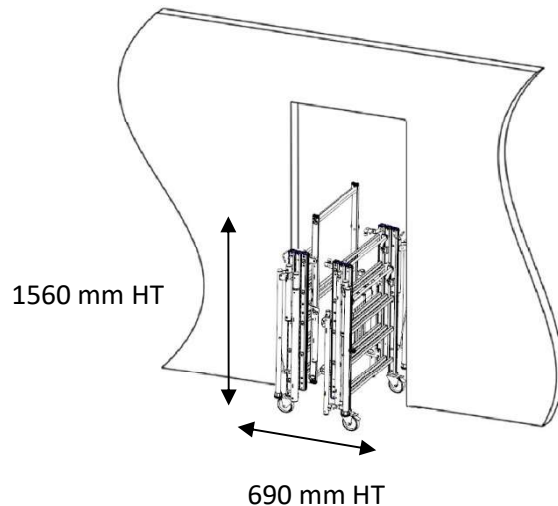

## Chapter 6: Verification, upkeep, maintenance and dismantling

- After use at each site, ensure that the mobile tower is cleaned with a clean cloth.

### Inspect parts before each assembly, particularly:

- Castor tyres and brakes.
- Safety devices.
- Working platform hooks and fasteners.
- The plywood on the working platforms.
- The stabiliser mounting brackets.

### All parts with the following defects:

- Permanent deformation.
- Perforations.
- Score marks (as a result of grinding, for example...)
- Severe oxidation

**... should be discarded!**

### If in doubt, change the part.

**When the part is being changed, it must be replaced with a genuine part.**

Keep parts clean, and safety devices in good working order.

Replace or clean all the panels or stickers with operating and safety instructions.

### Checks:

- This product should be checked periodically and the results of these checks should be recorded (see the manufacturer check sheet FV-22407-420).

Regulatory checks (provided for in the French decree of 21<sup>st</sup> December 2004) are outlined as follows:

#### **A check prior to use at each installation site:**

- when the mobile tower is used for the first time,
- when the mobile access and working tower is dismantled and then re-assembled.
- following changes in usage conditions, or atmospheric or environmental conditions which may affect the safe use of the mobile access and working tower,
- when the tower has not been used for at least a month.

This check should include a suitability assessment, an assembly and installation assessment, as well as an assessment of its condition. This check will be recorded in the establishment's safety records for traceability.

#### **A daily check**

This is a condition assessment.

This check will be recorded on a sheet attached to the access hatch for traceability.

#### **A quarterly check**

For the mobile access and working tower, the scope of this check is comparable to the daily check. It will be carried out at least once every 3 months, and will be recorded in the establishment's safety records for traceability.

**Nota bene:** These checks can only be carried out by personnel holding a certificate of competence entitled "Checker and User" which has been issued by company management.

For more information and details regarding checklists, please refer to RECO R.457, annex 3, 3bis, 4, 5, 6.

## Chapter 7 : Dismantling

- Before dismantling:
  - Ensure that the mobile access and working tower is stable.
  - All parts, tools and other necessary equipment to dismantle the mobile tower should be available on site.
  - The brake castor wheels are locked.
  - The stabilisers are correctly positioned etc...
- Before handling:
  - Put the pins back on to the components.
  - Put damaged parts to one side to be replaced.

- During dismantling:

Use the procedure for assembling the tower in strict reverse order. **Make sure the stabilisers are not dismantled first.**

**If the platform is erected to a height of 1.8m and the diagonals are in position, it is necessary to fold them before lowering the ladders.**

Store the mobile tower in a dry, unobstructed, secure place where it is not at risk of getting damaged or being in the way.

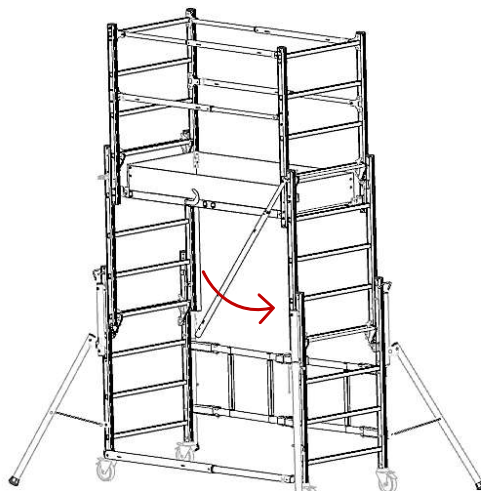



## Chapter 8: Environment

Z-TOWER is mainly made of aluminium. Other materials, like steel, plastic and wood, form integral parts of the product. All the materials used are recyclable.

At the end of product life, the materials used to make the tower should be sorted and then disposed of. As end consumer, your role in the reuse and recycling of products is vital. Ensure that the product is taken to an authorised waste collection centre.

## Chapter 9: Guarantee

The guarantee is effective from the date of invoice.

Our guarantee is subject to the purchaser fulfilling their contractual obligations, especially payment.

The guarantee is limited to factory replacement or repair of original parts, which have been identified as defective following our inspection.

All further claims are excluded. More specifically, applying the guarantee will in no way result in the payment of damages.

This guarantee only applies to products which have been installed and used in accordance with the installation and operation instructions in the technical manual.

**IMPORTANT:** keep your proof of purchase in a safe place (invoice or delivery note) as you will be asked for it in order to apply the guarantee.

For further information, visit our website at:

[www.tubesca-comabi.com](http://www.tubesca-comabi.com)





Retrouvez la notice dans votre langue via le QRCode ci-dessus ou sur votre produit.

Find out the instructions in your language via the QRCode above or on your product.

Finden Sie die Anleitung in Ihrer Sprache über den QRCode oben oder auf Ihrem Produkt.

Find out the instructions in your language via the QRCode above or on your product.

Encuentre las instrucciones en su idioma a través del QRCode anterior o en su producto.

Löydät ohjeet omalla kielelläsi yllä olevasta QRCodeista tai tuotteestasi.

Trovate le istruzioni nella vostra lingua tramite il QRCode qui sopra o sul prodotto.

Vind de instructies in uw taal via de QRCode hierboven of op uw product.

Encontre as instruções na sua língua através do QRCode acima ou no seu produto.

Hitta instruktionerna på ditt språk med hjälp av QRC-koden ovan eller på din produkt.