

AH199

Furring to Channel Clip (MF9)

Technical Datasheet

Application

Furring to Channel Clip



Technical Details

Material EN 10270:01 High Carbon Wire

Thickness 2.64mm

Surface Finish Galvanised coat to EN10244 Class D

Wire Tensile: 1420 to 1640 M/mm²

Load Test 0.47kN

Maximum Safe Working Load 0.117kN

Safety Rating 4:1

Fire Rating N/A

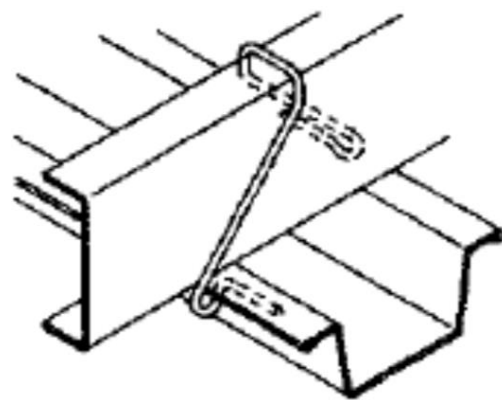

Health & Safety

As with all metal products, there is a risk from sharp corners or edges. Appropriate PPE should be used. Repeated contact with metal coatings may cause skin irritation.

Arthur Hough & Sons Limited
Hilton Cross Business Park, Cannock Road
Featherstone, Wolverhampton WV10 7QZ
Tel: 01902 867717 Fax: 01902 867719
Email: sales@ahough.com Website: www.ahough.com