

INDUCTION HEATER

DHI0044



Operating and Maintenance Manual

**BUTTSOF
BAWTRY**
ESTABLISHED SINCE 1971

CONTENTS

1	INTRODUCTION	4
2	SAFETY INSTRUCTIONS	4
2.1	GENERAL USE WHEN USING DH10044	4
2.2	INFORMATION SYMBOLS	5
2.3	SYMBOLS INDICATED HEALTH RISKS	6
2.4	SYMBOLS WARNING WHILE HANDLING THE DEVICE	7
3	PERIODIC INSPECTION AND MAINTENANCE	8
4	STORAGE.....	8
5	WARRANTY PROVISION	8
6	COMMISIONING	9
6.1	UNPACKING AND FIRST START	9
6.2	COOLANT REFILLING.....	10
7	REPLACEABLE HEATING INDUCTOR EXTENDERS.....	10
7.1	HEATING INDUCTOR EXTENDER REPLACEMENT PROCEDURE	10
8	ABOUT THE DEVICE AND HEATING	10
8.1	SUPPORTED TECHNOLOGIES	10
	DHCS3 - Heating Control System 2	10
	DIPA - Dynamic Induction Power Adjust	11
8.2	HEATING MODES AND THEIR APPLICATION.....	11
8.3	CONTROLLED HEATING	12
	Using the heating timer	12
9	DEVICE CONTROLS.....	12
9.1	DESCRIPTION OF DEVICE COMPONENTS.....	12
10	ACTIVATING THE DEVICE	13
11	STANDBY.....	14
12	HEATING TIMER.....	14
13	LIST OF ERRORS MESSAGES.....	15
14	TECHNICAL PARAMETERS.....	15
15	ELECTRIC SCHEME	16
16	DECLARATION OF CONFORMITY	16
17	SAFETY SHEET OF COOLANT LIQUID.....	17
18	USED DEVICE DISPOSAL.....	21
19	SPARE AND CONSUMPTION PARTS.....	21
20	QUALITY CERTIFICATE.....	22
21	WARRANTY SERVICING.....	22

22 WARRANTY CERTIFICATE.....23

1 INTRODUCTION

Dear Customer, thank you for your trust and Purchase of this DH10044 Water Cooled induction Heater. We believe that you will be fully satisfied with the product for many years to come.

In case of any questions or comments do not hesitate to Contact us either on our website or Contact your sales representative directly.

The first use of the device is the purpose of this legal step instructions, which the user confirms their free will, that this instruction properly studied, fully understand its meaning and familiar with all the risks.



ATTENTION! Do not attempt to place (or use) the Equipment before you become familiar the entire operating instructions. Keep the instructions for future use.

2 SAFETY INSTRUCTIONS

2.1 GENERAL USE WHEN USING DH10044

Symbols shown in this Manual warn and identify potential hazards when handling the device.

- Do not leave DH10044 unattended while it is turned on. Always deactivate the unit by the master switch when not using it for heating!
- Make sure that the power supply unit has sufficient air supply for cooling
- Make sure that the ventilation openings are clean and free of dust and dirt, to not preclude flow of cooling air.
- Do not attempt to repair your inductor - The device contains no user-reparable components .
- The user is responsible for the system installation and use in accordance with instructions shown in this Manual. The supplier is not liable for any damage due to inexpert use and operation.
- **Only persons older than 15 years, properly trained and with adequate qualification can operate the equipment. Do not use the equipment when under the influence of drugs, alcohol or medication.**
- Keep persons standing around and animals at a safe distance while working with the device, including while the heated material is cooling down.
- Avoid working in rain, water and humid environments. Keep the working area well ventilated and dry, clean and well lit.



SYMBOL	EXPLANATION
	DANGER! Denotes a dangerous situation that will result in a death or serious injury. The potential risks are shown under the following symbols, or explained in the text.
	Before plugging in your DH10044 make sure the socket voltage matches that on the product plate. If the socket voltage does not match that shown on the type plate, it can result in a serious hazard and damage to your unit.
	IMPORTANT! Read this Manual carefully to gain information about the device features. Inappropriate handling may cause injuries to persons and damage to the device.





NOTICE: This equipment is not designed for use in residential environments and may not provide adequate protection of radio reception in such environments.

2.2 INFORMATION SYMBOLS





The symbols shown below will guide you through this Manual and warn you of potential risks. If you see the symbol, be careful! Follow the instructions shown below to avoid the dangers. Read all the safety notifications and follow the instruction shown below.

You will find more safety instructions in bellow.



SYMBOL	EXPLANATION
	Risk of death by electrocution.
	CAUTION! Hot surface! Risk of burns!





SYMBOL	EXPLANATION
	CAUTION! Risk of electric shock!
	Risk of fire.
	Electromagnetic field risk.
	Do not use cardiac pacemakers, implanted devices and watches or other metal objects.
	Always use! Protective goggles, protective masks and protective gloves.

2.3 SYMBOLS INDICATED HEALTH RISKS

<p>2.3.1</p> 	<p>ELECTRIC SHOCK</p> <p>CAUTION! Never remove casing and do any activity with the induction heater unless you have first disconnected the plug from the socket. Then wait at least 1-2 minutes after unplugging it.</p> <p>DO NOT OPERATE THE EQUIPMENT IN RAIN AND IN MOIST ENVIRONMENTS.</p> <p>CAUTION! Any and all interference with the electrical section may only be made by persons with adequate electrical engineering qualification. Any unauthorised servicing work poses the risk of electric shock.</p>
<p>2.3.2 CAUTION!</p>  	<p>HOT SURFACE</p> <p>CAUTION! Do not touch any objects located near the induction heater unless you have checked that it has cooled down.</p> <p>Do not touch the induction coil if it is activated and the strong magnetic field and heating are turned on.</p> <p>ALWAYS wear protective gloves or other protections when handling the device as there is a risk of burns. Protective equipment is specified in text below.</p>
<p>2.3.3</p> 	<p>RISK OF FIRE</p> <p>DO NOT OPERATE THE EQUIPMENT IN ENVIRONMENTS WITH AN EXPLOSION HAZARD!</p> <p>Do not overheat parts. Do not heat materials above their melting point; in such cases, there is a risk of being spilled with hot metal and burns. Be careful about fire if the device is kept near one. Keep inflammable substances outside the working area. Do not put the device on, over or near inflammable surfaces. Do not use the machine if it is near objects that may contain inflammable particles of dust, gas, vapour or liquids. After completion of work with the device, check the area to make sure everything is secure and there is no risk of sparks, flames and fire.</p>

2.4 SYMBOLS WARNING WHILE HANDLING THE DEVICE

2.4.1 SAFETY EQUIPMENT WHEN WORKING WITH THE DEVICE	
	Always wear protective goggles or face mask when using the DHI0044
	Use of the device may produce dangerous waste gases from burning of old paints, lubricants, sealants, glues, etc. These exhausts may be toxic. Always use adequate protective masks or respirators.
	Always use protective gloves with adequate thermal resistance when working with the device. The high temperatures produced by using the DHI0044 may cause serious burns on contact with the heated part.

2.4.2 ELECTROMAGNETIC EFFECTS	
	<p>The electromagnetic field (EMF) may affect implanted medical devices. The device is not intended to be used by users of cardiac pacemakers or other implanted medical devices.</p> <p>While working, maintain a safe distance between body parts and the heated inductor, as specified in its instructions for use.</p>
	<p>Short-term tissue exposure to high-intensity time-variable magnetic field may lead to tissue warming by the induced current.</p> <p>Long-term exposure to high-intensity time-variable magnetic field may lead to</p> <ul style="list-style-type: none"> -undesirable effects on nerve activity -fatigue -headaches -blood cell production disorders
	<p>Persons with other metallic or electronic surgical implants are not allowed to work with the DHI0044 and have to keep a safe distance of at least 1 m from the device.</p>
	<p>When working with the DHI0044, do not wear any metal objects such as jewels, rings, watches, necklaces, identification plates, belt buckles, piercing or clothes with metal components such as metal rivets, buttons, zip fasteners, etc.</p> <p>The device can heat these metal objects very fast and thus cause serious burns or even ignition of clothes!</p>

! Users of these devices should immediately consult their medical doctor to avoid potential troubles connected with them while handling the device.

3 PERIODIC INSPECTION AND MAINTENANCE

Scheduling device maintenance has to consider the degree and circumstances of device use. Considerate use and preventive maintenance help prevent needless defects and malfunctions. Perform checks as per standards and law in force. Only workers with adequate electrical engineering qualifications may carry out any jobs on the device.

WARNING!!

Any handling of the power supply, including maintenance, requires its disconnection from the power line. To prevent injuries, always disconnect the power cable and wait at least 10 minutes before removing the casing. Discharge the capacitor circuits before any further work.

Periodic maintenance includes cleaning the device every half a year:

1. Disconnect the device plug from the socket and wait at least 10 minutes (the capacitors inside the device will discharge). Then remove the upper device casing.
2. Clean all dirty power electric connections and tighten any loose ones.
3. Clean the internal device parts (coolers in particular) to remove dust and dirt – for example using a soft brush and vacuum cleaner.
4. The upper casing has to be earthed – remember to connect the yellow-and-green earthing wire before screwing it on.
5. After maintenance, carry out safety measurements as per standards in force.

Note: Never use solvents or thinners (e.g., acetone), because they may damage insulation, plastic parts and lettering on the front panel!!

4 STORAGE

The device has to be stored in a clean and dry room. Protect the device from rain and direct sunshine and freeze.

After heating completion, leave the device switched on for 10 more minutes - it will be cooled down by fans until it is cold, then it deactivates the fans. After that, turn it off using the master switch and disconnect it from the power line.

If you disconnect the device immediately, leave it and all the working coils to cool down for at least 15 minutes.

5 WARRANTY PROVISION

1. Unless otherwise specified, the warranty period for devices is set by the manufacturer at 12 months from the date of sale to the buyer . The induction burner is subject to a 6-month warranty period. Consumables such as extenders, coils, etc. are subject to a 3-month warranty period.
2. When making a claim for warranty repair, the warranty certificate has to be shown; it is only valid if it bears the date of sale, serial number, stamp of the shop and the seller's signature, confirming proper demonstration and explanation of the device features.

3. The warranty period will be extended by the time for which the device is in warranty repair. If the repair finds no defects falling under the warranty, the device owner shall pay the costs of the servicing technician's work.
4. The warranty servicing covers defects occurring during the warranty period demonstrably due to flawed design, flawed workmanship or inappropriate material. Such defects will be repaired by the manufacturer free of charge. Complaints shall be made by the user with the device manufacturer; the place of performance is the manufacturer's registered office.
5. The warranty does not cover defects caused by inexpert handling, overloading, use of wrong accessories, or interventions by unauthorised persons, natural wear and tear, or damage during transport. Recognised defects exclude damage occurring due to inadequate care or neglected maintenance, non-adherence to rules specified in the Manual, using the device for purposes for which it is not intended, and overloading the device, albeit temporarily.
6. The warranty expires if the user makes any unpermitted modifications or changes to the device, connects the device wrongly, or has used the device in contravention of technical requirements .
7. The manufacturer is under no circumstances liable for subsequent damage caused by using the device. This warranty does not under any circumstances constitute the manufacturer's liability in excess of the price of the device.
8. Device maintenance and repairs have to use exclusively original parts supplied by the manufacturer in accordance with their respective instructions for use.

6 COMMISSIONING

6.1 UNPACKING AND FIRST START

1. Unpack the device and any accessories supplied and check that they are in good order and the device and the accessories are not damaged. If you find any defects, do not continue !
2. Leave the device to acclimatise for 15 minutes.
3. Remove the sealing ring located under the coolant tank filling hole lid tab. Pull to remove the lid tab and take out the sealing O-ring. Then push the tab, including the foam gasket, back into the tank lid. Keep the O-ring for potential future use if sending the machine via a parcel service.
4. If the focusing head is not attached to the grip by default, screw it on.
5. Fill the device with the coolant supplied with the device via the filling hole.
6. Connect the device to a 230V socket and turn it on using the switch at the back of the device .
7. The cooling circuit venting is activated automatically, and the letters "FIL" flash on the display during this. The coolant level decreases noticeably during the filling .
8. After completion of the venting, turn the device off and add the coolant so that the coolant level is at the upper edge of the gauge at the back of the device (about 1 cm below the top of the tank).
9. Turn on the device and let the venting proceed. If the level does not sink, the device is filled and vented correctly. Repeat the procedure as needed.

6.2 COOLANT REFILLING

Check and refill the coolant before each device starting. Use the original coolant only! **DO NOT USE WATER!** The device has integrated coolant level inspection. In case the coolant runs out, the device stops heating and displays the error message "E##". In that case, refill the coolant in the tank as described above.

7 REPLACEABLE HEATING INDUCTOR EXTENDERS

The DHI0044 induction heater device comes with a basic focusing heating inductor. The other accessories are listed in Chapter Spare and consumption parts.

Correct and safe functioning of the device requires the use of only original heating inductors, extenders, adaptors and other accessories in accordance with their respective instructions for use.

The lifetime of each type of heating inductor and accessory is shown in its instructions for use along with inspection and maintenance frequencies.

7.1 HEATING INDUCTOR EXTENDER REPLACEMENT PROCEDURE

1. Turn off the device using the switch at the back of the device.
2. Make sure the coolant tank is safely closed.
3. Grasp the grip so that it is in a vertical position with the extender facing upwards, at least 20 cm above the power supply unit. Maintain this position through the entire replacement procedure.
4. Unscrew the heating inductor extender by rotating it counterclockwise until it is released.
5. Make sure the threads and contact surfaces of both the grip and the extender are clean and free of signs of corrosion.
6. Mount the new complete extender by freely rotating it clockwise until the outer contact surface of the extender makes permanent contact.
7. Turn on the device and, after an initial venting of the cooling circuit, check the coolant level and add coolant if necessary.
8. Make a visual check of the tightness of the extender-grip connection and any other connections of the new extender. If there is a coolant leak, safe use of the device is no longer possible.
9. Check the conductivity of the connection by briefly activating the device without any heating inductor load.
 - If the device display shows the output power, everything is alright.
 - If it shows „A.Fr“, the contact between the contact surfaces is incorrect. In that case, safe use of the device is no longer possible

8 ABOUT THE DEVICE AND HEATING

8.1 SUPPORTED TECHNOLOGIES

DHCS3 - Heating Control System 2

This Technology has been developed by enabling controlled heating with multiple-pass real-time control of various parameters, which is the heart of the device features. The heating can thus be controlled in various modes, increasing its applicability and versatility.

DIPA - Dynamic Induction Power Adjust

Automatic optimum setting of required power for achieving max. efficiency, speed and long-term heating in dependence on other heating parameters.

ACMS-Automatic Check And Monitor System

Combines features that check and verify device functionality and condition after activation, and a feature that constantly supervises and monitors the heating running and parameters for maximum device safety and reliability.

DFU-Device Firmware Update

Enables updating the firmware.

8.2 HEATING MODES AND THEIR APPLICATION

The heater has available two different heating modes :

1. Field of burner (CF) power mode

In this mode, the induction heater maintains the same intensity of the magnetic field regardless of the coil surrounding conditions. The heater behaves similarly to a gas burner, where the set field intensity matches the flame power. The amount of introduced heat is then easily controlled by moving the burner nearer or further from the material, similarly to flame heating. The advantage is that it is easier to control the introduced heat as needed and, most importantly, it allows finer and sensitive heating, e.g., in car repairs (warming window edges when removing windows, bodywork plates for easier removal of stickers, rubber parts, etc.).

Advantages:

- Power control by moving nearer or further .
- Fine heating.

2. Control power mode (CP)

In this mode, the device tries to deliver and maintain the set amount of introduced heat or energy to the material. The advantage is thus the controlled amount of heat introduced to the material, which combined with timing enables relatively accurate heating to a set temperature, e.g., for repeated pre-heating in production, etc.

The disadvantage of this mode that when moved further from the material, the device significantly increases the power output to maintain the heat delivery level to the material, thus increasing the loss and resulting in a faster device overheating. The efficiency is reduced as well.

Advantages:

- The device automatically maintains the set amount of heat introduced to the material, thus heating the material accurately.

Drawback:

- The disadvantage is the great increase in the induction output when moved away from the material or with inappropriately chosen coil, resulting in high heating load and quick temperature increase, reducing in turn the load factor and rapidly overheating the device.
- The efficiency is reduced.

8.3 CONTROLLED HEATING

Using the heating timer

The device has an integrated heating timer for easy setting of desired heating time, which combined with the controlled power mode enables relatively accurate and repeatable heating with controlled heat introduction, i.e., heating to a set temperature.

9 DEVICE CONTROLS

9.1 DESCRIPTION OF DEVICE COMPONENTS

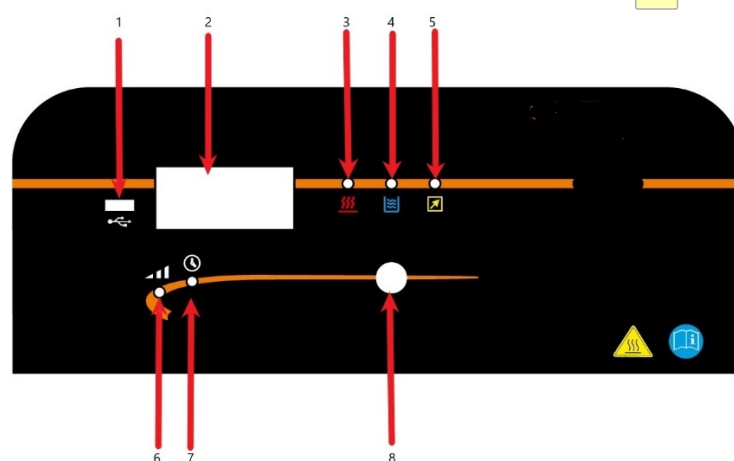

PoS.	Description	Pos.	Description
1	USB connector	5	Indicator REMOTE*
2	Display	6	Control indicator
3	Heating indicator	7	Indicator TIMER
4	Cooling and overheating indicator	8	Encoder*

* The DH10044 is not connectable. The remote control connector is not used in this model series.



Position	Description
1	Coolant reservoir cap
2	Handle
3	Display
4	Induction torch holder
5	Encoder
6	Induction torch cable
7	Handle of induction torch
8	Control cable
9	Button of induction torch
10	Induction focus head



Position	Description
14	Main switch
15	Coolant level indicator
16	Power cord
17	Production label

Heating indicator lamp

- Indicates heating status.



Indicator lamp	Status
	Green
	Yellow
	Red
	Red, flashing

Cooling and overheating indicator lamp



Indicator lamp	Status
	Green
	Green, flashing
	Yellow
	Red

10 ACTIVATING THE DEVICE

- Check the coolant level and refill if necessary.
- Connect the device to a socket and turn it on using the switch at the back of the device.
- The device autodiagnostic test (self-test) is initiated automatically and the cooling circuit is vented; the letters "FIL" flash on the display during this".
- If the device detects lack of coolant, it displays the error message E12:
In that case, refill the coolant in the tank.
- If everything is in order, the device switches to standby.

11 STANDBY

This is the initial device status, which allows turning the encoder to set the desired heating power or temperature, depending on the mode selected:

- Controlled power mode (CP), indicator lamp glows red ● – the user sets the desired heating power in % of maximum heating power and the device automatically adjusts the required parameters to maintain the set power.
- Controlled magnetic field mode (CF), indicator lamp glows green ● – the user sets the desired field intensity in % of maximum field intensity and the device automatically maintains the set field intensity.

The indicator lamp starts flashing during the heating and the display shows the current readings of power output in kW.

The desired heating mode can be set in the settings or switched by pressing and holding down the encoder – the display shows the corresponding mode name CP/CF and the indicator lamp changes colour.

Press the encoder to move to further device parameter settings, such as the heating timer, etc.

Note: If the power is controlled remotely, the letters “rc” are displayed for 3 sec when turning the encoder.

	Indicator lamp	Status
●	Red	Heating power setting in %, mode CP
⚡●	Red, flashing	Power reading in kW during the heating
●	Green	Magnetic field intensity setting in %, mode CF
⚡●	Green, flashing	Power reading in kW during the heating

12 HEATING TIMER

The timer makes it possible to automatically stop heating after a set amount of time, enabling accurate dosing of energy (heat) introduced to the material, e.g., for spot or repeated heating to a set temperature. Press the encoder repeatedly until the ⊕ TIMER indicator lamp glows red ●. Turn to set the desired heating time in seconds or deactivate the timer by selecting “OFF”.

If the timer is set, then the indicator lamp glows green ● when the heating starts, and if the heating is stopped by the timer, the indicator lamp starts flashing green ⚡● and the display shows the letters “OFF” once the button is released. Releasing the button stops the heating immediately.

Note: Press the encoder to enter pre-heating/program settings (see following chapter). To exit to power settings immediately, press and hold down the encoder.

13 LIST OF ERRORS MESSAGES

Error	Description
1	Power supply undervoltage
2	Power supply overvoltage
3	Input overcurrent
4, 5	Output overcurrent
6	Power overload
7, 8	Output frequency out of range
9, 10, 11	Regulation error
12	Out of coolant
13	Hose squeezed or clogged
14 – 18	Device overheating
19	Power supply wrong grid frequency
20-256	Device servicing errors

14 TECHNICAL PARAMETERS

		DHI44E LKW	Unit
Order codes		07-003	
Power requirements	V1	230	V
Frequency	F1	50/60	Hz
Power consumption	I1	16	A
Protection	IP	IP22	-
Working frequency	F2	18-60	kHz
Power control (CP mode)		10-100%, stepless	%
Field control (CF mode)		30-100%, stepless	%
Length of induction torch		2	m
Input power	P1 max	3,5	kW
Output induction power	P2 max	3,7	kVA
Dimensions		240x200x440	Mm
Weight		11,5	Kg
Coolant content		2,5	l

The device is classified for electromagnetic compatibility under the standard ČSN EN 55011 ed.4 : 2017 as a class A, category 2 device.

“Class A device is a device suitable for use in all places except those that belong to residential environments and those that are directly connected to a low-voltage power supply grid supplying power to buildings used for residential purposes.”

“Category 2 devices are devices in which high-frequency energy within the frequency range from 9 kHz to 400 GHz is intentionally produced and used.”

15 ELECTRIC SCHEME

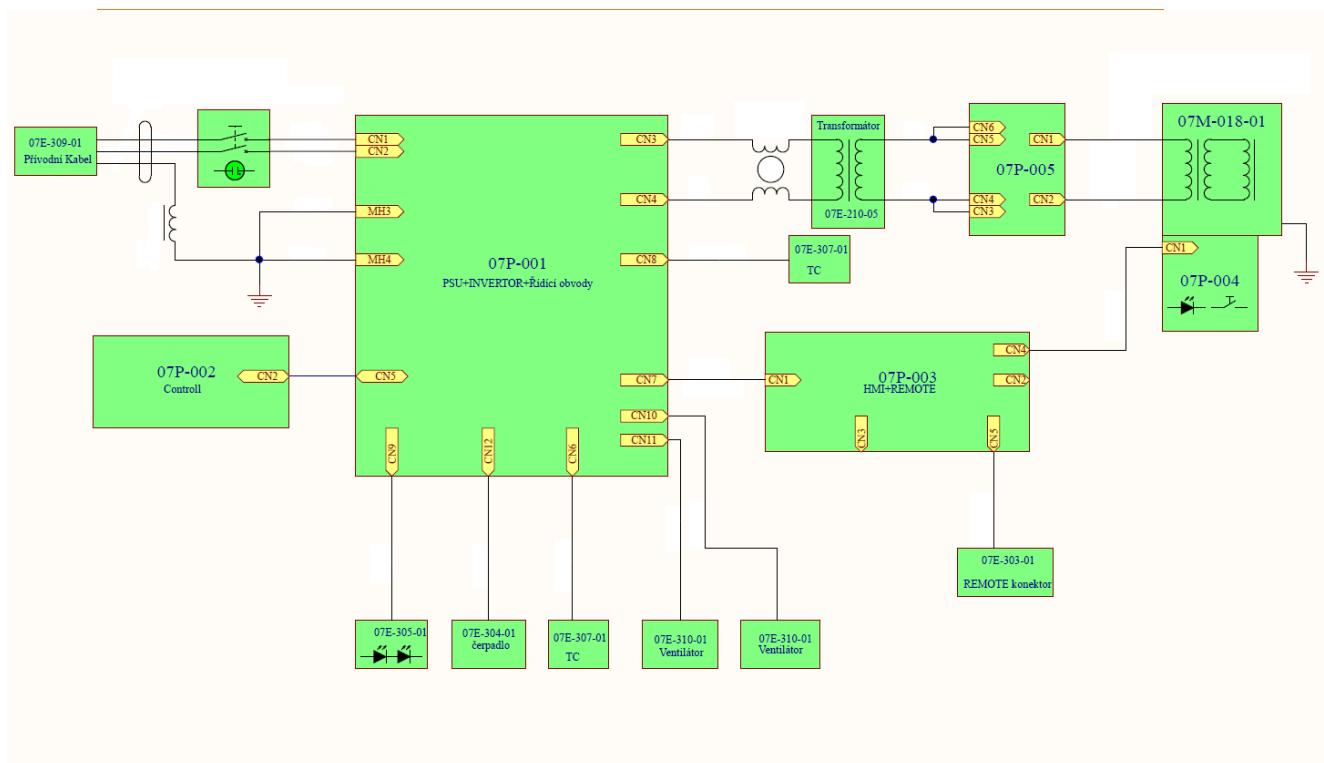

17 SAFETY SHEET OF COOLANT LIQUID

SAFETY SHEET

According to Annex I. Commission Regulation no. 453/2010/EC

Date of preparation: 30.9.2014

Revision date: 26.4.2018

1. IDENTIFICATION OF THE SUBSTANCE	
Product identifier	
Chemical name / synonyms:	
Business name:	MPT 312-6
CAS:	-
EINECS/ELINCS	-
Identified use:	Industrial use: Coolant anti-corrosion fluid Professional use: coolant anti-corrosion fluid
Not recommended use:	-
Emergency telephone number:	02/ 5477 4166 National Toxicology Center

2. HAZARD IDENTIFICATION	
Classification of the mixture according to EP and Council Regulation No 1272/2008 CLP	EUH210
Label elements	
Warning pictogram	-
Warning word	-
Warning	EUH210 A security card can be provided on request.
Safety warnings	-
Other dangers	
Classification of the mixture §45 law no. 67/2010	-
Label elements	
Warning pictogram	-
Warning	-
Safety warnings	-
	The Safety Data Sheet is available to a professional user on Request.
Other dangers	-

3. COMPOSITION / INFORMATION ON INGREDIENTS
A mixture of non-hazardous substances or the content of hazardous substances in this mixture is below the reported concentration.

4. FIRST AID		
Description of first aid measures	Inhalation	Unlikely - it does not evaporate
	Eyes	Thoroughly rinse open caps with water flow for 10 - 15 min.
	Skin	Wash skin as soon as possible with water. Treating with cream. Contaminated clothing should be undone.
	Ingestion	Do not call back. Consult a physician. Ensure quietness and peace of mind.
The most important symptoms and effects, acute and later	There is no inhalation in the usual way of using and maintaining basic hygiene regulations. In case of contact with the skin, it may cause slight irritation. When eye contact is irritating to eyes. If swallowed, it may irritate the digestive tract, May cause nausea and vomiting.	
Need immediate medical assistance	Symptomatic treatment.	

5. FIRE-FIGHTING MEASURES		
Extinguishing media	appropriate	CO ₂ , powder, foam, water
	inappropriately	unspecified
Threats from a mixture or a substance	Burning can produce toxic gases (carbon oxides and nitrogen oxides).	
Advice for firefighters	Protective clothing, self-contained breathing apparatus.	

6. ACCIDENTAL RELEASE MEASURES		
Personal precautions, protective equipment and emergency procedures		
Appropriate technical security	Rinse thoroughly out of leakage.	
Individual protection measures, personal protective equipment	Avoid contact with skin and eye contact. In confined spaces, ensure adequate ventilation before disposal. In case of disposal, suitable eye and skin protection should be used.	
Thermal hazard	None.	
Environmental precautions	Prevent leakage of large quantities of concentrated product into sewage / WWTP (slightly alkaline product).	
Methods and materials to prevent spread and cleaning	Drain the leaky liquid, collect the residue with absorbent materials and deliver it in a closed container for disposal.	
Link to other sections	Disposal: Item 13 Personal protective equipment: item 8	

7. USE AND STORAGE	
Safety precautions for safe use	Protect your eyes from injury. Before work breaks or at the end of working hours thoroughly wash hands with water and treat with a suitable cream. Do not eat, drink or smoke while using.
Conditions for safe storage, including incompatibility	Store in well-closed and original containers in a dry place. Do not store together with acids and oxidizing agents. Shelf life up to 24 months. Unsuitable packaging material: metal Suitable packaging material: Plastic HDPE - 2, PET - 1, PP - 5 packaging
End use specification	Cooling anti-corrosive liquid, -20 ° C

8. EXPOSURE CONTROLS / PERSONAL PROTECTION					
Control parameters	Identification number	Chemical name of the substance	NPEL (mg/m ³)		Note:
			average	short	
	CAS:102-71-6 ES: 203-049-8	2,2', 2'' - nitrilotriethanol	NPK-P	10 mg/m ³ *	* The content of this substance in the preparation is 0,1%
DNEL PNEC	No information available, no risk assessment performed.				
Exposure controls	Occupational exposure controls: a complete set of specific protective and precautionary measures. point 7 of the safety data sheet. Usual precautions are taken when handling chemicals. Do not eat, drink or smoke at work. During breaks and after work, thoroughly wash hands with water. Do not touch your eyes before washing your hands. * The content of this substance in the preparation is below 0.1% Respiratory protection: - Hand protection: Protective PVC impermeable gloves (EN 374) Eye protection: protective goggles EN 166 Skin protection: Protective work clothing (EN 369) Personal and occupational hygiene: Wash contaminated hands with water and soap before work breaks. Do not eat, drink or smoke at work.				

9. PHYSICAL AND CHEMICAL PROPERTIES	
9.1 Information on basic physical and chemical properties	
Physical condition	liquid
Color	clear, or as required by the customer
Odor	characteristic
Odor threshold	not set
pH	8,5
Heat / freezing temperature [°C]	- 20
Initial boiling point and distillation value [°C]	not set
Flash point [°C]	not set
Evaporation rate	not set
Combustibility	non-flammable
Auto-ignition temperature [°C]	not set
Decomposition temperature [°C]	> 300
Explosive properties	non-explosive
Lower explosive limit	not set
Upper explosion limit	not set
Oxidative properties	not set
Vapor pressure	-
Density of hair	not set
Relative density [g.cm ⁻³]	1,04(20°C)
Solubility in water [g.l ⁻¹]	soluble
Solubility in solvents [g.l ⁻¹]	not set
Partition coefficient n-okt./water	not set
Viscosity	not set
9.2 Other information	-

10. STABILITY AND REACTIVITY	
Reactivity	Data not available
Chemical stability	Stable under recommended usage and storage conditions. Reaction with metals - passive
Possibility of dangerous reactions	Data not available
Conditions to be avoided	Contact with unsaturated compounds - loss of corrosion properties
Incompatible materials	Data not available
Hazardous decomposition products	Upon thermal decomposition, amines are formed.

11. TOXICOLOGICAL INFORMATION		
Propán-1,2-diol according ECHA is not classified as dangerous		
Acute toxicity LD ₅₀	Při požití	< 8000 mg/kg
	Při zasažení pokožky	> 8000 mg/kg
	Při vdechnutí potkan	< 5000mg/kg
Chronic toxicity	Data not available	
Corrosive properties	Data not available	
Irritability	Eyes	Irritating to eyes
	Skin	Data not available
	Inhalation	Data not available
Sensitive properties	Skin	It is not expected
	Inhalation	Data not available
Mutagenicity	It is not expected	
Reproductive toxicity	It is not expected	
Carcinogenicity	It is not expected	
Aspiration toxicity	Data not available	

12. ECOLOGICAL INFORMATION

Toxicity to aquatic organisms	Data for the mixture is not known
Persistence and degradability	Degradable under EU Directive No. 648/2004.
Bioaccumulative potential	Data for the mixture is not known
Mobility in soil	Data for the mixture is not known
Results of PBT and vPvB assessment	The mixture does not contain Substances classified as PBT vPvB at the date of preparation of the SDS.
Other adverse effects	-

13. DISPOSAL CONSIDERATIONS

Waste treatment methods	<p>Waste and contaminated absorbent materials should be disposed of as hazardous waste in accordance with Act No. 223/2001 on waste in an authorized facility.</p> <p>Do not dispose of together with municipal waste. Clean up the liquid in WWTP!</p> <p>Classification according to the Waste Catalog: 10 02 99</p> <p>After thorough rinsing, the packaging can be disposed of in a separate collection.</p>
--------------------------------	------------------------------------------------------------------------------------------------------------------------------------------------------------------------------------------------------------------------------------------------------------------------------------------------------------------------------------------------------------------------------------------------------------------

14. TRANSPORT INFORMATION

Number OSN	It is not dangerous in terms of transport regulations.
Proper shipping name OSN	-
Transport hazard class	-
Packaging group	-
Dangers to the environment	-
Personal precautions of the user	-
Bulk cargo transport	-

15. REGULATORY INFORMATION

Safety, health and environmental regulations / legislation specific for the substance or mixture
<p>Regulation (EC) No 1907/2006 of the European Parliament and of the Council on the Registration, Evaluation, Authorization and Restriction of Chemicals (REACH) and on the establishment of a European Chemicals Agency, amending certain Directives Commission Regulation No 453/2010 amending and supplementing Regulation EP and Council Regulation 1907/2006 REACH</p> <p>Regulation of the European Parliament and of the Council No. 1272/2008 on Classification, Labeling and Packaging of Substances and Mixtures Act of the National Council of the Slovak Republic No. 67/2010 on the placing of chemical substances and mixtures on the market</p> <p>Decree No. 3/2010 on the implementation of Act No. 67/2010 on the placing of chemical substances and mixtures on the market Government Order No. 355/2006 on the protection of workers from the risks related to exposure to chemical agents at work as amended by Regulation Government of the Slovak Republic no. 471/2011</p> <p>Restrictions according to Regulation 552/2009 (Annex XVII of Regulation EP and Council No. 1907 / 2006REACH): none</p> <p>Substances included in the Candidate List (SVHC) pursuant to Regulation (EC) No 1907/2006 of the European Parliament and of the Council REACH: none</p>

16. OTHER INFORMATION

Reason for Revision: - H-phrases not elsewhere specified.
Packaging measures when placed on the retail network: none

18 USED DEVICE DISPOSAL



These devices are built using materials that contain no toxic substances or poisonous to the user. Dispose of the discarded device using a collection point intended for collection of used electric equipment. Do not dispose of the used device as ordinary waste.



The company is registered in the ASEKOL collective system (under manufacturer registration no. 04499/16-ECZ) and finances handling of electrical waste itself. This symbol on products and/or in accompanying documentation means that used electrical and electronic products must not be added to ordinary municipal waste.

19 SPARE AND CONSUMPTION PARTS

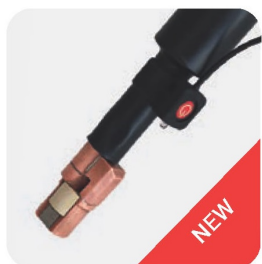

Coil „Car Nut“
BIH0108



Focus coil, side
BIH0103



Focus coil, inclined
BIH0102



Trolley
BIH0400



Handle extension
BIH0101



Round focus coil
BIH0110
And round coil
reducer BIH0105



Focus coil, straight
BIH0104

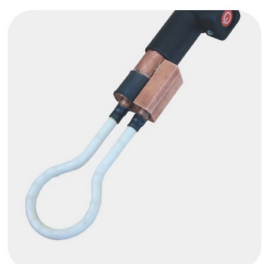

Coil 26 mm
BIH0002

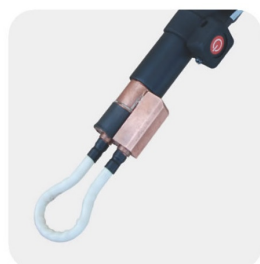

Coil 20 mm
BIH0001

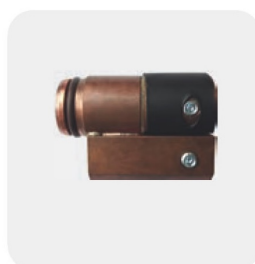

Reducer
BIH1105



Coolant liquid
3 l BIH1003
10 l BIH1010

20 QUALITY CERTIFICATE

Importer: JHM BUTT & CO LTD UK

Type of product: DHI0044

Seriál number:

Date of final inspection:

Inspected by:

21 WARRANTY SERVICING

-
1. Warranty service may only be performed by a service technician trained and authorized by the manufacturer.
 2. Before performing warranty repairs must check the data on the machine: date of purchase, serial number, machine type. If the information is not in accordance with the conditions for the recognition of warranty repairs, for example. Condition warranty, improper use of the product contrary to instructions for use etc., it is not a warranty repair. In this case, all costs associated with repair are paid by the customer.
 3. In the case of repeating the same error in one machine and the same work, it is necessary to consult the manufacturer's service technician.

