

Block saw

BS 650

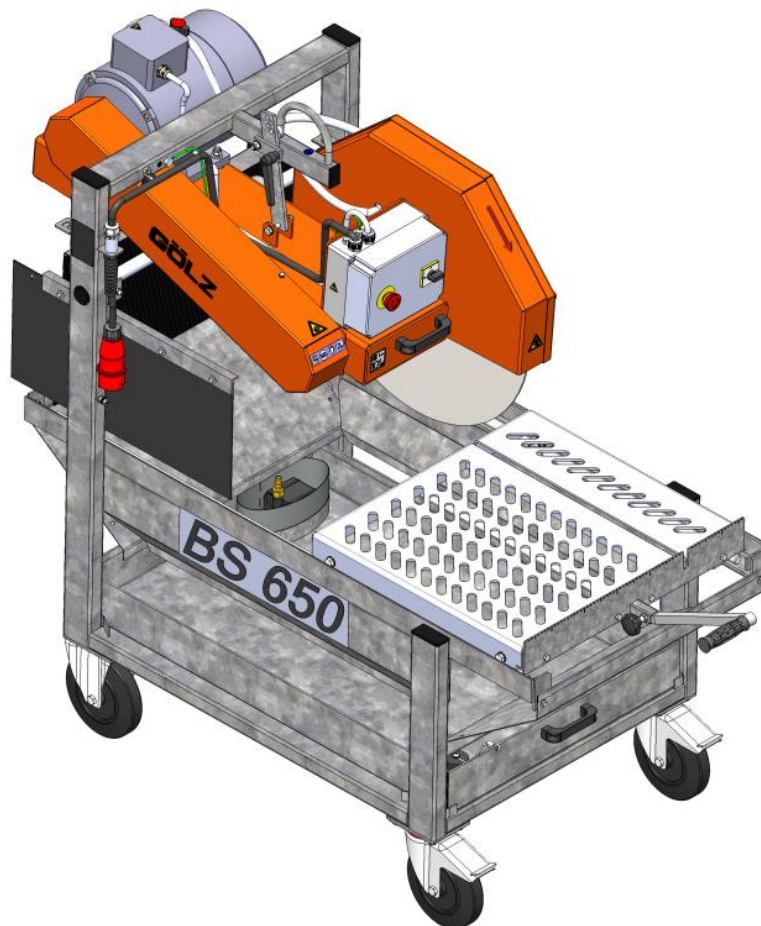

ZN der Bedienungsanleitung:

5009011-03

Erstellt am:

10/2022

Erstellt von:

Konstruktion

Datei:

K:\KDV\5009xxx\5009011-Bedienungsanleitung-BS650\
5009011-03-Bedienungsanleitung-GB.doc

GÖLZ® GmbH

Dommersbach 51

D-53940 Hellenthal

Telefon: +49 (0) 2482 12 200 / Telefax: +49 (0) 2482 12 222

E-Mail: info@goelz.de / Internet: www.goelz.de

All rights reserved according to DIN ISO 16016.

No part of this document (instruction manual and spare parts list) may be reproduced, adapted, transmitted, transcribed, stored on a data medium or be translated into another language without prior written approval of

GÖLZ® GmbH
Dommersbach 51
D-53940 Hellenthal

Guarantee

We reserve the right to amend any information included in this document (manual instruction and spare parts list) at any time and without prior notice.

GÖLZ® assumes no warranty for these documents.

GÖLZ® shall not be liable for errors in this document (manual instruction and spare parts list) or for any collateral or consequential damage in connection with shipment, performance or use of the material.

**EC-Declaration of conformity****GÖLZ® GmbH**

Dommersbach 51
D-53940 Hellenthal
Deutschland

declare in exclusive responsibility that the product

Category: Block saw
Make: GÖLZ
Typ: BS650

conforms to the relevant provisions of Directives

2006/42/EG

Machinery directive

2014/30/EU

Electromagnetic compatibility

2005/88/EG

Noise emission

and has been developed and manufactured in compliance with the following standards in the versions valid on the date of production:

DIN EN ISO 12100:2011-03

DIN EN 60204-1; VDE 0113-1:2007-06

EN 12418:2000

EN 13309:2000

EN 61000

The measured and guaranteed sound power levels were determined according to Directive 2005/88/EG.

Measured sound power level

BS650: No load = 80,6 dB(A)
Full load = 98,8 db(A)

Technical documents deposited at:

GÖLZ® GmbH

Entwicklung & Konstruktion

The year of manufacture and serial number are applied to the product.

Hellenthal, 16.05.2019

GÖLZ® GmbH

General Manager
Bernd Schmitz

Contents

Preface	6
Warning signs and symbols.....	6
1. Machine description	7
1.1 Intended use-description	7
1.2 Main parts	7
1.3 Technical data.....	8
1.4 Shipment and provided accessory.....	9
1.5 Optional accessory.....	9
1.6 Operating elements.....	9
1.7 Safety devices.....	10
2. Basic safety instructions.....	10
2.1 Intended use	10
2.2 Operating range	11
2.3 Organisational measures	11
2.4 Selection and qualification of person.....	12
2.5 Safety instructions governing specific operational phases.....	12
2.6 Special work related to the maintenance and repair of the machine	13
2.7 Information about special risks with electrical energy	14
2.8 Gas, dust, steam, smoke.....	15
2.9 Noise.....	15
2.10 Illumination.....	15
2.11 Oils, greases and other chemical substances.....	15
2.12 Transport.....	15
2.12.1 Preparation	16
2.12.2 Transporting.....	17
2.13 Store	17
3. Preparing for Operation.....	17
3.1 Export checking.....	17
3.2 Installation.....	18
3.3 Blade.....	18
3.3.1 Mounting the blade	19
3.4 Water supply	19
3.5 Mounting / dismounting fork lift guide	20
4. Operation	21
4.1 Before starting the machine.....	21
4.2 Cutting operation.....	22
4.3 Stop cutting operation	23
4.4 Changing the blade	23

5. Maintenance	24
5.1 General	24
5.2 Water pump und water tank	26
5.3 Motor	26
5.4 Lubricating chart	26
5.5 V-belt	26
5.6 Cutting table	27
5.7 Machine	27
5.8 Blade	28
6. Taper bushes installation instructions	28
6.1 To assemble	28
6.2 Removal	28
7. Troubleshooting	29
8. Spare parts list	33
8.1 Using the spare parts list	33
8.1.1 Safety regulation	33
8.1.2 Ordering information	33
8.1.3 Distribution agencies	34
8.2 Wearing parts	35
9. Exploded view and spare parts list	37
9.1 Frame	37
9.2 Cutting head	41
9.3 Cutting table	47
10. Optional accessory	49
10.1 Forklift guidance	49
10.2 Back square	50
11. Connection diagram	51

Preface

Thanks for choosing a **GÖLZ®**-product. This operating instruction is designed to familiarize the user with the machine and its designated use.

The operating instruction contains important information on how to operate the machine safely, properly and most efficiently. Observing these instructions helps to avoid danger, to reduce repair costs and downtimes and to increase the reliability and life of the machine. The operating instruction is to be supplemented by the respective national rules and regulations for accident prevention and environmental protection. The operating instruction must always be available wherever the machine is in use. This operating instruction must be read and applied by any person in charge of work with or on the machine, such as:

- Operation including setting up, troubleshooting in the course of work, evacuation care and disposal of fuels and consumables.
- Maintenance (servicing, inspection, repair) and/or
- Transport

In addition to the operating instructions and to the mandatory rules and regulations for accident prevention and environment protection of the country and place of use of the machine, the generally recognized technical rules for safe and proper working conditions and procedures must also be observed.

In this manual all the information required for the intended use of the unit is included. If though you have any specific questions, please refer to your representative, to one of our sales representatives or directly to us:

GÖLZ® GmbH

Dommersbach 51, D-53940 Hellenthal

Telefon: +49 (0) 2482 12 200 / Telefax: +49 (0) 2482 12 222

E-Mail: info@goelz.de / Internet: www.goelz.de

Warning signs and symbols



Wear safety glasses!



Wear ear muffs!



Wear hard hat!



Wear dust protection!



Wear safety boots!



Read owner's manual before first initiation!



Wear protective gloves!



Wear safety clothes!



Never touch!



Important advice!



General danger!



Danger exists to cut oneself!



Electrical Hazard!

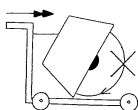

It is not allowed to move the machine with rotating blade outside of the area in which cutting works have to be performed!

1. Machine description

1.1 Intended use-description

The BS 650 is a powerful and robust block saw. Its operation range includes wet separating/wet cutting of voluminous block stones such as cellular bricks, pumice stone, sand-lime bricks, gas concrete or similar abrasive building material.



Attention: In no case is the BS 650 suitable for the cutting of metal or wood.

The BS 650 facilitates the swift and precise wet separating/wet cutting in your business or on the construction site. The machine can be equipped with a blade diameter of max. 650 mm. The cooling water is carried by an electric water pump. Thanks to the adjustable cut depth, the cutting head can be positioned at various heights by swiftly and simply loosening and tightening the clamp lever. The removable water basin facilitates and simplifies the cleaning.

1.2 Main parts

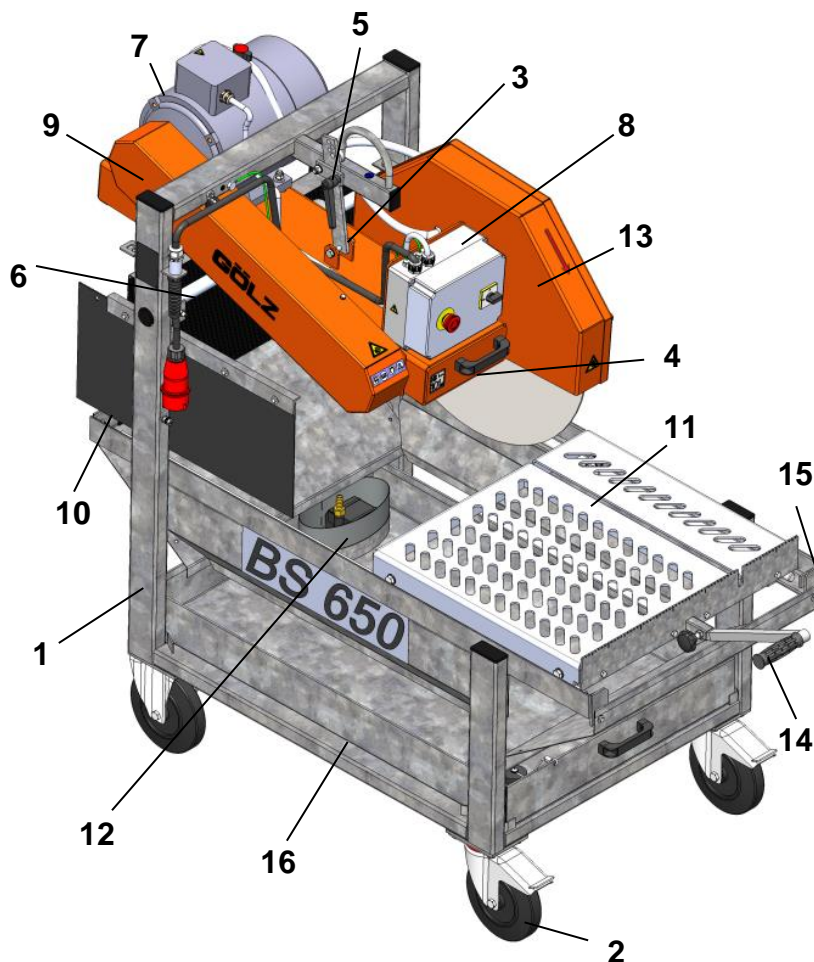

1. Frame
2. Transport wheels
3. Cutting depth control
4. Cutting head
5. Clamp lever
6. Pendulum shaft
7. 3-phase electric motor
8. Switch box
9. V-belt guard
10. Splash guard
11. Cutting table
12. Electric water pump
13. Blade guard
14. Push rod
15. Fail safes cutting table
16. Water tank

The galvanised and torsion resistant frame (1) is provided with a central crane eyelet and forms the basis of the block saw. Furthermore, the steel frame prevents vibrations during the cutting process and thus increases the cutting disc output.

The block saw is supported by four transport wheels (2). The machine can thus easily be moved to the operation site. Two transport wheels are designed as lockable casters.

The cutting depth adjustment (3) is linked to a pivoted cutting head (4) which is articulated on a pendulum shaft and can be loosened or tightened with a clamp lever (5).

The block saw is powered by a 5,5 kW three-phase motor (7), protection category IP55.

The switch box (8) is equipped with an overload protection, undervoltage release, star-delta switch and emergency stop. The restart lock prevents the machine from starting after a power failure.

The V-belt drive is enclosed in a guard (9). This minimizes the risk of injuries by the drive and protects the V-belt drive from pollution during the cutting procedure.

Splash guards (10) arranged at 3 sides offers an optimal protection against splash water during machine operation.

The workpiece is moved forward and backward by a user-friendly push rod (14) on the ball bearing mounted cutting table (11) or separated in full cut when the cutting head is locked. The transport lock (15) prevents the cutting table from unintentional rolling to and fro.

The cutting blade guard (13) offers optimal protection for the operator and all persons within the work area during the cutting procedure. The swivelling guard allows an easy and simple mounting of the cutting blade.

To prevent dust formation when cutting and to cool the cutting blade, the BS 650 is equipped with an electrical water pump (12) which is protected by a pump box against coarse impurities.

The machined material accruing during the separation/cutting procedure is collected in the slide-out water basin (16).

1.3 Technical data

Max. cutting depth	260 mm - 10.24 in.
Cutting length	500 mm - 19.69 in.
Cutting table (L x W)	610 x 670 mm - 24.02 x 26.38 in.
Max. blade-Ø	650 mm - 25.6 in.
Arbor hole	Ø 60 mm - 2.36 in.
Flange size	Ø 120 mm - 4.72 in.
Motor	3-phase motor 400 V, 50 Hz, 32 A, IP 54, 1445 rpm, 5,5 kW (7,5 HP) Current consumption 11 A, Protective motor switch and low-voltage protection
Blade shaft speed	1040 rpm
Max. cutting speed with cutting disc Ø 650 mm	35,4 m/s
Feed	Roller cutting table/manual feed
Water supply	Electric water pump, set for 230V

Dimensions (L x W x H)	ca. 1600 x 800 x 1200 mm - 63 x 31.5 x 47.24 in.
Weight	ca. 230 kg - 506 lbs.
Service weight	ca. 300 kg - 660 lbs. (filled water tub and mounted blade Ø 650 mm - 25.6 in.)
Sound power level pursuant to EN ISO 3744, DIN EN 11201	No load = 80,6 dB(A) Full load = 98,8 dB(A)

1.4 Shipment and provided accessory

- Block saw BS 650
- Operating instruction and spare parts list block saw
- Tool for blade mounting
- Push rod for cutting table

1.5 Optional accessory

- Transport guide fork lift truck
- Angular stop
- Replacement water pump

For the item number of accessories, please refer to the current catalogue of **GÖLZ®**
 If accessories are used which do not correspond to **GÖLZ®** specifications, no liability is assumed for any damage resulting hereof.
 For details regarding the selection of the right **GÖLZ®** diamond blades, please refer to the current **GÖLZ®** catalogue for diamond tools.

1.6 Operating elements

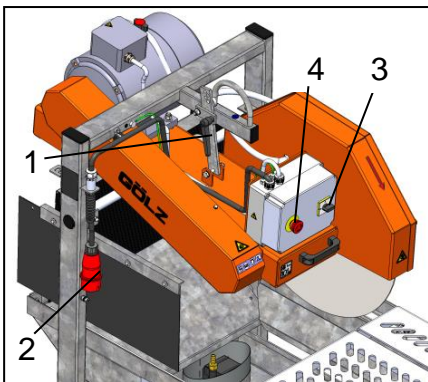

1. Cutting depth control
2. Main plug/ Main switch
3. Star-delta starting switch
4. Emergency stopping

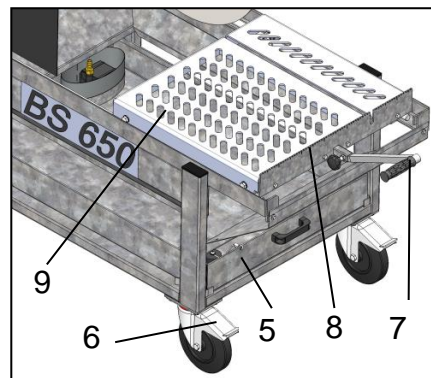

5. Water tank
6. Fixed roller for heavy loads
7. Push rod
8. Stop bar
9. Cutting table

1.7 Safety devices



Danger: During cutting, all safety devices shown below must be mounted!

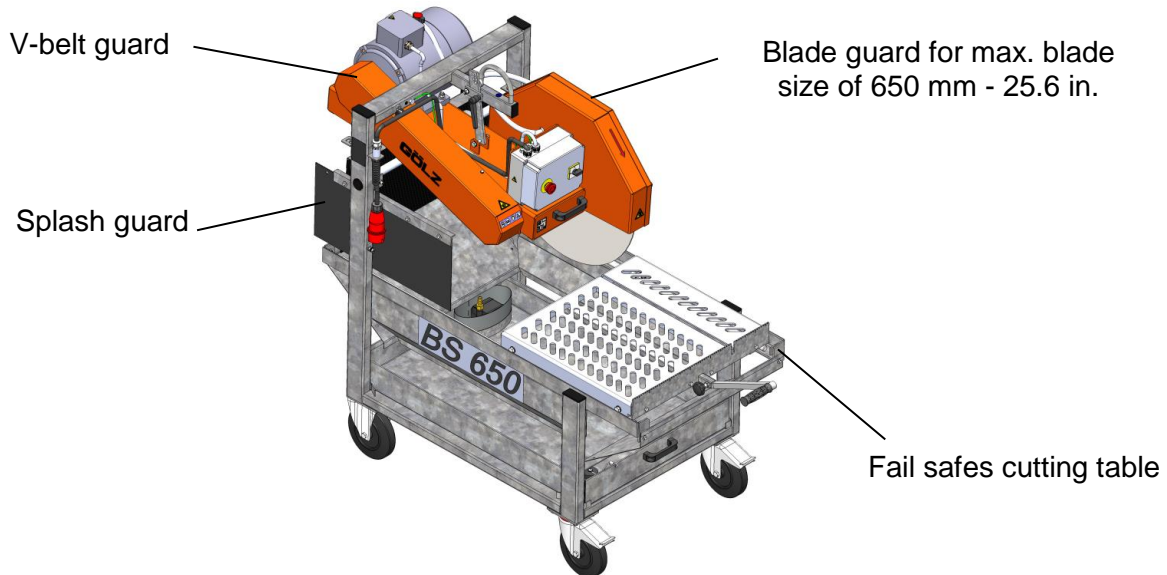

2. Basic safety instructions

In this manual the following terms and symbols are used for particular important information:



Note / Important: Contains important information which stands out from the other text!



Attention: Contains instructions which must be strictly observed to prevent damage from the unit and the operator!

Important text passages are highlighted in italics or bold or can be found in a grey highlighted text field.

2.1 Intended use

- The machine has been constructed according to the state of art and the recognized safety-related rules. Nevertheless, its use can entail dangers to body and soul of the user or third parties or damage the product and other material assets.
- Only use the machine in perfect technical state, according to the intended use, safety- and risk-conscious, with due regard to the operating instructions! Immediately remedy or have remedied defects which can impair the safety!
- The machine is exclusively designed for cutting voluminous block stones such as cellular bricks, pumice stone, sand-lime bricks, gas concrete and concrete. Any other or wider use such as cutting wood is not compatible with the intended use. The manufacturer shall not be liable for damage resulting from such use. The user alone supports the risk.



Attention: In no case is the BS 650 suitable for the cutting of metal or wood.

- Usage according to the intended conditions of use also includes observing the operating instructions as well as following the inspection and maintenance instructions.



Attention: Read and observe all the operating instructions which belong to this unit!

- Never work in an explosive surrounding, next to explosive material or in unventilated rooms.

2.2 Operating range

Do not modify, add components to or retrofit the unit in a way which could affect its safety and do not use non-official accessories! This is not allowed without prior approval of **GÖLZ® GmbH!**

2.3 Organisational measures

- This operating manual must always be at hand at the place of use of the machine and must be accessible to the person operating the machine!
- In addition to this operating manual, all other generally applicable legal and other mandatory regulations relevant to accident prevention and environmental protection must be observed! Such obligations may also comprise the handling of hazardous materials, provisioning and/ or wearing of personal protective equipment, or road traffic regulations.
- This operating manual must be supplemented by instructions covering the duties involved in supervising and notifying special organizational features, such as job organization, work flows or the person entrusted with the work.
- Person entrusted with work on the machine must have read the operating manual prior to taking up work. This applies especially to persons working only occasionally on the machine, e.g. during set-up or maintenance activities.
- Check - at least from time to time - whether the personnel is carrying out the work in compliance with the operating manual and paying attention to risks and safety-relevant factors.
- For reasons of safety, long hair must be tied back or otherwise secured, garments must be close-fitting and no jewellery - including rings - may be worn.
- Severe injury may result from being caught by moving parts of the machine. Personal protective equipment must be used wherever required by the circumstances or by law (e.g. safety glasses, ear protectors, safety boots, suitable safety clothing).

The personal protection equipment should consist of the following parts:

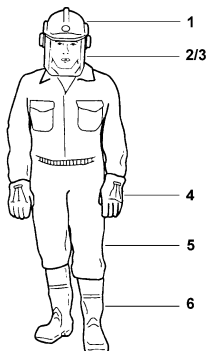

- | | | |
|-----|-------|-------------------------------------|
| 1 | 1 | Hard hat with ear muff |
| 2/3 | 2 / 3 | Visor or safety glasses / Dust mask |
| 4 | 4 | Protective gloves |
| 5 | 5 | Safety clothes |
| 6 | 6 | Safety boots |



- Observe the regulations for prevention of accidents! Observe all safety precautions and warnings attached to the machine and always keep them in good and perfectly legible condition.
- In case event of safety-relevant modifications or changes in the behaviour of the machine, stop the machine immediately and report the malfunction to the competent authority/ person. Do not remove or make inoperative any safety devices the machine is equipped with.
- Never make any modifications, additions or conversions which might affect safety without **GÖLZ® GmbH** prior approval! This also applies to the installation and adjustment of safety devices as well as to welding and cutting work on supporting structures.
- Damaged or worn parts of the product must be replaced immediately. Use genuine spare parts only. All spare parts and tools must comply with the technical requirements specified by the manufacturer/ distributor.
- Adhere to the legally prescribed preventive maintenance and inspection intervals or those specified in this operating manual!
- Hydraulic hose pipes must be changed within the specified or appropriate intervals, even if no safety-relevant defects are visible.
- All maintenance and repair activities must be performed by qualified personnel using suitable tools and other suitable workshop equipment.
- Observe the fire alarm and fire protection measures. The personnel must be made familiar with the location and handling of fire extinguishers!!

2.4 Selection and qualification of person

- Only permitted personnel are allowed to work on and with the machine! The legal minimum age is to be observed!
- Only assign trained and instructed personnel! Clearly define the responsibilities of the personnel with regard to operating, setting-up, maintaining and repairing the machine! The **GÖLZ® GmbH** can assist you in training your personnel.
- Make sure that only instructed and competent personnel work on the machine.
- Define the responsibility of the machine operator, also in terms of traffic regulations and enable him to refuse instructions of third parties which breach safety regulations.
- Personnel that is to be trained or to be instructed or that is serving a general training is only to be permitted to operate the machine under the supervision of an experienced person.
- To operate the machine you must be rested, in good physical condition and mental health. If you have any condition that might be aggravated by strenuous work, check with your doctor before operating with the machine. Do not operate the machine if you are under the influence of any substance (drugs, alcohol) which might impair vision, dexterity or judgment.
- Works on electrical, pneumatic, combustion and hydraulic fittings and equipment are only to be carried out by qualified personnel or instructed people being directed and supervised by qualified personnel in compliance with the respective rules!

2.5 Safety instructions governing specific operational phases

Before work

- Avoid any operational mode that might be prejudicial to safety!
- Before beginning work, familiarize yourself with the surroundings and circumstances of the site, such as obstacles in the working and travelling area, the soil bearing capacity and any barriers separating the construction site from public roads.
- Take the necessary precautions to ensure that the machine is used only when in a safe and reliable state.

- Operate the machine only if all protective and safety-oriented devices, such as removable safety devices, emergency shut-off equipment, sound-proofing elements and exhausters, are in place and fully functional. Regard all safety specifications!
- Check the machine at least once per working shift for obvious damage and defects. Report any changes (incl. changes in the machine's working behaviour) to the competent organization/ person immediately. If necessary, stop the machine immediately and lock it.
- Have any defects rectified immediately. At any time, ensure the operator has sufficient view to his working area, in order to have intervention to the working process.
- Wet cutting is to be accomplished while working. This prevents the appearance of particulate matter and increases the life-time of the diamond tool.
- During start-up and shut-down procedures always watch the indicators in accordance with the operating instructions!
- Before starting or setting the machine in motion, make sure that nobody is at risk. Keep children and unauthorized persons away from the work area.
- Noise protection equipment on the unit must be in protective position during operation. Wear the required individual ear protection!
- Always keep at a distance from the edges of building pits and slopes. Avoid any operation that might be a risk to machine stability!
- Keep the work area clean. Cluttered areas and benches invite injuries! Do not operate when you are tired!
- Watch what you are doing! Risk of stumbling! Cables and hoses must complete rolling up. After assembly do not leave any tools, a wrench for example, on the unit.
- Check to see that the tools are removed from the machine before operating! Damaged blades have to be changed immediately. Use only recommended blades from the **GÖLZ® GmbH**.
- Control the working area for water-, gas- and electrical lines!



Important: Wet cutting is to be accomplished while working! This prevents the appearance of particulate matter and increases the life-time of the diamond tool!

During work

Make sure, that the machine is well fastened before and while cutting!
Never touch rotating parts like blade shaft or blade!

After work

Before leaving the machine always secure it against unauthorized use!

2.6 Special work related to the maintenance and repair of the machine

- Observe the adjustment, maintenance and inspection activities and intervals set out in the operating instructions, including information on the replacement of parts and equipment! These activities may be executed by skilled personnel only.
- Brief operating personnel before beginning special operations or maintenance work, and appoint a person to supervise the activities.
- In any work concerning the operation, conversion or adjustment of the machine and its safety-oriented devices or any work related to maintenance, inspection and repair, always observe the start-up and shut-down procedures described in the operating instructions and the information on maintenance work. Ensure that the maintenance area is adequately secured.
- Carry out maintenance and repair work only if the machine is positioned on stable and level ground and has been secured against inadvertent movement and buckling. If the machine is completely shut down for maintenance and repair work, it must be secured against inadvertent starting.
- To avoid the risk of accidents, individual parts and large assemblies being moved for replacement purposes should be carefully attached to lifting tackle and secured. Use only suitable and technically perfect lifting gear and suspension systems with adequate lifting capacity. Never work or stand under suspended loads.
- The fastening of loads and the instructing of crane or floor-borne vehicle operators should be entrusted to experienced persons only. The marshaller giving the instructions must be within sight or sound of the operator.

- For carrying out overhead assembly work always use specially designed or otherwise safety-oriented ladders and working platforms. Never use machine parts as a climbing aid. Wear safety harness when carrying out maintenance work at greater heights.
- Clean the machine, especially connections and threaded unions, of any traces of oil, fuel or preservatives before carrying out maintenance / repair. Never use aggressive detergents. Use lint-free cleaning rags.
- Before cleaning the machine with water, steam jet or detergents, cover or tape up all openings which -for safety and functional reasons - must be protected against water, steam or detergent penetration.
- Do not clean the machine with a high-pressure cleaner. The hard water jet can put damage to parts of the machine. After cleaning, remove all covers and tapes applied for that purpose.
- After cleaning check the machine for loose connections, chafe marks and damage! Have identified defects repaired immediately!
- Always tighten any screwed connections that have been loosened during maintenance and repair.
- Any safety devices removed for set-up, maintenance or repair purposes must be refitted and checked immediately upon completion of the maintenance and repair work. Ensure that all consumables and replaced parts are disposed of safely and with minimum environmental impact.

2.7 Information about special risks with electrical energy

- Observe the relevant national regulations or standards. Electrical connections must always be kept free from dirt and moisture.
- Use only original fuses with the specified rating! Switch off the machine immediately, if trouble occurs in the electric power supply!
- If your machine comes into contact with a live wire:
 - warn others against approaching and touching the machine
 - have the live wire de-energized
- When working with the machine, maintain a safe distance from overhead electric lines. If work is to be carried out close to overhead lines, the working equipment must be kept well away from them. **Caution, danger to life!** Check out the prescribed safety distances.
- Work on the electrical system or equipment may only be carried out by a skilled electrician himself or by specially instructed personnel under the control and supervision of such electrician and in accordance with the applicable engineering rules.
- If provided for in the regulations, the power supply to parts of machines and plants, on which inspection, maintenance and repair work is to be carried out must be cut off.
- Before starting work, check the de-energized parts for the presence of power and ground or short-circuit them in addition to insulating adjacent live parts and elements.
- The electrical equipment of machines is to be inspected and checked at regular intervals. Defects such as loose connections or scorched cables must be rectified immediately.
- Necessary work on live parts and elements must be carried out only in the presence of a second person who can cut off the power supply in case of danger by actuating the emergency shut-off or main power switch. Secure the working area with a red-and white safety chain and a warning sign. Use insulated tools only.
- If mobile electrical equipment, connecting cables and/ or extension/ appliance cords with plug connectors are used, ensure that such equipment, cables and cords are checked for correct function at least once every six months by a qualified electrician or - if suitable testing equipment is available - by a properly instructed person.
- Protective installations with fault-current protection units used in non-stationary equipment must be checked for correct operation at least once a month by a properly instructed person.
- Fault-current and fault-voltage protection units must be checked for correct operation by actuating the testing facility:
 - once on every working day in the case of mobile equipment,
 - at least once every six months in the case of stationary equipment.

2.8 Gas, dust, steam, smoke

- Operate combustion engines only in sufficiently ventilated rooms! The exhaust gases contain toxic carbon monoxide.
- Before starting in closed rooms, provide for sufficient ventilation!
- Carry out welding, burning or grinding work only if it is explicitly authorized (possible fire or explosion risk)!
- Prior to welding, burning and grinding remove dust and flammable substances from the machine and the environment and provide sufficient ventilation (explosion risk)!
- When working in narrow rooms observe the existing national rules.

2.9 Noise

- During operation sound protection devices on the machine must be in safe position.
- Wear the prescribed personal ear protection! (UVV 29 § 10, Article 29 of the Accident Prevention regulations).
- The use of noise emitting machines may be restricted to certain times by national or local regulations

2.10 Illumination

The machine is designed for use in daylight! The machine operator / owner must ensure sufficient workplace lighting for non-illuminated work sites!

2.11 Oils, greases and other chemical substances

- When handling hydraulic fluids, lubricants, greases or preservatives (referred to hereinafter as fuels and lubricants), the safety regulations which apply to the respective machine are to be observed!
- Avoid long contact of the fuels and lubricants with your skin! Careful cleaning of the skin from adhering fuels and lubricants is necessary.
- Be careful when handling hot consumables (risk of burning or scalding) particularly at liquid temperatures above 60°C, avoid any skin contact with these liquids!
- If you get fuels or lubricants in your eyes, rinse them immediately and carefully with potable water. Then consult a doctor.
- Remove flown out fuels and lubricants immediately! Therefore use a binder. Fuels and lubricants must not seep into the soil or into the public sewage system!
- Fuels and lubricants which can no longer be used are to be collected, properly stored and to be properly disposed of. The respective regulations and laws for handling fuels and lubricants which are valid in the country of use are to be observed and adhered to. This also applies to the disposal of such fuels and lubricants. To inform yourself turn to the responsible authorities.

2.12 Transport

- Use only suitable means of transport and lifting gear of sufficient capacity when loading or transporting the machine! Appoint an experienced instructor for the lifting operation!
- Always observe the instructions given in the operating manual when lifting the machine (use only the prescribed lifting eyes for attaching the lifting gear)!
- Use only suitable transport vehicles with sufficient load capacity! Secure the load carefully. Use suitable fastening points for securing!

- Before loading the machine or parts of it, secure the machine against inadvertent movement! Attach a suitable warning sign!
- The blade must be removed for transport. Even in case of a minor change of location, the engine must be stopped!
- Before using the machine again, make sure that such protection material or devices are properly removed! Parts which had to be removed for transporting of the machine must be refitted and secured carefully before the machine is used again!
- Before setting the machine in motion always check that all accessories are safely stowed.
- The recommissioning procedure must be strictly in accordance with the operating instruction! Observe the instructions given in the operating instruction when reassembling and operating the machine.

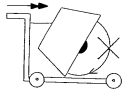
	<p><i>During cuts displace the machine only with non-rotating blade (not running engine)!</i></p>
---	--

	<p><i>Injury hazard: Down coming parts!</i></p>
---	--

	<p><i>Injury hazard: Sharp edges!</i></p>
---	--

2.12.1 Preparation

Before transport disconnect the main plug (1) and dismount the cutting blade. For this loosen the screw (2) of the cutting blade guard and swing the blade guard (4) to the side. Dismount the cutting blade (3) and close the blade guard (4) again.

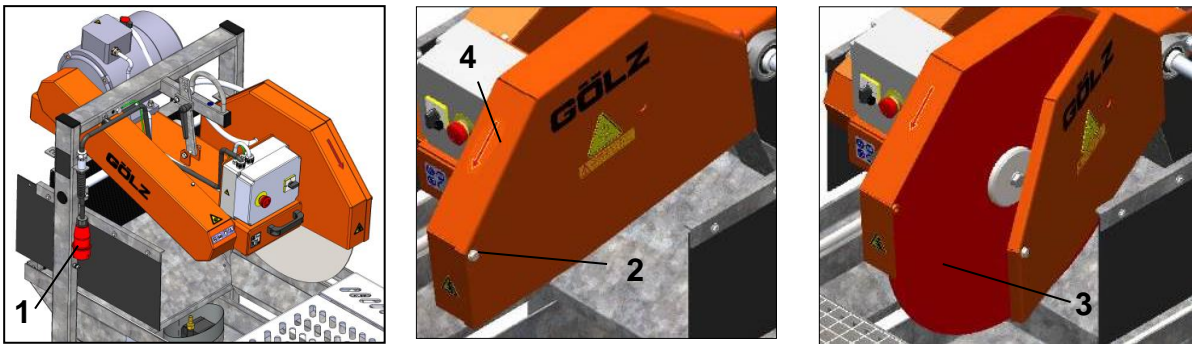

Lock the cutting head (5) with the clamp lever (6). Push the cutting table (7) forward and lift it into the table lock (8).





Attention: Check that all parts of the machine are well fastened before transporting. Before transporting the blade must be removed!
For loading, only use lifting gear and tackle of sufficient capacity. Lift the machine using the lifting eye.

2.12.2 Transporting

Check that all parts of the block saw are well fastened before transporting.

For loading only use lifting gear and tackle of sufficient capacity (kerb weight of the block saw approx. 300 kg - 660 lbs.).

Lift the block saw using the lifting eyes (1); when moving it with a forklift, use only trucks with suitable guiding rollers.

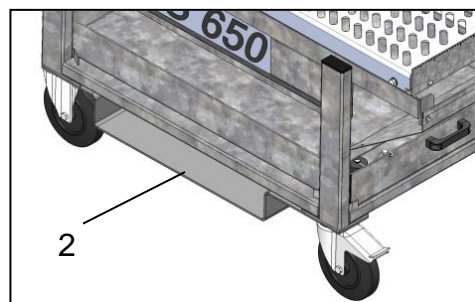
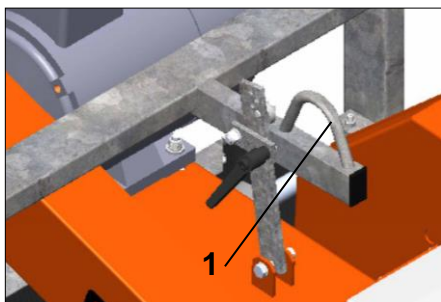

2.13 Store

Store the machine in a dry, high or locked place, out of the reach of children or unauthorized persons. Clean and preserve the machine with corrosion preventive if storing over a longer time like winter time!

Note: Store dismantled blades so, that the blades not exposed to mechanical damages and harmful environmental conditions (UV radiation, temperature, humidity, etc.).



Attention: Store blades just standing or hanging!

3. Preparing for Operation

3.1 Export checking

- Remove the transport packaging and dispose of it in an environmentally responsible way.
- Check the machine for completeness and intactness. For the scope of delivery, see "Shipment and provided accessory".
- Secure the machine against accidental start-up and rolling away.



Attention: Read and observe all operating instructions which are relevant for the machine (block saw,...)!

3.2 Installation

- Keep the working area clean, cluttered areas invite injuries.
- Have the working area well lightened.
- Observe the manufacturer's information for connecting power and water supply. Lay all cables that damages will be prevented.
- Set up the machine on a flat, solid and stable base and fix it with the lockable rollers (1).
- Fix the handgrip (2) with the star knob screw (8) onto the cutting table (3). Then lift the cutting table out of the lock (4).
- Install the cutting blade as described in chapter 3.3.1 and adjust the cutting head (5) to the blade with the clamp lever (6).
- Make sure the machine is in perfect state, then plug in the mains plug (7).

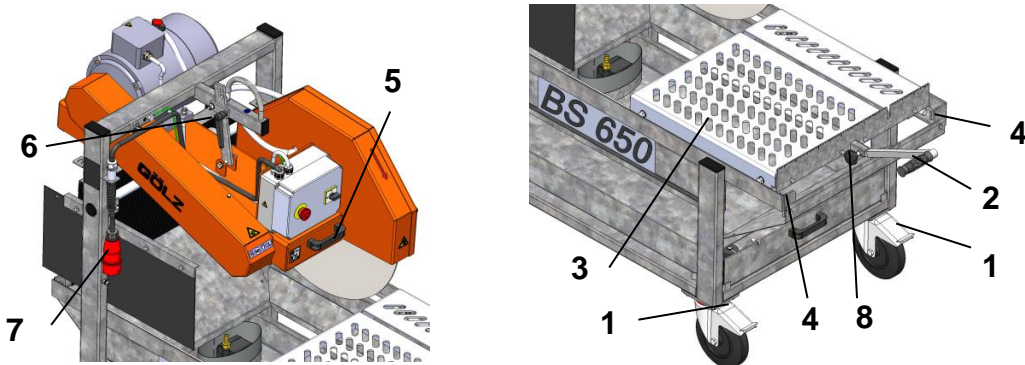

3.3 Blade

The cutting discs must meet the specification of **GÖLZ® GmbH**. Use the corresponding cutting discs depending on the material to be processed, the machining process and the type of work to be performed! When not used properly, no liability is assumed for damages resulting therefrom.

- All used cutting discs must be designed, regarding their maximum admissible cutting speed, for the max. drive speed of the machine.
- For machines with variable drive speed, use cutting discs which, regarding their maximum admissible cutting speed, correspond to the respective maximum drive speed of the machine.
- Never use faulty or damaged blades.
- Check the correct rotation of the blade to the spindle shaft, see arrow on the cutting disc cover!
- Check the blade is well fastened before beginning to operate. Defective cutting discs must be replaced immediately!
- Cut off the engine or disconnect the power supply before mounting or changing blade. After mounting, do not leave any tools, such as open-end spanners, on the machine.
- Use only blades suitable to the blade acceptance (arbor hole, flanges).



Danger: Faulty or damaged blades can cause injuries to the operator and other persons!



Information: Wrong rotation of the blade will result in more wear of the blade!



Danger: Wrong rotation of the blade may result in segments cracking off and can cause injuries to the operator or other persons!

3.3.1 Mounting the blade

Blade mounting:

- Mount the blade to the manufacturer's odds (Observe the min. flange-Ø; use only original screws or nuts).
- Use only blade diameters which are allowed by the manufacturer.

Stop the machine prior to installing or replacing the cutting disc, pull out the mains plug and pull it away from energy sources!



Information: Clean all fastening devices of the blade (flanges, thread of the blade shaft, screws and nuts) before mounting the blade!

- Before mounting disconnect the unit from the mains.
- Loosen screw SW 16 (1) of the cutting blade guard and swing the guard to the side. Loosen screw SW 24 (left-hand thread!) (2) of the cutting shaft and remove the outer flange (3).
- Mount a cutting blade (4) with a location hole of Ø 60 mm and a max. of 650 mm outside diameters.
- Check the correct direction of rotation. Rotation arrows are on the cutting blade guard and the cutting blade.
- Mount the outer flange (3) again and tighten with screw (2). Move cutting blade guard back into position and secure with screw (1) against unintentional opening.

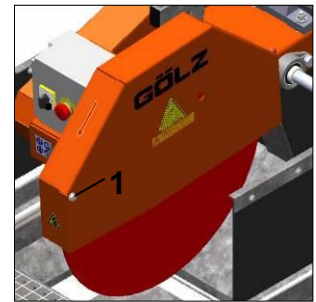
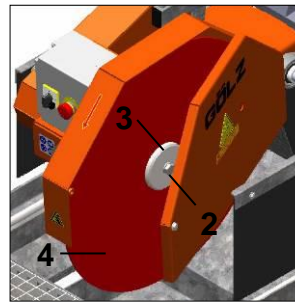
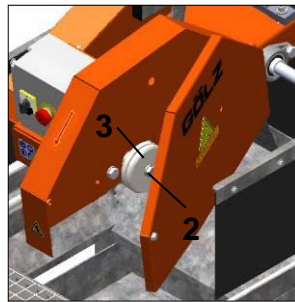

Danger: You are not allowed to operate the device without mounted cutting blade guard!

3.4 Water supply



Important: The operation is to be carried out in wet cutting, in order to prevent the occurrence of harmful particulate matter and to increase the lifetime of the cutting tool.



Attention: Tools which are only designed for wet cutting technique, must never be used without water supply! Always make sure that there is enough water supply!

The supply of water at the cut ensures that the tool is cooled, the dust of the material is bound and the cut is rinsed out.



Attention: Use only water for cutting which is free from coarse impurities! Do not use salt water!

- Check tightness of the drain plug (1) on the water tub and fill the water tub (2) with clean water.

- Put the electric water pump (3) into the water pump case (4). This prevents the pump from being clogged with strongly polluted water.
- The electric water pump (3) is a submersible pump supplied with electricity (230V) from the control box.
- The submersible pump starts running together with the blade drive motor. During the operation, it pumps water via a hose to the ball tap, with which the volume flow can be reduced. Then the water reaches the cutting blade support on two sides and cools the cutting blades or binds the dust.

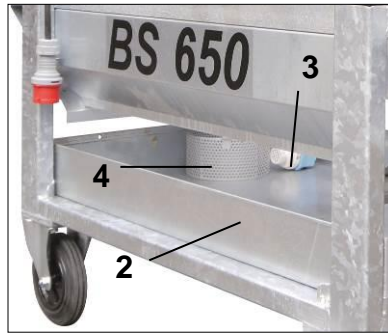
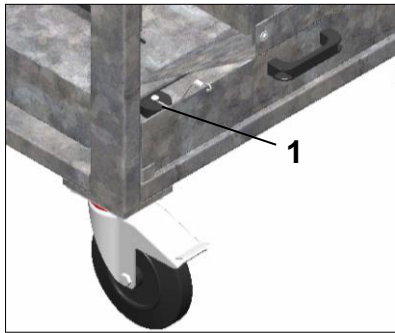

Attention: the water pump must never be allowed to run dry because this destroys the pump!

- To prevent the freeze up of the water system and damage to the block saw, completely drain the water after each use and before longer breaks at temperatures around or below the freezing point.
- Drain the block saw (hoses, water basin) when it is switched off, turn off the machine frost-free and/or cover the machine!



Avoid frost damage!

3.5 Mounting / dismounting fork lift guide

Remove the thread-rolling screw M10x20 (1) of the rollers (3) and steering rollers (2), remove rollers. Mount the fork lift guide (4) between the machine frame and the rollers, as indicated in the picture. Make sure that the longer leg of the forklift guide is under the steering roll. Use the supplied M10x25 screws (5) for mounting.

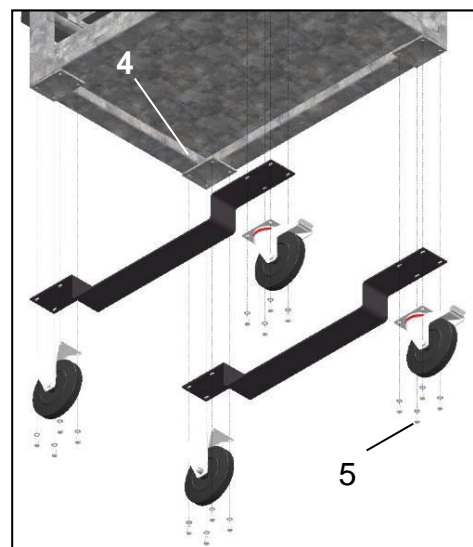
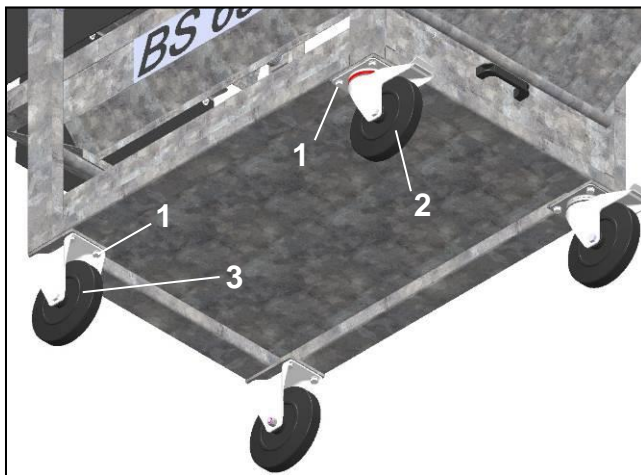

4. Operation



Danger: Never touch rotating parts like blade shaft or blade while operating!

Operating elements

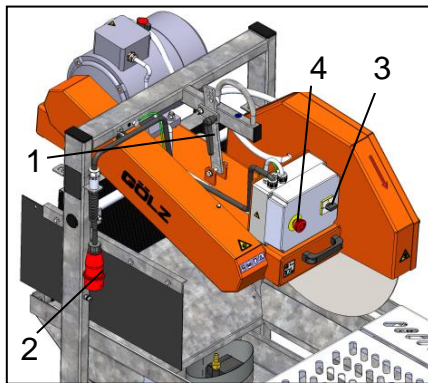

- 1. Cutting depth control
- 2. Main plug/ Main switch
- 3. Star-delta starting switch
- 4. Emergency stopping

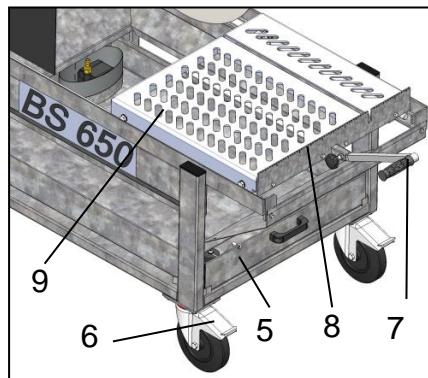

- 5. Water tank
- 6. Fixed roller for heavy loads
- 7. Push rod
- 8. Stop bar
- 9. Cutting table

4.1 Before starting the machine

- Check the machine for safe operating condition:
 - All components must be properly mounted.
 - The functions of the electric engine must function properly.
 - Do not make any changes on operating elements and safety devices.
 - Mains plug must be dry!
- The machine may only be operated in safe operating condition.
- If work is carried out where harmful or explosive substances, such as dust, sludge occur, observe the applicable national regulations.
- If there is a risk that, during the cutting process, material particles are accelerated outwards, wear safety goggles.



Danger: Demolition parts can cause injuries to the operator while cutting!

- When travelling on public roads, ways and places always observe the valid traffic regulations and, if necessary, make sure beforehand that the machine is in a condition compatible with these regulations.
- After operating secure the machine against unintentional moving. If the centre of gravity lies outside the cutting table because of the workpiece dimensions, take suitable measures to provide a workpiece support (e.g. roller bock etc.)
- Wear ear protectors on the workplace during the cutting procedure when endangered by increased noise.



Danger: The sound pressure may exceed 85 dB(A)!

- Appropriate to the application of the machine it could be necessary to wear further protective equipment.



Danger: Down coming parts at the building site can cause injuries to the operator!

- The working area is reserved only for the operator. Keep unauthorized persons out of the working area.
- Make sure the operator always has well sight to the working area. He always has to intervene in the working process. Never operate the machine without mounted safety devices.
- Careless handling can lead to life-threatening injuries caused by the rotating cutting disc. Only operate the machine with fully mounted blade guard.
- Nobody is allowed to remain in the working area nor in the area where falling segments of the cutting disc can be accelerated outwards (minimum safety distance 10m). If this safety distance cannot be respected, the danger zone must be closed or be marked by warning signs.
- Care for the whereabouts of cooling and rinsing water as well as of cutting sludge.
- Cutting sludge must be collected, filtered and disposed of.



Attention: when working in countries with no neutral conductor always use the additional grounding!

4.2 Cutting operation

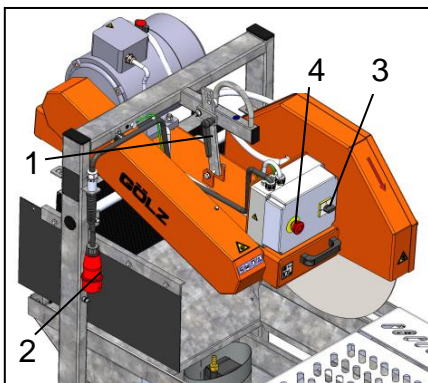

1. Clamping lever
2. Main plug/ Main switch
3. Star-delta starting switch
4. Emergency stopping

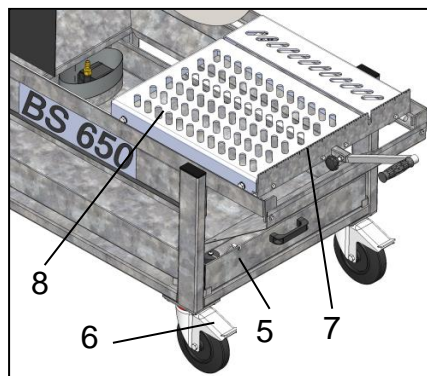

5. Water tank
6. Fixed roller for heavy loads
7. Stop rail
8. Cutting table



Information: To avoid damages to the water pump observe the following information: Operate the water pump only if it is complete under clean water. Clean the water tub before it will get filled with mud. Avoid dry-running of the water pump. Drain the water pump if frost will appear!



Attention: in case of danger immediately switch off the block saw by pushing the emergency stop (4)!

- Make sure the supply voltage is compliant with the voltage mentioned on the motor type plate: **input voltage 400 V/50 Hz, fuse protection 16 A, 5-core cables with neutral conductor.**
- The used power supply must be compliant with the rules for building-site distribution boards (fault-current circuit breaker effective at fault currents of max. 30 mA).
- Use only extension cables of max. 30 m with protective conductor (five-core) and sufficient cable section (min. 1,5 mm²). Always completely unwind cable reels.



Attention: never let cable reels winded-up and never exceed cable lengths of 30 m because this can cause a performance loss of the block saw.

- Make sure the block saw stands on a flat, solid and stable base, then fix it with the lockable rollers (6).
- Connect the mains plug with the plug (2) of the block saw. Check the drain plug of the water tank for proper fitting and fill the water tank (5) with clean water.
- Loosen the clamping lever (1) of the cutting depth control and adjust the desired cutting depth. Move the cutting table (8) and check it has no contact to the blade.
- Place the cutting material on the cutting table and move it to the stop rail (7).
- Open the ball valve at the top of the electric motor. Set the start-up switch (3) on "Stern" (star). When the motor reaches its top speed, set the start-up switch on "Dreieck" (water pump is now running).
- **Notice correct rotation of the electric motor!** Wrong rotation – pull mains plug (2) and turn the phase inverter with a screw driver.



Attention: When the motor gets started, the cutting shaft or the cutting blade immediately rotates. Be sure the starting cutting blade is not a source of danger!

- Operate the push rod (6) with even feed and in dependence to the material to be cut.
 - **Feed to high - motor overstress!**
 - **Feed to low - dull segments!**

4.3 Stop cutting operation

- After cutting move back the cutting table.
- Set the start-up switch in **0-position**. **In case of danger always switch off the machine with the emergency stop.**
- Close the ball valve placed on the electric motor and take out the cutting material.

4.4 Changing the blade

The blade must be changed if:

- the diamond segments of the blade are completely worn
- the material to be cut changes

- the blade turns irregularly
- the diamond segments are damaged or broken

For fitting a new blade, proceed as described in the chapter "Mounting the blade".

5. Maintenance

5.1 General

In case of maintenance works chapter 2.6 of this manual must also be observed.

	Attention: pull off the mains plug before cleaning the machine!
	Information: Clean the machine after every operation. Observe local environmental regulations!
	Attention: Drain the water pump if frost will appear!
	Attention: Work on the electrical system or equipment may only be carried out by a skilled electrician!

In accordance to the given cycles, the subsequently described maintenance work has to be enforced. Also the wearing part subject to no certain maintenance intervals has to be checked regularly for wear and to adjust if necessary or to exchange.

		Before starting work	After work	Per working day	After 10 operating hours	Weekly	After 1 month	After 3-6 month	Yearly	In the event of a malfunction	If damaged
Complete machine	clean		x								
	Optical control (Condition, tightness)	x								x	
	Change, substitute										x
Electrical system	Optical control (Condition, tightness)	x									
	Legal safety inspection								x		
	Change, substitute										x
Reachable nuts and screws	retightening, setting					x					

		Before starting work	After work	Per working day	After 10 operating hours	Weekly	After 1 month	After 3-6 month	Yearly	In the event of a malfunction	If damaged
Tool holder (flanges and blade holder)	clean	x									
	Lubrication, greasing, oiling, corrosion protection		x								
	Optical control (Condition, tightness)	x									
	Change, substitute										x
Tool (cutting blade)	Optical control (Condition, tightness)	x									
	Check for change	x									
	clean		x								
	Change, substitute										x
Controls (Handles, locking wheels, etc.)	Optical control (Condition, tightness)	x									
	clean		x								
	retightening, setting					x					
	Change, substitute										x
Water tank and hoses	Optical control (Condition, tightness)	x									
	clean		x								
	Change, substitute										x
V-belts	Optical control (Condition, tightness)	x									
	retightening, setting				x						
	Change, substitute								x		x
Water pump	Optical control (Condition, tightness)	x								x	
	clean		x								
	Change, substitute										x
Cutting head, Cutting table	Optical control (Condition, tightness)	x								x	
	Lubrication, greasing, oiling, corrosion protection	x									
	clean		x								
	retightening, setting					x				x	
	Change, substitute										x
Motor housing	clean		x								

		Before starting work	After work	Per working day	After 10 operating hours	Weekly	After 1 month	After 3-6 month	Yearly	In the event of a malfunction	If damaged
Motor	Optical control (Condition, tightness)	x									
	Legal safety inspection								x		

5.2 Water pump und water tank

- Remove wastewater.
- Remove sludge deposits on the water basin bottom.
- Take off the water pump and put it in a bucket.
- Plug in the mains plug and let the block saw run for 1 or 2 minutes. Unplug the mains plug and insert the water pump back in the machine. This will prevent the pump wheel to block because of sludge deposits.

5.3 Motor

- The motor needs little maintenance.
- To prevent overheat clean periodically the ventilator cowl and the cooling ribs of the electric motor.

5.4 Lubricating chart

- Lubrication nipples are situated at the bearings of the cutting head and the blade shaft (inside to blade shaft).
- For lubricating, use synthetic fat with high temperature resistance.
- Grease the bearings of the blade shaft and cutting head every 40 working hours with heat resistance fat
- All other moving parts should be held free of dirt and dust and be greased from time to time.

5.5 V-belt

Check the v-belt tension every 100 operating hours. The v-belt cover must be removed to do so. New v-belt must be checked after approximately 20 operating hours and be replaced only as a set. The v-belts must be replaced when a further stretching is no longer possible and when the v-belts are damaged (ragged, porous etc.).

- To stretch the v-belts (3) first loosen the screws (1) of the v-belt cover, then take off the v-belt cover (2).
- Then loosen the motor fixing screws (4) and adjust the right tension with the adjusting screw (5). You can also loosen up the v-belts this way to replace them.
- Retighten the motor fixing screws and fit the v-belt cover.

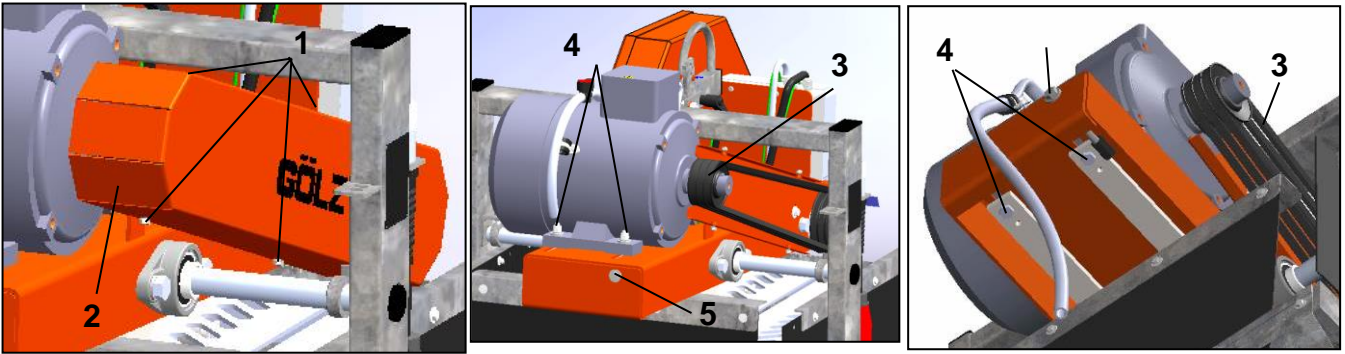

Attention: Do not use sharp or pointy items to tighten the v-belts, thus avoiding damage which leads to the destruction of the v-belts.

5.6 Cutting table



Information: let only qualified personnel do adjustment work, especially adjust the angle between the cutting table and the cutting blade.

The cutting table should/must be oriented when the saw blade often clamps and the cuts are not square. To do this, you must orient the rollers between the cutting table and the guidance laterally as well as forward and backward.

Orient the cutting table as follows:

- Fit a cutting blade.
- Set a right-angled angle of sufficient length on the cutting table and slide the angle laterally to the stationary cutting blade!
- Now you can adjust the side inclination. The angle must fit clearance-free.
- Loosen the fixing screws of the roller which is to be adjusted (2).
- Move the cutting table toward the angle until the angle and the cutting blade are aligned.
- Retighten in this position the fixing screws of the roller (2).

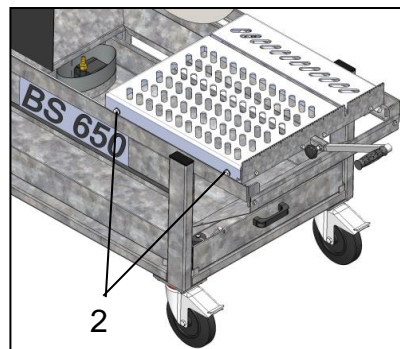
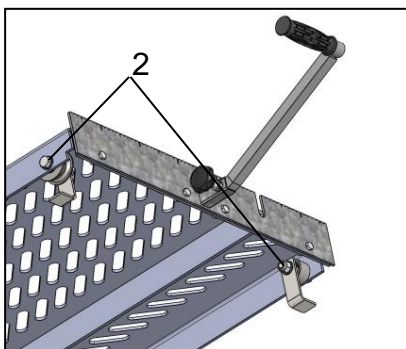

5.7 Machine

- Switch off the machine for maintenance and repair work.
- Always pull out the mains plug when working on the machine.

- After cutting clean the machine and check for damages.
- Necessary repairs must be carried out immediately (see spare parts list).

5.8 Blade

When ending a cutting job - check blade as follows:

Check segments for cracks or break-outs, Cracks between segment and core barrel, deformation and out of round wear.

In case of doubt, send the blade for repair.

6. Taper bushes installation instructions

6.1 To assemble

Clean and de-grease the bore and taper surfaces of the bush and the tapered bore of the pulley. Insert the bush in the pulley hub and line up the holes (half thread holes must line up with half straight holes).

Lightly oil the grub screws or the cap screws and screw them in, do not tighten yet.

Clean and de-grease the shaft. Fit pulley with taper bush on shaft and locate in desired position.

When using a key it should first be fitted in the shaft keyway. There should be a top clearance between the key and the keyway in the bore.

Using a hexagon socket wrench gradually tighten the grub/cap screws in accordance with the torques as listed in the schedule of screw tightening torques. When the drive has been operating under load for a short period (half to one hour) check and ensure that the screws remain at the appropriate tightening torque. In order to eliminate the ingress of dirt fill all empty holes with grease.

6.2 Removal

Slacken all screws. Depending on the size of the bush remove one or two. After oiling point and thread of grub screws or under head and thread of cap screws, insert them into the jacking off hole(s) in bush.

Tighten screw (s) uniformly and alter neatly until the bush is loose in the hub and pulley is free on the shaft. Remove pulley bush assembly from shaft.

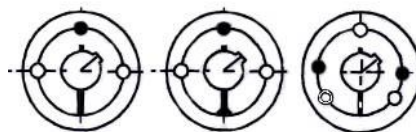

Bush	Screw tightening torques (Nm)	Screw	
		Quantity	Size
1008 1108	5.6	2	1/4" BSW
1310 1315	20	2	3/8" BSW
1210 1215	20	2	3/8" BSW
1610 1615	20	2	3/8" BSW
2012	31	2	7/16" BSW
2517	48	2	1/2" BSW

Bush	Screw tightening torques (Nm)	Screw	
		Quantity	Size
3020 3030	90	2	5/8" BSW
3535	112	3	1/2" BSW
4040	170	3	5/8" BSW
4545	192	3	3/4" BSW
5050	271	3	7/8" BSW

7. Troubleshooting



Attention: In the event of changes in the behaviour of machine during operation, stop the machine immediately and report the malfunction to the competent authority/person!

Problem	Cause	Remedy
Machine		
Machine doesn't work when switched on	Mains plug not correctly plugged in.	Check correct connection to the power supply
	Mains plug defective	Check mains plug function and replace if necessary
	Loosened connection in the electrical installation	Have the whole electrical installation checked by an electrician
	Driving motor defective	Have the driving motor checked by an electrician and replaced if necessary
Machine performance is insufficient	Mains plug too long, cable reel is rolled up.	Observe the prescribed mains plug length. Unwind cable reel
	Insufficient performance of the local power supply	Pay attention to and observe machine connection data
	Motor runs on a star connection	Continue delta connection
	Driving motor doesn't keep the speed any more	Have the driving motor checked by an electrician and replaced if necessary
	V-belt slips through	Retighten v-belt and replace it if necessary
Little or no cooling water flow	The water pump draws air.	Add water; pivot the sucking side of the water pump downward.
	Hoses clogged	Clean hoses.
	Hose bent	Check hose installation.
	Hose is leaky or loosened.	Replace or correctly fix hose.
	Water pump wheel dirty (sieve)	Clean pump wheel or sieve.
	Water pump doesn't work.	Have the electrical connection to the water pump checked and if necessary replaced by an electrician.
Motor runs, saw blade stops under load	V-belt loosened	Retighten and if necessary replace the v-belt.
	Belt pulley worn-out	Replace belt pulley and v-belt.
	Blade shaft screw has loosened.	Check screw seating and retighten if necessary.

Problem	Cause	Remedy
Electric motor		
Electric motor does not operate!	Fuse has blown.	Install new fuse.
	Motor protection tripped.	Check correct adjustment of motor protection and adjust
	Motor protection does not switch, error in control unit.	Check control unit of motor protection and correct error.
	Mains plug not connected	Check connection
	Fuse of power distribution on building sites has been released	Check fuses
	Motor protection has turned off.	Wait about 5 minutes and start motor again.
Motor doesn't start or starts difficultly	Intended for delta connection yet star connected.	Correct circuit.
	Voltage or frequency strongly deviates from nominal value, at least when switching on the device.	Provide for better mains condition.
Motor doesn't start in star connection, but in delta connection	Insufficient torque value for star connection	If delta connection not too high, switch on directly; else larger motor or special model after consultation.
	Contact fault at delta star switch.	Correct error.
Motor too hot (can only be assessed through measuring)	Motor in delta connection instead of star as intended	Correct connection.
	Mains voltage deviates from motor nominal voltage by more than 5%. Higher voltage has a particularly adverse effect in multi-pole motors, since in these no-load voltage is already close to the nominal voltage under normal voltage.	Provide for correct nominal voltage
	Cooling air quantity too low, cooling air channel clogged.	Ensure unobstructed access and discharge of cooling air.
	Cooling air is preheated.	Provide for fresh air.
	Overload under normal mains voltage, current too high, rotational speed too low	Build in a larger actuator (determine via power measurement)
	Nominal operating mode (p.1 up to p.8 DIN 57530) exceeded. If e.g. the motor gets too hot in consequence of too high a starting frequency, it will not be enough to just use a larger motor since it would result into the same ratios.	Adapt nominal operating modes to prescribed operation conditions. We advise to consult a specialized technician to determine the correct actuator.
	Loose connection in supply line (intermittent two-phase failure!).	Repair loose connection.
Motor is humming und has high current consumption	Winding defective.	Bring motor for repair to specialist.
	Rotor maybe blocked	Check drive.

Problem	Cause	Remedy
Electric motor		
Fuses blow or motor protection starts immediately.	Short circuit in line or motor.	Remove short circuit.
	Motor has short circuit to frame or interturn short circuit.	Have a specialist remove the error.
	Motor wrongly connected.	Correct connection.
Wrong direction of rotation	Motor wrongly connected	Interchange two phases.
Winding damages		Motor needs to be brought to specialist for repairs.
Cutting		
Abnormal wear-out of segments!	Soft bonded segments	Use segments one class harder bonded or reduce feed
	Segments too narrow	Use blade with wider segments or reduce feed
	Too few segments	Use blade with more segments
	Blade deformed	Replace the blade and have the blade shaft checked
	Blade runs untrue	Have the cutting head adjustment checked
	Abrasive material	Use segments one class harder bonded
	Feed too high	Reduce feed
Cutting blade has lateral and radial run-out	Cutting blade twisted or damaged	Have the cutting blade levelled, weld segments onto a new blade or replace cutting blade.
	Dirty flanges	Clean flanges
	Blade shaft twisted	Replace it.
Cutting blade wobbles	Bad blade tension	Return cutting blade.
Segments loosen	Overheated, insufficient cooling	Reweld segments, check cooling water adduction
No power when cutting, cutting blade blunt	Cutting blade not adapted to material	Use right cutting blade
	Cutting blade not adapted to machine power	
	Cutting blade too hard	
	Diamonds on segment are blunt	Sharpen
Cutting course not optimal	Segments blunt	Sharpen
	Cutting blade under excessive load	Use appropriate cutting blade
	Bad cutting blade tension	Return cutting blade
Location bore for the cutting blade has levelled off	Cutting blade has turned on the cutting shaft	Check and replace cutting shaft if necessary
		Turn out location bore and fit in exact ring
Cutting blade has started	Cutting blade overheats, insufficient cooling water	Check cooling water adduction
	Side friction due to cutting course	Reduce forward feed, slowly pull through the material

Problem	Cause	Remedy
Cutting		
Cracks in the steel core; eccentric wear on the cutting blade	Cutting blade too hard	Use softer cutting blade
	Cutting shaft run in	Replace cutting shaft
	Too much bearing clearance	Replace bearings

8. Spare parts list

8.1 Using the spare parts list

The spare parts list is not a mounting or dismounting instruction. The only purpose of the spare parts list is to easily and quickly find spare parts which can be ordered with distribution agencies, see chapter 8.1.3 "Distribution agencies".

8.1.1 Safety regulation



Danger: Mounting or dismounting assembly groups can give rise to risks which are not mentioned in the spare parts list!

Using this spare parts list for mounting or dismounting purposes is not permitted. For assembly and disassembly work exclusively the corresponding descriptions in this operating manual are to be followed.







Danger: Non-observance of this instruction can result in injury which, in the worst case, can result in death!

8.1.2 Ordering information

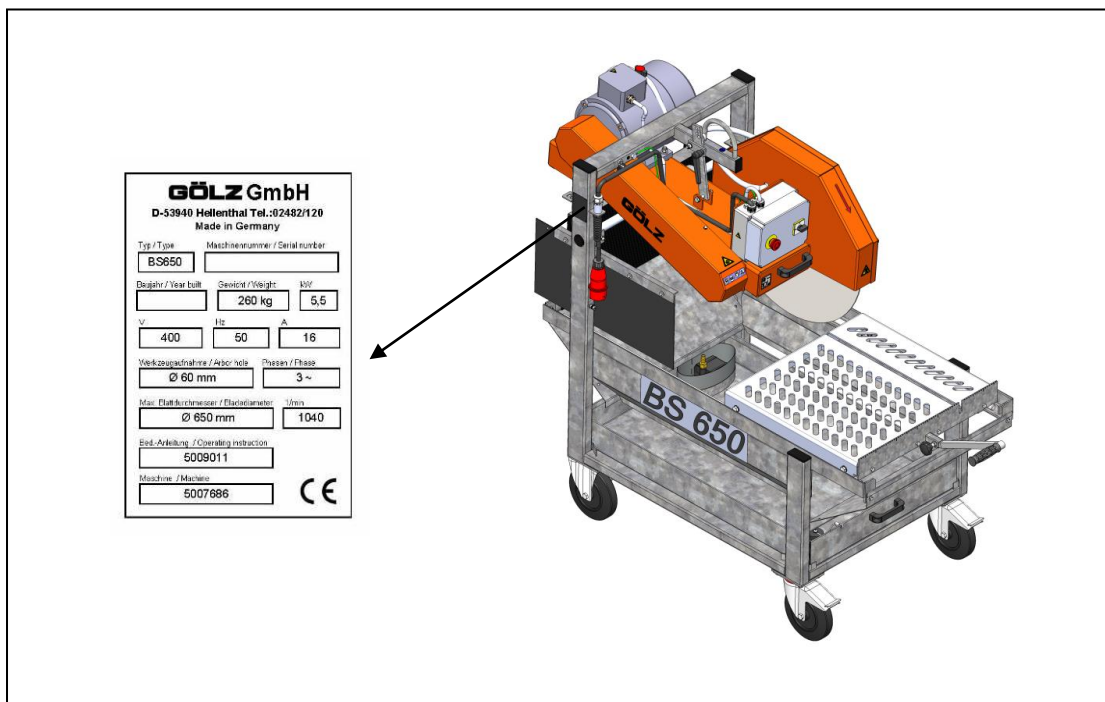

Note: In order to avoid wrong deliveries the information the ordering information should be checked for accuracy and completeness before sending it! Completely indicate the delivery address!



		
So bekommen Sie schnell und richtig Ihr Ersatzteil	Always indicate	Pour obtenir rapidement les pièces de rechange indiquer
<ul style="list-style-type: none"> • Maschinentyp gemäß Typenschild • Baujahr gemäß Typenschild • Artikelnummer gemäß Ersatzteilliste • Maschinennummer gemäß Typenschild 	<ul style="list-style-type: none"> • machine type according to nameplate • year of manufacture according to nameplate • order number according to spare part list • serial number according to nameplate 	<ul style="list-style-type: none"> • type de la machine conforme de plaque d'identification • Année de construction selon plaque d'identification • Numéro de l'article selon la liste des pièces de rechange • numéro de la machine conforme de plaque d'identification
Für Bestellungen, Fragen und Informationen wenden Sie sich bitte an die zuständigen Stellen.	For orders, questions and information, please contact the competent departments.	Pour les commandes, questions et informations, veuillez-vous adresser aux points de ventes correspondants.

8.1.3 Distribution agencies

Deutschland – Germany - Allemagne GÖLZ® GmbH Dommersbach 51 DE-53940 Hellenthal Tel: +49 (0)2482-12 200 Fax: +49 (0)2482-12 222 E-Mail: info@goelz.de / Internet: www.goelz.de	
Österreich - Austria - Autriche GÖLZ® Ges.m.b.H Samstraße 52 A-5020 Salzburg Tel: +43 (0) 662 - 43 81 75 Fax: +43 (0) 662 - 43 07 34 E-Mail: info@goelz.at / Internet: www.goelz.at	Frankreich - France - France GÖLZ® S.A.S. 1, rue de la Mairie F-67370 Berstett Tel: +33 (0)3.88.59.43.00 Fax: +33 (0)3.88.59.47.77 E-Mail: info@golz.fr / Internet: www.golz.fr
Großbritannien - Great Britain - Grande-Bretagne GÖLZ® (UK) Ltd. Unit A5, Springhead, Enterprise Park Northfleet Kent DA11 8HB Tel: +44 1 474321679 Fax: +44 1 474321477 E-Mail: info@goelz.co.uk / Internet: www.goelz.co.uk	Benelux GÖLZ® Benelux Eupener Straße 61 BE-4731 Raeren-Eynatten Tel: +49 (0)2482-12 200 Fax: +49 (0)2482-12 222 E-Mail: benelux@goelz.de / Internet: www.goelz-online.com
Australien - Australia - Australie GOLZ® Pty Ltd. 44 Stanley Street Peakhurst, NSW 2210 Tel: +61 (0) 2 9534 5599 Fax: +61 (0) 2 9534 5588 E-mail: info@golz.com.au / Internet: www.golz.com.au	USA GOLZ® L.L.C. 5860 East Osage Ridge Lane Columbia MO 65203-6018 Tel: +1 573 474 4961 E-Mail: info@golzusa.com / Internet: www.goelz-online.com

8.2 Wearing parts

Wearing parts for construction devices mentioned in the operating manual such as drilling and sawing machines.

Wearing parts are the parts subject to operation-related (natural) wear during proper use of the device. The wearing time cannot be uniformly defined, and differs according to the intensity of use. The wearing parts must be adjusted, maintained and, if necessary, replaced for the specific device in accordance with the manufacturer's operating manual. Operation-related wear is not a reason for defect claims.

Wearing parts of this machine are grey marked in the spare parts list.

- Feed and drive elements such as toothed racks, gearwheels, pinions, spindles, spindle nuts, spindle bearings, cables, chains, sprockets, belts
- Seals, cables, hoses, packings, connectors, couplings and switches for pneumatic, hydraulic, water, electrical and fuel systems
- Guide elements such as guide strips, guide bushes, guide rails, rollers, bearings, sliding protection supports
- Clamping elements for quick-separating systems
- Flushing head seals
- Slide and roller bearings that do not run in an oil bath
- Shaft oil seals and sealing elements
- Friction and safety clutches, braking devices
- Carbon brushes, commutators / armatures
- Easy-release rings
- Control potentiometers and manual switching elements
- Securing elements such as plugs, anchors, screws and bolts
- Fuses and lamps
- Auxiliary and operating materials
- Bowden cables
- Discs
- Diaphragms
- Spark plugs, glow plugs
- Parts of the reversing starter such as the starting rope, starting pawl, starting roller and starting spring
- Sealing brushes, rubber seals, splash protection cloths
- Filters of all kinds
- Drive rollers, deflection rollers and bandages
- Cable anti-twist elements
- Running and drive wheels
- Water pumps
- Cut-material transport rollers
- Drilling, parting and cutting tools
- Energy storage

9. Exploded view and spare parts list

9.1 Frame

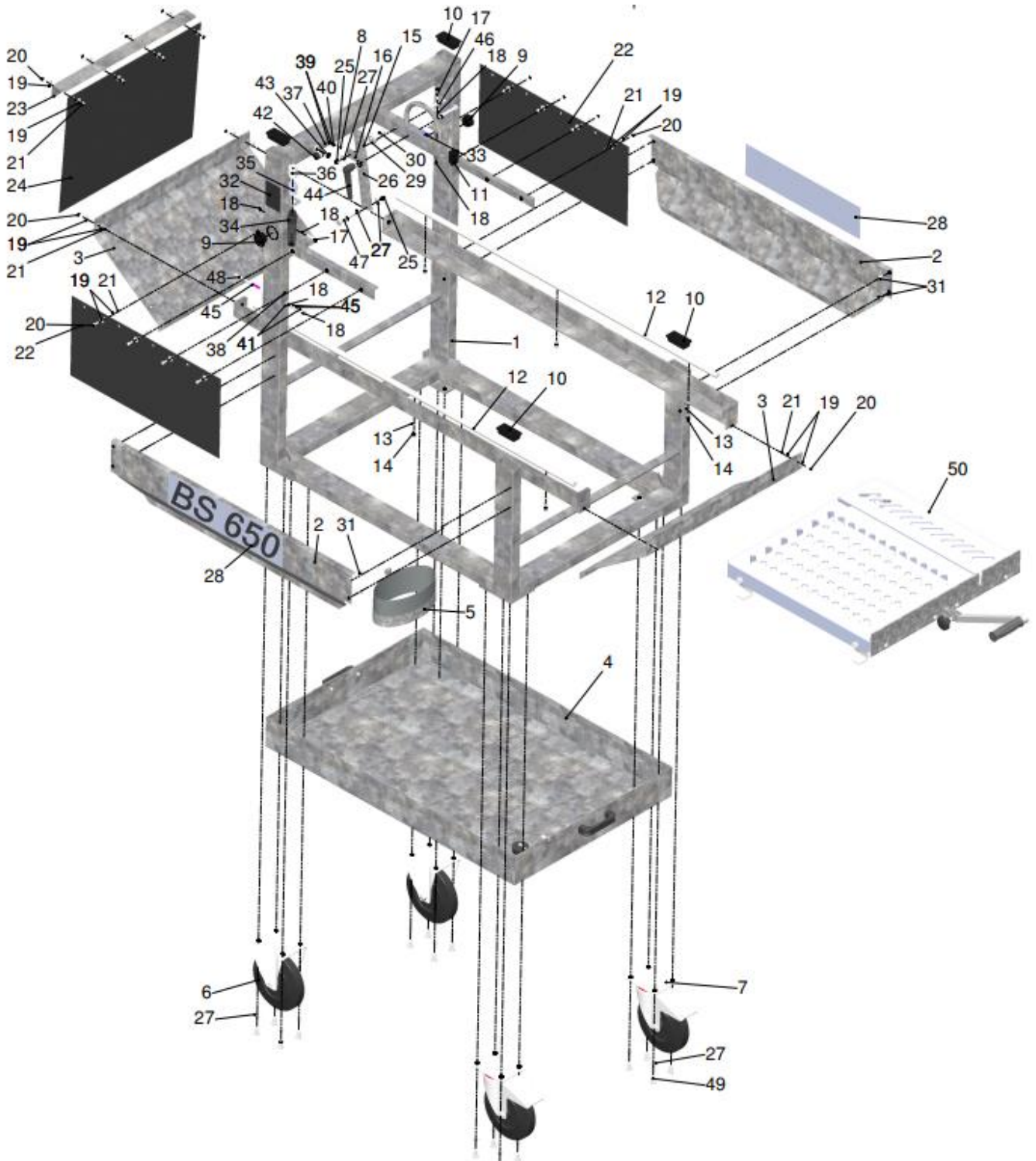

Pos.	K.-Art.-Nr.	Art.-Nr.	Qty.	Norm	Info	Bezeichnung	Description	Désignation
1	5007672	0282 650 9000	1			Grundgestell	Frame	Châssis
2	3003178	0282 650 0130	2			Seitenschutzblech	Side sheet metal	Tôle latéral
3	2002501	0282 650 0124	2		700x1,5x456	Auffangblech	Sheet metal	Tôle
4	5007682	0282 650 9040	1			Wanne kpl.	Water tub complete	Cuve d'eau complete
5	5005189	0282 650 0129	1			Pumpenkasten	Case	Carter
6	5005198	0282 650 0133	2			Bockrolle	Roller	Poulie
7	5005197	0282 650 0132	2			Lenkrolle	Steering roller	Galet de direction
8	5008702	0288 900 0521	1	M5x16 ISO 4017		Schraube	Screw	Vis
9	5007640	0282 650 9050	2			Rundstopfen	Plug	Bouchon
10	5007641	0282 650 9051	4			Rechteckstopfen	Plug	Bouchon
11	5007654	0282 650 9052	1			Rechteckstopfen	Plug	Bouchon
12	3003309	0282 650 0128	2			Laufschiene	Guiding rail	Glissière
13	5001256	0298 900 0008	6	A8,4 ISO 7093		Scheibe	Washer	Rondelle
14	5000565	0295 000 0466	6	M8x20 ISO 4762		Schraube	Screw	Vis
15	5000792	0286 570 0046	1	M10 ISO 4032		Mutter	Nut	Ecrou
16	5007683	0282 650 9055	1			Druckplatte	Pressure plate	Plaque de pression
17	5000601	0281 045 0060	2	M8x40 ISO 4026		Gewindestift	Set screw	Vis sans Tête
18	5000791	0281 045 0025	4	M8 ISO 4032		Mutter	Nut	Ecrou
19	5001282	0298 900 0006	32	A6,4 ISO 7093		Scheibe	Washer	Rondelle
20	5000711	0295 000 0442	16	M6x18 ISO 4017		Schraube	Screw	Vis
21	5000855	0281 045 0027	16	M6 ISO 7040		Mutter	Self locking nut	Écrou
22	5007685	0282 650 9061	2		650 x 360	Gummimatte	Rubber matting	Tapis de caoutchouc
23	5007647	0282 650 9060	1			Halter Spritzschutz	Splash guard fixing	Support de bavette
24	4003399	0282 650 0152	1		600 x 450	Gummimatte	Rubber matting	Tapis de caoutchouc
25	5000857	0286 570 0052	2	M10 ISO 7040		Mutter	Self locking nut	Ecrou
26	4003169	0282 650 0106	1			Vellierleiste	Cutting depth indicator	Barre graduée
27	5000342	0286 570 0047	19	B10,5 ISO 7090		Scheibe	Washer	Rondelle
28	5007656	0295 899 0062	2		BS650	Aufkleber	Sticker	Autocollant
29	4003171	0282 650 0105	1			Einstellring	Adjusting ring	Rondelle de positionnement
30	5000731	0295 000 0187	1	M10x20 ISO 4017		Schraube	Screw	Vis
31	5008066	0295 630 0017	8	4,8x16	gr. Kopf	Blindniet	Blind rivet	Rivet aveugle
32	5006868	0295 899 0054	1		63x94x0,5	Typenschild	Name plate	Plaque signalétique
33	5006788	0295 300 0044	1		Hebepunkt	Aufkleber	Sticker	Autocollant
34	5000244	0283 400 0040	1	M25x1,5		Biegeschutz	Bend protection	Protection de courbure

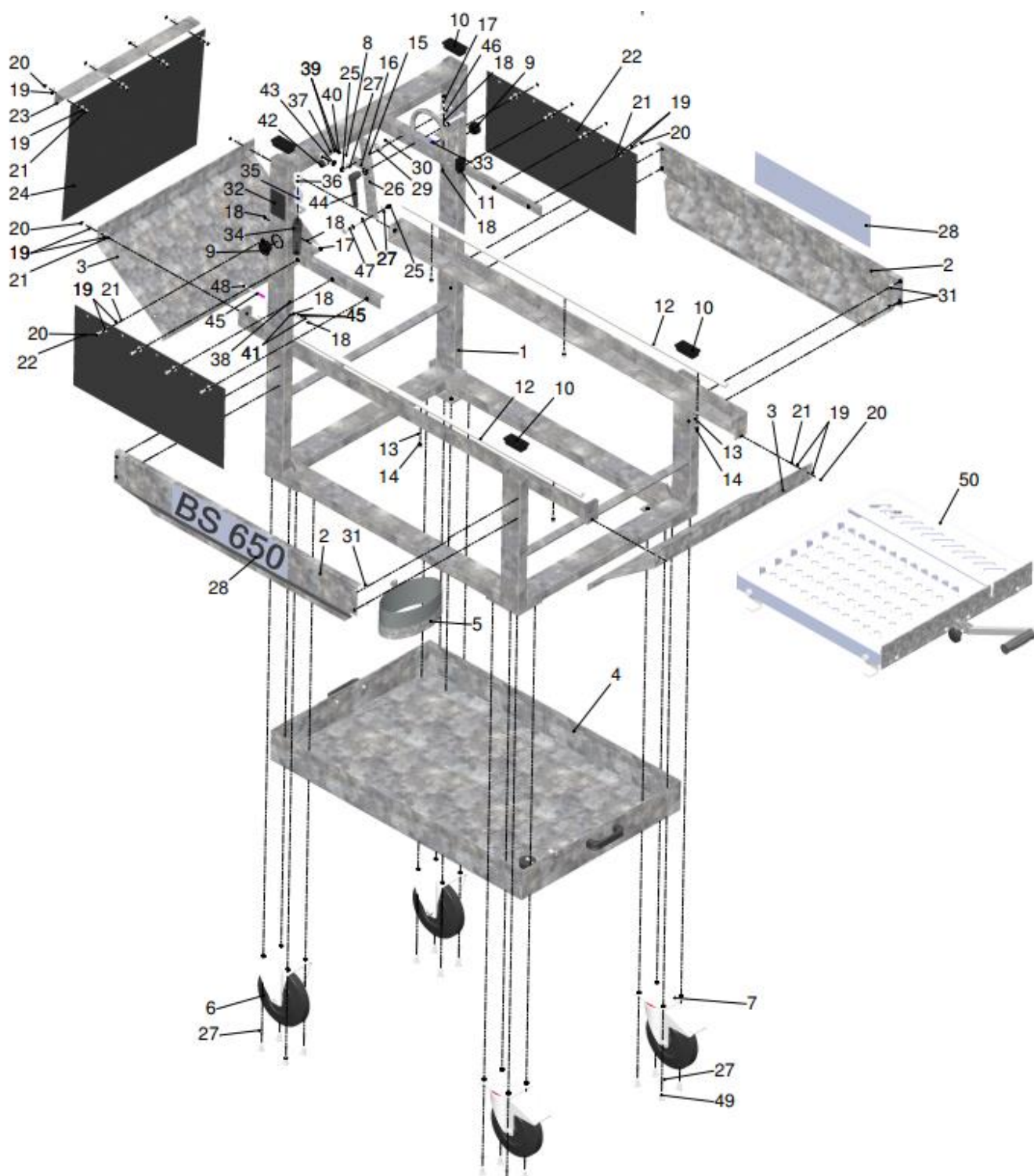

Pos.	K.-Art.-Nr.	Art.-Nr.	Qty.	Norm	Info	Bezeichnung	Description	Désignation
35	5008663	0282 650 0012	1		SVM25W DN	Gewindemuffe	Threaded sleeve	Manchon fileté
36	5006705	0282 252 0341	1	M 25 x 1,5		Kabelverschraubung	Cable connection	Raccord de câble à vis
37	5008688	0283 300 0293	1		Erdung	Aufkleber	Sticker	Autocollant
38	5008665	0295 899 0349	1		PE	Aufkleber	Sticker	Autocollant
39	5008701	0298 000 0104	2	M5		Kontaktscheibe	Contact Washer	Rondelle de contact
40	5000332	0295 000 0170	1	A5,3 ISO 7089		Scheibe	Washer	Rondelle
41	5008707	0298 000 0108	2	M8		Kontaktscheibe	Contact washer	Rondelle de contact
42	5007697	0281 350 0085	1	RSGU 1.15/12		Normaschelle	Hose clamp	Collier
43	5008708	0282 650 9018	1	5,6x19		Kombi-Blechschaube	Tapping screw with washer	Vis à tôle avec rondelle
44	5008766	0282 650 9041	1			Klemmhebel	Clamping lever	Levier de serrage
45	5000341	0282 250 0006	3	B8,4 ISO 7090		Scheibe	Washer	Rondelle
46	5007824	0276 650 9008	2	M10x70 ISO 4017		Schraube	Screw	Vis
47	5000665	0284 650 0034	1	M10x70 ISO 4014		Schraube	Screw	Vis
48	5000657	0282 120 0063	1	M8x100 ISO 4014		Schraube	Screw	Vis
49	5008765	0282 650 9003	16	M10x20 DIN 7500		Gewindefurchenschraube	Thread rolling screw	Vis à tête fraisée
50	6002289	0282 650 9010	1			Schnittguttisch kpl.	Cutting table complete	Table de travail complete

9.2 Cutting head

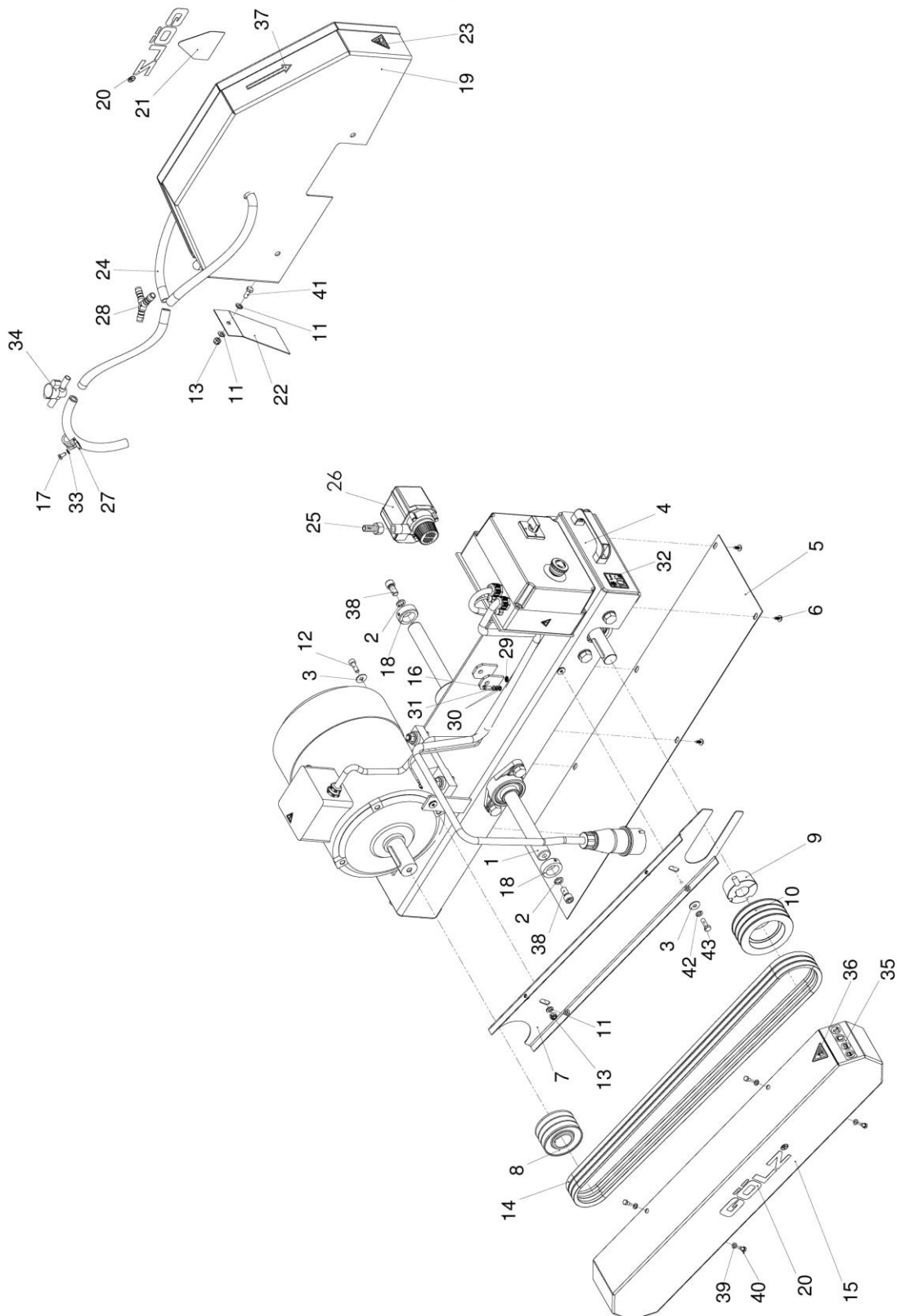

Pos.	K.-Art.-Nr.	Art.-Nr.	Qty.	Norm	Info	Bezeichnung	Description	Désignation
1	5007699	0282 650 9065	1			Pendelwelle	Pendulum shaft	Arbre oscillant
2	5007684	0276 650 9015	2	A13 ISO 7062		Scheibe	Washer	Rondelle
3	5001256	0298 900 0008	2	A8,4 ISO 7093		Scheibe	Washer	Rondelle
4	5007693	0282 650 9070	1			Motorträger kpl.	Cutting head complete	Support du moteur complete
5	5007692	0282 650 9062	1		1,5 x 239 x 934	Abdecklech	Cover	Couvercle
6	5008708	0282 650 9018	6	5,6x19		Schraube	Screw	Vis
7	5007649	0282 650 9025	1			Keilriemenschutz innen	Inner V-belt guard	Protection intérieure
8	5005537	0282 650 0160	1	Ø85x3 SPA Ø38 H7		Keilriemenscheibe	V-belt pulley	Poulie à gorge
9	5003551	0282 190 0412	1	TL2012 Ø30		Taper Lock Buchse	Taper lock bushing	Taper Lock Buchse
10	5007636	0282 650 9053	1	3SPA Dw118 / TL2012		Keilriemenscheibe	V-belt pulley	Poulie à gorge
11	5000341	0282 250 0006	4	B8,4 ISO 7090		Scheibe	Washer	Rondelle
12	5000567	0295 000 0228	1	M8x25 ISO 4762		Schraube	Screw	Vis
13	5000856	0282 065 0005	2	M8 ISO 7040		Mutter	Self locking nut	Écrou
14	5007643	0282 650 0047	1	XPA 1700 Lw	3 Stück	Keilriemen	V-belt	Courroies
15	5007648	0282 650 9020	1			Keilriemenschutzhaube	Outer V-belt guard	Capot protecteur
16	5008702	0288 900 0521	1	M5x16 ISO 4017		Schraube	Screw	Vis
17	5000708	0295 000 0370	1	M6x12 ISO 4017		Schraube	Screw	Vis
18	5000512	0282 150 0017	2	A30 DIN 705		Stellring	Adjusting ring	Bague d'arrêt
19	5007644	0282 650 9030	1			Schutzhaube	V-belt guard	Protection
20	5007410	0295 899 0020	2			Aufkleber	Sticker	Autocollant
21	6001524	0282 650 9058	1		Drehzahl Drehrichtung	Aufkleber	Sticker	Autocollant
22	5007696	0282 650 9063	1			Spritzschutzblech	Splash guard fixing	Support de bavette
23	5006438	0295 899 0348	1		Warnung vor Schnittverletzung	Aufkleber	Sticker	Autocollant
24	5005582	0298 100 0160	1,5 m	13 x 3		Schlauch	Hose	Nozzle
25	5005203	0282 650 0010	2	R1/2" 1xØ13		Schlauchtülle	Nozzle	Embout à olive
26	5005530	0282 650 0179	1		G535C	Wasserpumpe	Water pump	Pompe d'eau

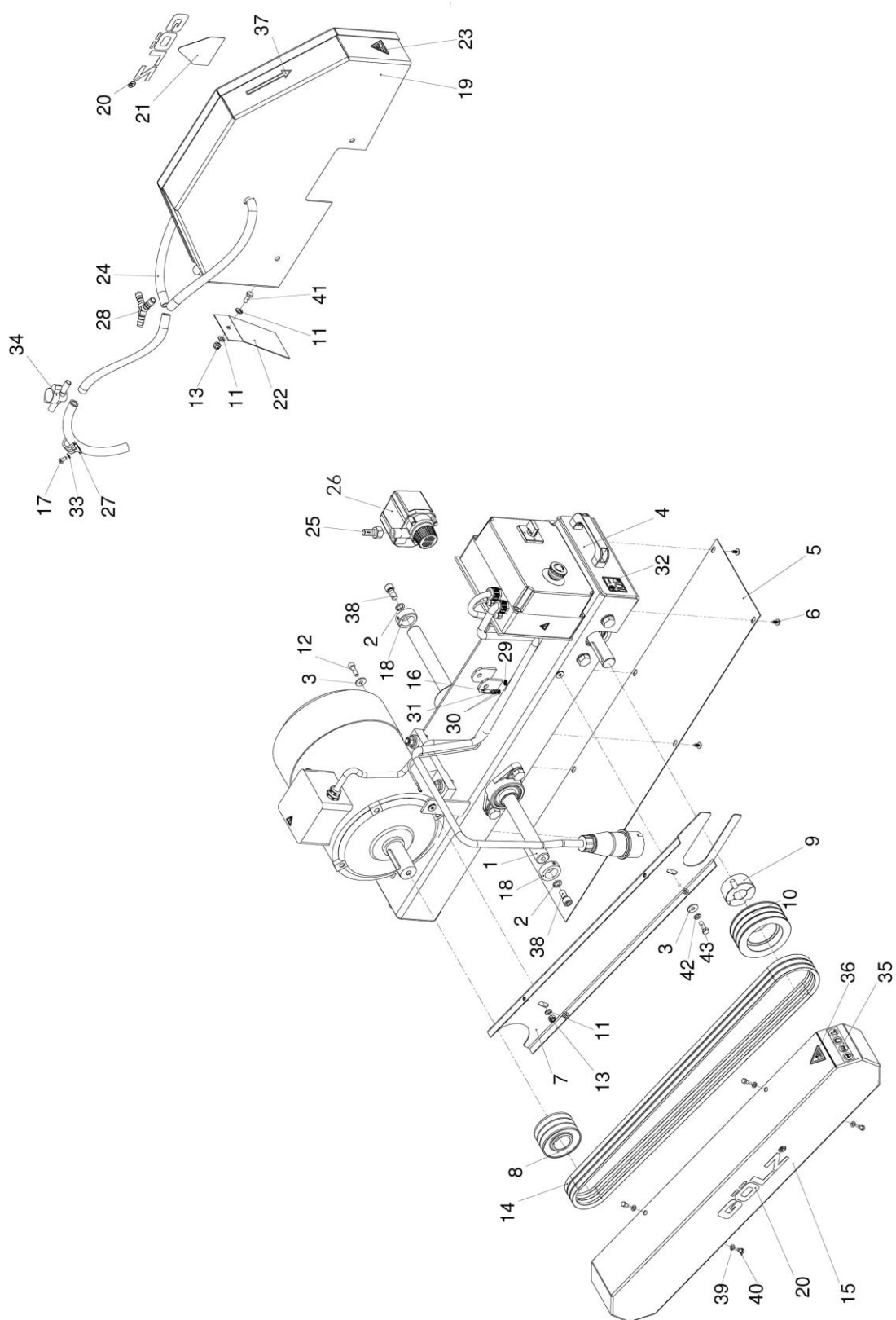

Pos.	K.-Art.-Nr.	Art.-Nr.	Qty.	Norm	Info	Bezeichnung	Description	Désignation
27	5002506	0267 113 0095	1	RSG1.20-22		Normaschelle	Hose clamp	Collier
28	5005206	0282 650 0151	1	Ø 13		Y-Stück	Connection	Raccord
29	5008688	0283 300 0293	1		Erdung	Aufkleber	Sticker	Autocollant
30	5008701	0298 000 0104	2	M5		Kontaktscheibe	Contact Washer	Rondelle de contact
31	5000332	0295 000 0170	1	A5,3 ISO 7089		Scheibe	Washer	Rondelle
32	5004331	0295 899 0225	1		LWA 101 dB	Aufkleber	Sticker	Autocollant
33	5000340	0286 570 0069	5	B6,4 ISO 7090		Scheibe	Washer	Rondelle
34	5008767	0282 650 9039	1	13mm		Kugelhahn	Ball valve	Robinet à boisseau sphérique
35	5008788	0289 400 9105	1		Sicherheitspiktogramm	Aufkleber	Sticker	Autocollant
36	5008768	0282 650 9004	1		Warnung vor Riemetrieb	Aufkleber	Sticker	Autocollant
37	5002527	0295 899 0009	1		Pfeil	Aufkleber	Sticker	Autocollant
38	5000591	0295 000 0733	2	M12x25 ISO 4762		Schraube	Screw	Vis
39	5000340	0286 570 0069	4	B6,4 ISO 7090		Scheibe	Washer	Rondelle
40	5000707	0282 170 0067	4	M6x10 ISO 4017		Schraube	Screw	Vis
41	5000721	0282 150 0035	1	M8x20 ISO 4017		Schraube	Screw	Vis
42	5000361	0282 150 0036	1	A8 DIN 127		Federring	Spring washer	Rondelle élastique bombée
43	5000722	0282 250 0073	1	M8x25 ISO 4017		Schraube	Screw	Vis

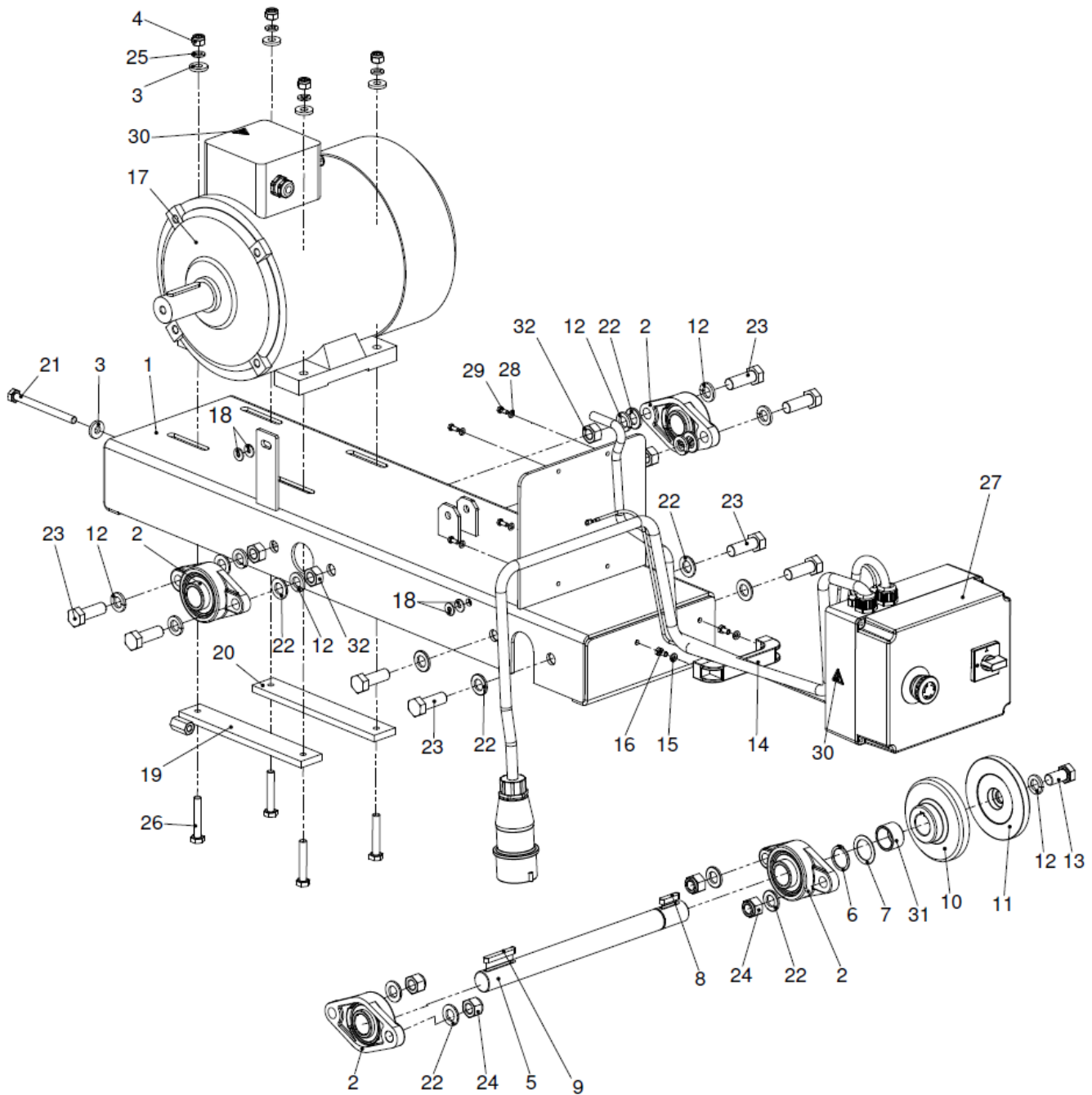

Pos.	K.-Art.-Nr.	Art.-Nr.	Qty.	Norm	Info	Bezeichnung	Description	Désignation
1	5007687	0282 650 9071	1			Motorträger	Cutting head	Support du moteur
2	5004198	0282 250 0022	4	UCFL 206-D30		Flanschlager	Bearing	Flasque bride
3	5001105	-	5	A10,5 DIN 7349		Scheibe	Washer	Rondelle
4	5000857	0286 570 0052	4	M10 DIN6923		Mutter	Nut	Écrou
5	5007634	0282 650 9072	1			Schneidwelle	Blade shaft	Arbre de coupe

Pos.	K.-Art.-Nr.	Art.-Nr.	Qty.	Norm	Info	Bezeichnung	Description	Désignation
6	5000423	9455 621 3320	1	30 x 1,5 DIN 471		Sicherungsring	Circlip	Circlip
7	5000867	0283 100 0678	1	Ø30/Ø42x1 DIN 988		Paßscheibe	Adjusting washer	Rondelle
8	5006777	0282 240 0031	1	A 8 x 7 x 35 DIN 6885		Passfeder	Key	Clavette
9	5001042	0282 240 0029	1	A 8 x 7 x 58 DIN 6885		Passfeder	Key	Clavette
10	5007635	0282 650 9073	1			Flansch	Flange	Flasque
11	5007694	0282 650 9074	1			Flansch	Flange	Flasque
12	5000365	-	9	A16 DIN 127		Federring	Spring washer	Rondelle élastique bombée
13	5000160	0282 240 0040	1	M16x1,5x30 ISO 8676		Schraube	Screw	Vis
14	5002449	0282 650 0141	1			Bügelgriff	Bow-type handle	Poignée en forme d'dérier
15	5000367	-	2	B6 DIN 127		Federring	Spring washer	Rondelle élastique bombée
16	5000708	-	2	M6x12 ISO 4017		Screw	Vis	Screw
17	5007695	0282 650 0187	1			Elektromotor	Electric motor	Moteur électrique
18	5001282	-	4	A6,4 ISO 7093		Scheibe	Washer	Rondelle
19	5007646	0282 650 9075	1			Keilriemen- spanner	V-belt tension device	Dispositif tendeur
20	5007645	-	1	40 x 10 x 250		Distanzstück	Distance piece	Pièce d'écartement
21	5000742	-	1	M10 x120 ISO 4017		Schraube	Screw	Vis
22	5000345	-	12	B17 ISO 7090		Scheibe	Washer	Rondelle
23	5000764	-	8	M16x45 ISO 4017		Schraube	Screw	Vis
24	5000859	-	4	M16 ISO 7040		Mutter	Nut	Écrou
25	5000362	-	4	A10 DIN 127		Federring	Spring washer	Rondelle élastique bombée
26	5000738	-	4	M10x60 ISO 4017		Schraube	Screw	Vis
27	5007613	0282 650 9077	1			Motorschutz- schalter kpl.	Starter assy.	Interrupteur de démarrage
-		0282 650 9085	1			Reihenklemme	Series terminal	Barrette à bornes
-		0282 650 9087	1			Feinsicherung	Microfuse	Fusible
-		0282 650 9084	1			Schütz	Contacteur	Contacteur
-		0282 650 9083	1			Hilfsschalter	Auxiliary contact	Interrupteur auxiliaire
-		0282 650 9086	1			Überlastschutz	Overload protection	Protection de surcharge
28	5000332	-	4	A5,3 ISO 7089		Scheibe	Washer	Rondelle
29	5000704	-	4	M5x12 ISO 4017		Schraube	Screw	Vis
30	5008686	0295 899 0267	2		Vorsicht elek. Spannung	Aufkleber	Sticker	Autocollant
31	5008407	0282 650 9082	1			Buchse	Bush	Douille
32	5000794	0281 045 0051	4	M16 ISO4032		Mutter	Nut	Écrou

9.3 Cutting table

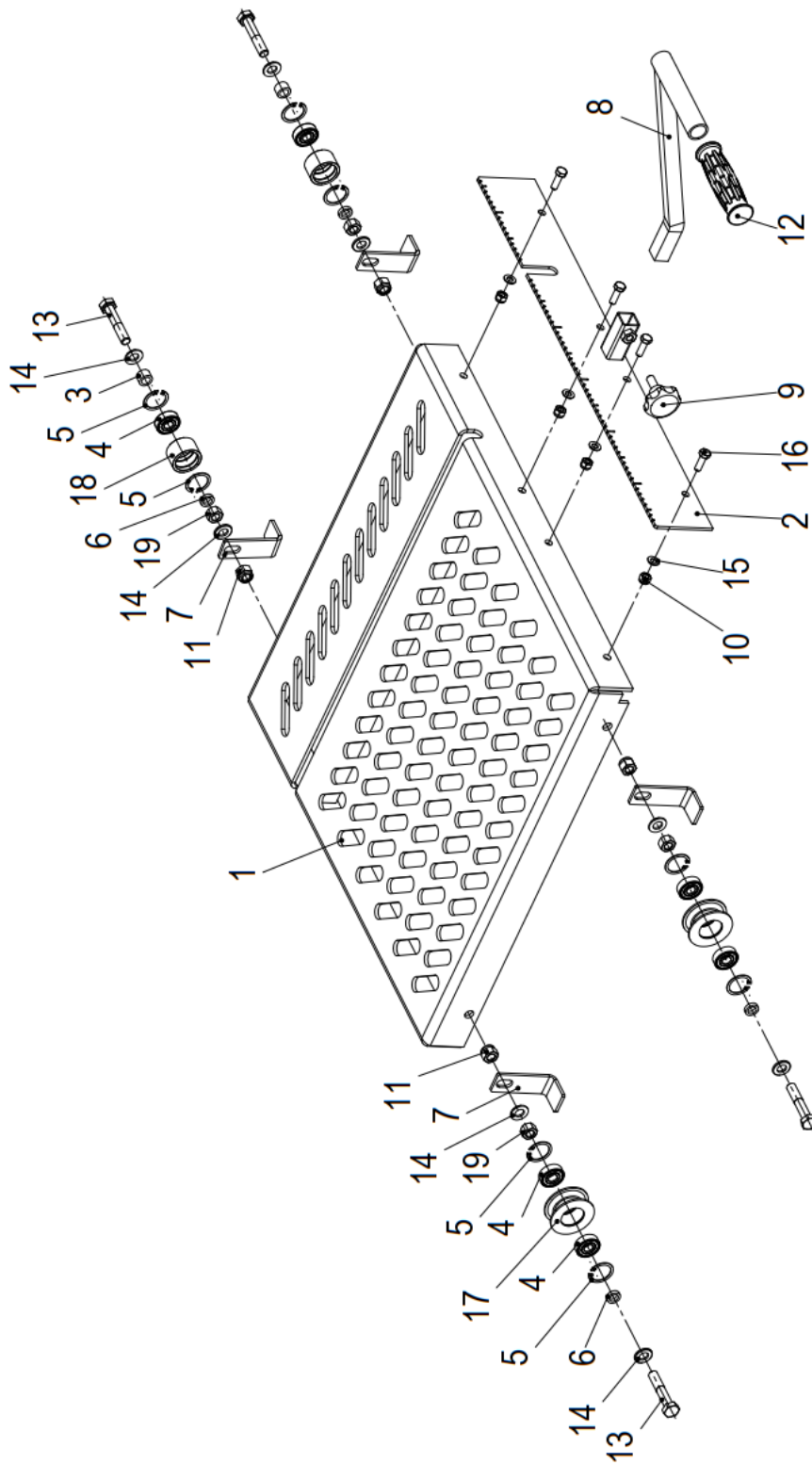

Pos.	K.-Art.-Nr.	Art.-Nr.	Qty.	Norm	Info	Bezeichnung	Description	Désignation
1	6002288	0282 650 9015	1			Schnittguttisch	Cutting table	Table de travail
2	5007668	0282 650 9011	1			Anschlag	Stop	Arrêt
3	5005190	0281 350 0115	2			Distanzbuchse Schnittguttisch	Spacer bushing	Douille
4	5000484	0281 045 0020	6	6201-2RS DIN 625		Lager	Ball bearing	Roulement à billes
5	5000436	0281 045 0018	8	32 x 1,2 DIN 472		Sicherungsring	Circlip	Circlip
6	5007670	0282 650 9019	4	Ø18/Ø12x4,5		Distanzbuchse	Spacer bushing	Douille
7	4003159	0282 650 0115	4			Ausfallsicherung	Fail safe	Arrêt de sécurité
8	4003276	0282 650 0117	1			Führungsgriff	Handle	Poignée
9	5001554	0281 045 0028	1	M10x25		Sterngriff- schraube	Star grip	Poignée-étoile
10	5000856	0282 065 0005	4	M8 ISO 7040		Mutter	Nut	Ecrou
11	5000858	0285 300 0015	4	M12 ISO 7040		Mutter	Nut	Ecrou
12	5001372	0285 300 0044	1			Griff	Handle	Poignée
13	5000676	0281 045 0017	4	M12x65 ISO 4014		Schraube	Screw	Vis
14	5000343	0282 250 0105	8	B13 ISO 7090		Scheibe	Washer	Rondelle
15	5000341	0282 250 0006	4	B8,4 ISO 7090		Scheibe	Washer	Rondelle
16	5000722	0282 250 0073	4	M8x25 ISO 4017		Schraube	Screw	Vis
17	4001591	0281 350 0125	2			Führungsrolle	Guiding roller	Roue de guidage
18	4001565	0281 350 0130	2			Stützrolle	Supporting roller	Galet support
19	5000793	0295 000 0178	4	M12 ISO 4032		Mutter	Nut	Ecrou

10. Optional accessory

10.1 Forklift guidance

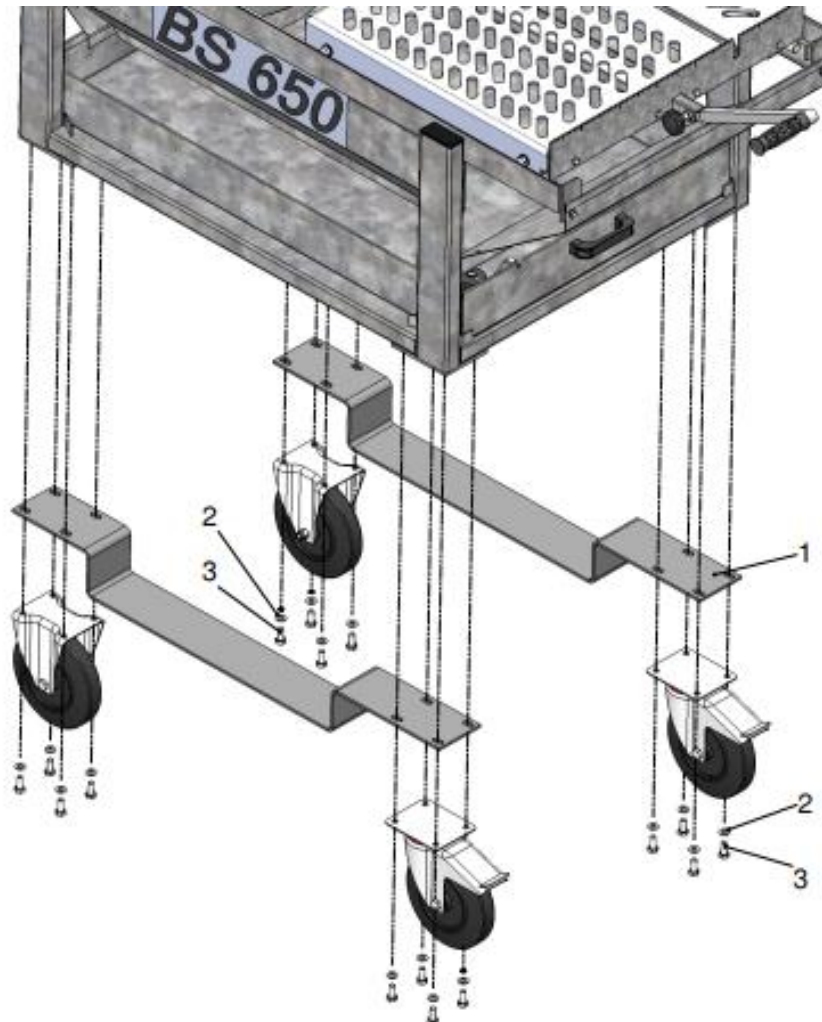

Pos.	K.-Art.-Nr.	Art.-Nr.	Qty.	Norm	Info	Bezeichnung	Description	Désignation
-	-	0282 650 9035	1		Pos. 1-3	Staplerführung kpl.	Forklift guidance complete	Kit pour transport par chariot élévateur
1	5007657	0276 650 9014	2			Staplerführung	Forklift guidance	Kit manutention chariot élévateurs
2	5000342	0286 570 0047	16	B10,5 ISO 7090		Scheibe	Washer	Rondelle
3	5001334	0295 000 0179	16	M10x25 ISO 4017		Schraube	Screw	Vis

10.2 Back square

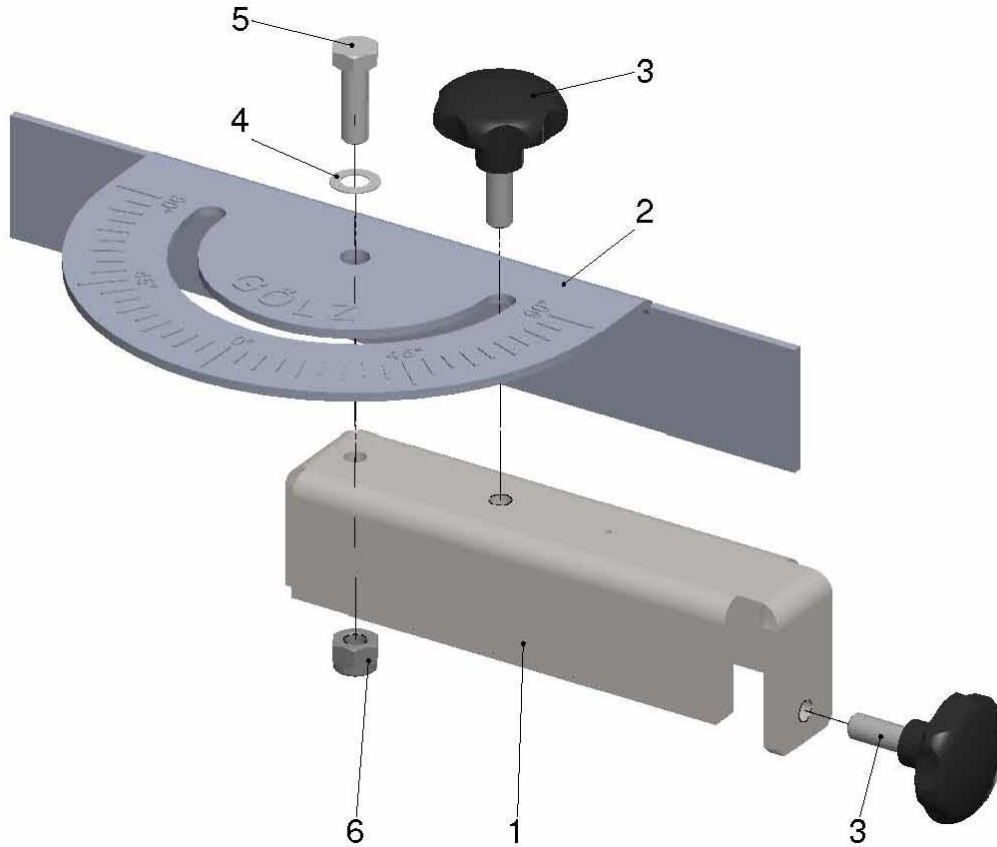

Pos.	K.-Art.-Nr.	Art.-Nr.	Qty.	Norm	Info	Bezeichnung	Description	Désignation
-	5005527	0282 650 0135	1		Pos. 1-6	Anschlagwinkel kpl.	Back square complete	Équerre complète
1	3003862	0281 350 0011	1			Aufnahme	Acceptance	Levé
2	2003898	0281 350 0012	1			Anschlagwinkel	Back square	Équerre
3	5001015	0282 190 0224	2	M8x20 DIN 6336		Sterngriff-schraube	Star grip screw	Poignée-étoile
4	5000371	-	1	A8 DIN 137		Federscheibe	Spring washer	Disque de ressort
5	5000722	-	1	M8x25 ISO 4017		Schraube	Screw	Vis
6	5000856	-	1	M8 ISO 7040		Mutter	Nut	Ecrou

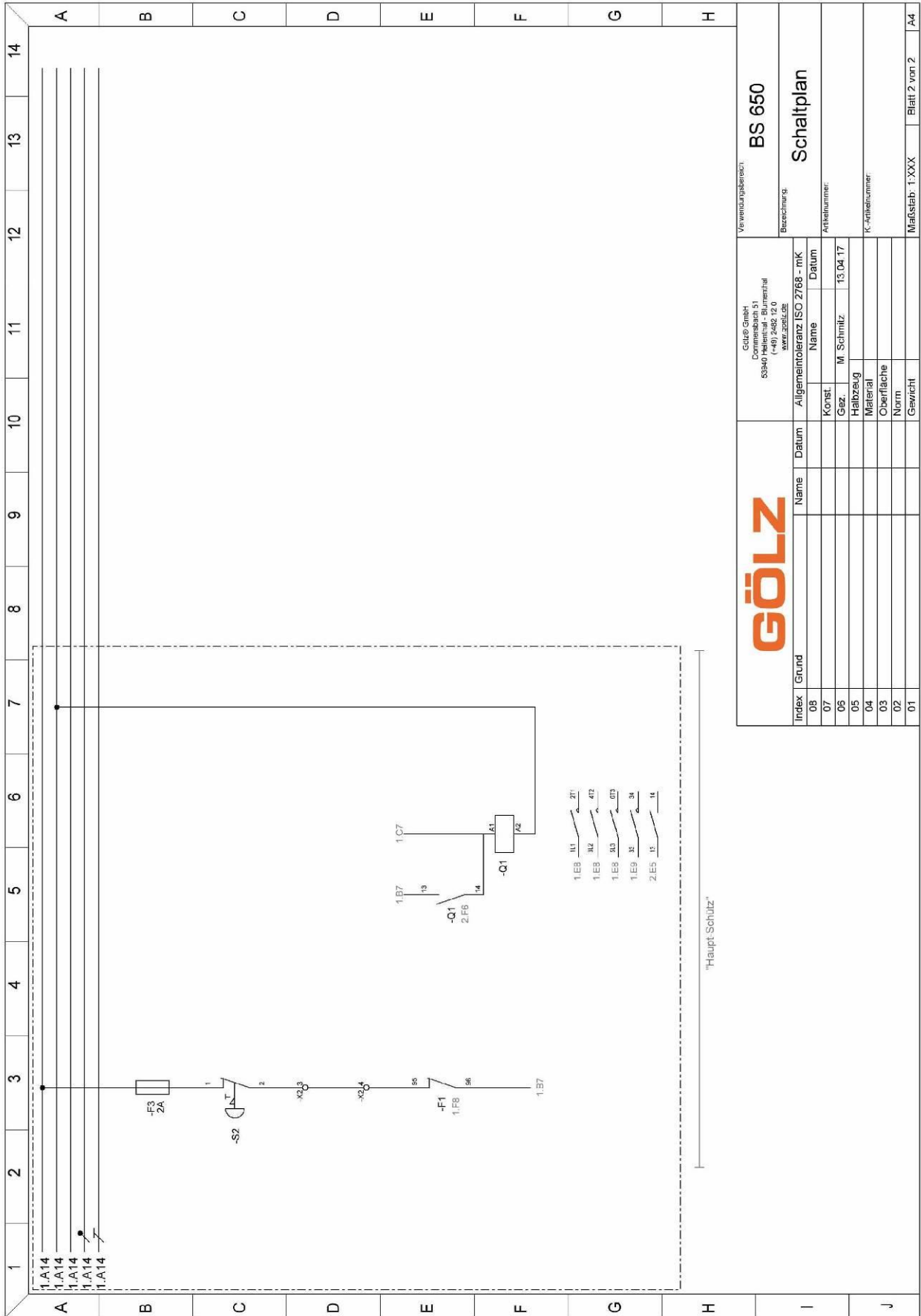

Verwendungsbezeichnung:		BS 650	
Bezeichnung:		Schaltplan	
Götz® GmbH, Commerzbach 31 53340 Hellenthal - Büllenthal (0225) 924-0 www.golz.de		Arbeitsnummer:	
Allgemeintoleranz ISO 2768 - mK		Datum	
Index	Grund	Name	Datum
08			
07		Konst.	
05		Gez.	M. Schmitz
05		Halbzeug	13.04.17
04		Material	
03		Oberfläche	
02		Norm	
01		Gewicht	
		K-Teilnummer:	
		Maßstab: 1:XXX	
		Blatt 2 von 2	
		A4	