

DATA SHEET

OMI97-24 TECH 110v

S-A8CA3C4FPS567



UNIT DIMENSIONS



PACKAGE DIMENSIONS

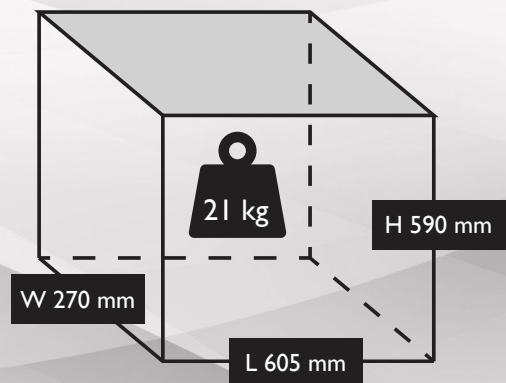

TECHNICAL DATA

	Max. Pressure	8 Bar / 116 PSI
	Power	1.5 HP / 1.1 kW
	Capacity (displacement)	7.1 CFM / 200 L/Min
	Voltage	110V / 50 Hz
	Supply	3kVA
	Pump	OMI97 (A80000B)
	dB(A)	78
	Dimensions L x W x H (unit)	595 x 260 x 580 mm

	Dimensions L x W x H (boxed)	605 x 270 x 590 mm
	Weight	21 kgs
	Motor Speed	2880 RPM
	Oil Capacity	N/A
	Receiver Size	24 Ltr
	Head Bolt Torque	11 Nm
	Cable Length	2 Mtr
	Pump Speed	2880 RPM
	Outlet Thread Size	1/2" G / Series 25 Coupling



E & OE
Images shown are for illustration and may vary from the actual product

Unit 5, Tower Estate,
Warpsgrove Lane,
Chalgrove,
Oxon,
OX44 7XZ

Tel: +44(0)1865 892620
Fax: +44(0)1844 390955

sales@fps-compressors.co.uk
www.fps-compressors.co.uk



DATA SHEET

OMI97

A8000B

OMI97-24 TECH 110v (S-A8CA3C4FPS567)

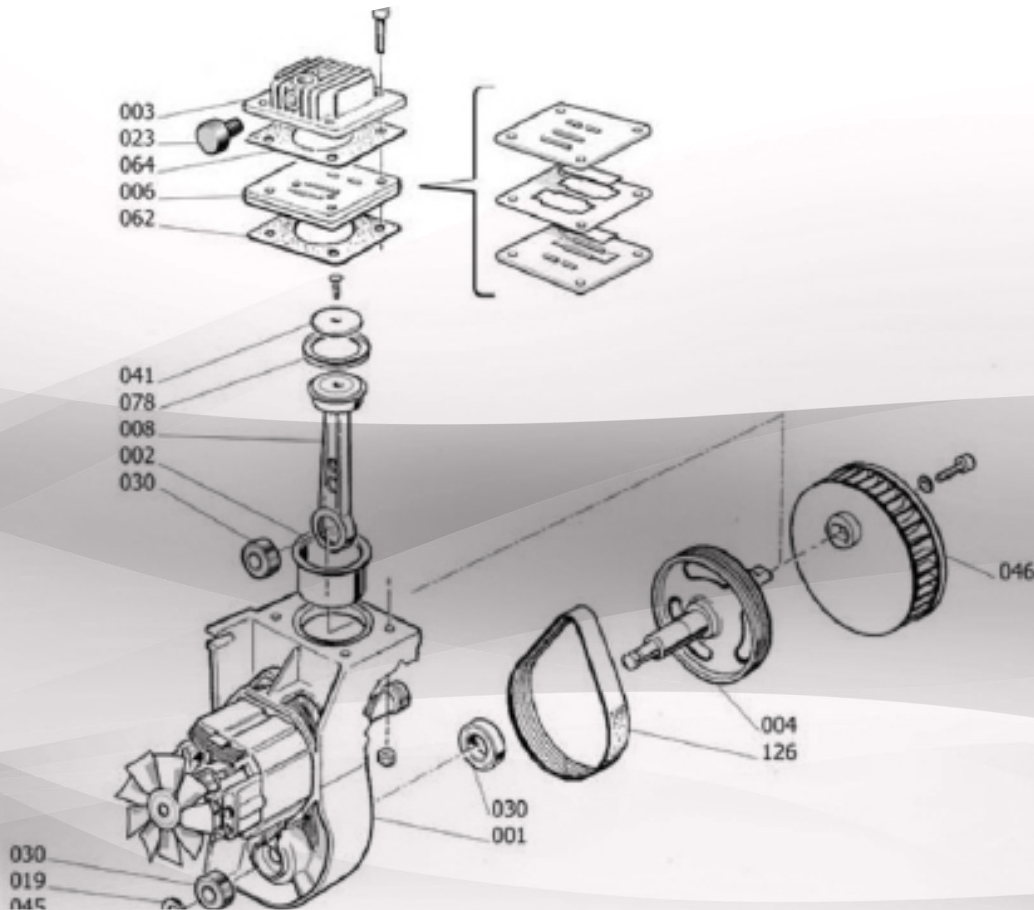
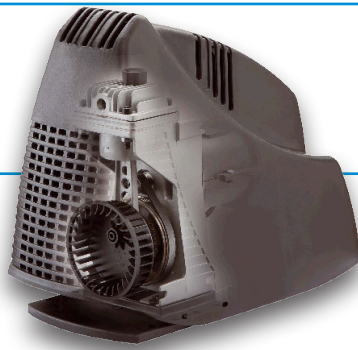

COMPONENTS (see drawing above)

Position	Part No.	Description
6	S-9415091	Valve Plate
8	S-A810100	Con Rod complete
2	S-A731040	Cylinder
3	S-9415894	Head
62	S-A650300	Cylinder plate gasket
64	S-9415052	Plate head gasket
23	S-9416634	Air Filter
126	S-9075317	V Belt
46	S-9038320	Fan

OTHER SERVICE PARTS

Part No.	Description
S-PK-OMI97	Service Kit
S-9412842	NRV
S-9063048	Pressure Switch
LUB-PIST-ILT	Lubricant
N/A	Capacitor



E & OE
Images shown are for illustration and may vary from the actual product

Unit 5, Tower Estate,
Warpsgrove Lane,
Chalgrove,
Oxon,
OX44 7XZ

Tel: +44(0)1865 892620
Fax: +44(0)1844 390955

sales@fps-compressors.co.uk
www.fps-compressors.co.uk

