

Weatherguard Site

Product Codes: **WGS220Y, WGS220Y-E, WGS420Y, WGS420Y-E, WGS525Y, WGS525Y-E, WGS550Y, WGS550Y-E**

Safety Warning



- The installation should be carried out by a qualified electrician in compliance with the current edition of the IEE Wiring Regulations.
- Prior to installation, carry out the necessary risk assessment considering the people who could be at risk, the level of risk and the precautions required to control the risk
- Ensure that the circuit supply is isolated either by the circuit supply fuse being removed or the applicable circuit breaker being turned off before installation or any maintenance.
- Check the total load on the circuit ensuring the luminaire does not exceed the rating of the circuit cable, fuse or circuit breaker.
- Long-term use and voltage fluctuations can reduce the life span of the fitting.
- If the fitting incorporates control gear, ensure careful sizing to avoid instances of nuisance tripping of the protective device used in the installation.
- Follow the provided installation instructions, using the fixings supplied or recommended.
- Keep out of reach of children.



Specification

Box Contents -

1 x Weatherguard Site, 1 x Accessory Pack

Dimensions:	WGS220Y/-E: L: 664 x W: 103 x D: 78mm WGS420Y/-E: L: 664 x W: 72 x D: 78mm WGS525Y/-E: L: 1562 x W: 72 x D: 78mm WGS550Y/-E: L: 1562 x W: 103 x D: 78mm
Material:	Body & Diffuser - Polycarbonate, Gear Tray - Steel
Working Temperature:	Standard: -25°C - 40°C Emergency: 0°C - 40°C
Included:	Accessory pack with Compression Gland, Blind Grommet, 2 x Mounting Brackets, 2 x Hanging Adaptors, 4 x Screws & Expansion Plugs

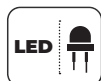
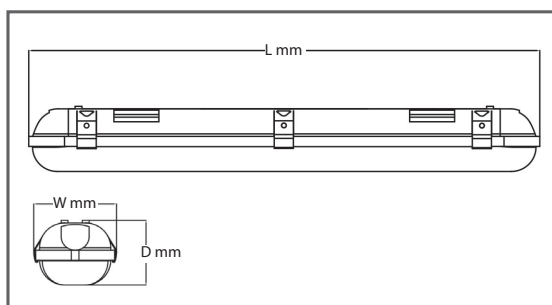

*Batteries 2 year guarantee

MAXIMUM FITTINGS PER CIRCUIT

Automatic Circuit Breaker Type:	B6	B10	B13	B16	B20	C10	C13	C16	C20
Rated Current:	6A	10A	13A	16A	20A	10A	13A	16A	20A
Cable (mm):	1.5	1.5	1.5	1.5	2.5	1.5	1.5	1.5	2.5
WGS220Y/-E & WGS420Y/-E:	14	56	56	56	98	56	56	56	98
WGS525Y/-E:	10	42	42	42	77	42	42	42	77
WGS550Y/-E:	12	22	22	22	37	22	22	22	37

Installation Instructions

- Mark the locations of where the fitting is to be placed, then drill 6mm holes for the brackets.
- Insert the expansion plug into the holes drilled and fix the brackets using the screws.
- Clip the body of the fitting to the brackets in the correct positions and insert the supply cable through the compression gland.
- Raise the LED tray to the body and connect the supply cable into the terminal block on the back of the LED tray, tighten the compression gland and then clip the LED tray into the body.
- Place the diffuser into the body and ensure all the diffuser clips are clipped into place and seated correctly.
- Turn the power back on to the circuit being worked on and make sure the fitting is working correctly.

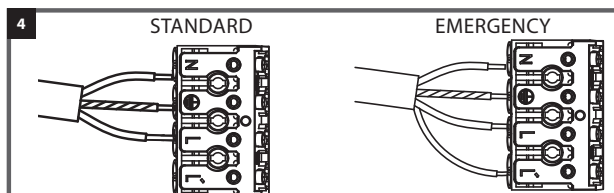
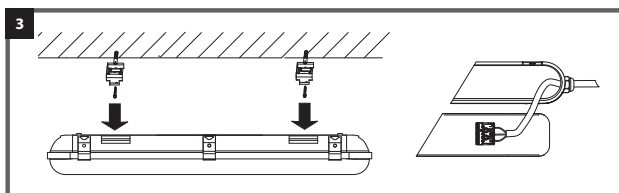

Guarantee

This product is guaranteed for a period of 3 years (Batteries 2 years) from the date of purchase. The guarantee is invalid in the case of improper use, tampering, removal of the Q.C. date label, installation in an improper working environment or installation not according to the current edition of the I.E.E. Wiring Regulations (BS7671). The guarantee is also invalidated if the luminaire has been insulation tested. Should this product fail during the guarantee period it will be replaced free of charge, subject to correct installation and return of the faulty unit. We do not accept responsibility for any installation costs associated with the replacement of this product. Your statutory rights are not affected. We reserve the right to alter specifications without prior notice.

Maintenance

- This fitting will require routine cleaning if used in adverse (dust, paint, welding, oils etc) environments. Do not use solvents, aggressive detergents or abrasives.
- The light source & driver in this luminaire can be quickly and easily replaced at end of life. This should be carried out by a competent person. Contact Red Arrow for details of replacements.

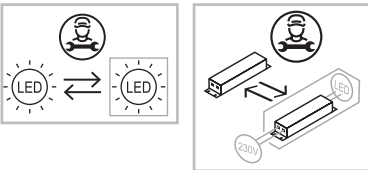

- When this fitting comes to the end of its life or you choose to replace it, please do not dispose of it with your normal household waste. Please recycle where the facilities exist, check with your local authority for suitable options.

INS/SITE/0001/WGS/V6