

YOUNGMAN

INNOVATIVE WORK AT HEIGHT SOLUTIONS

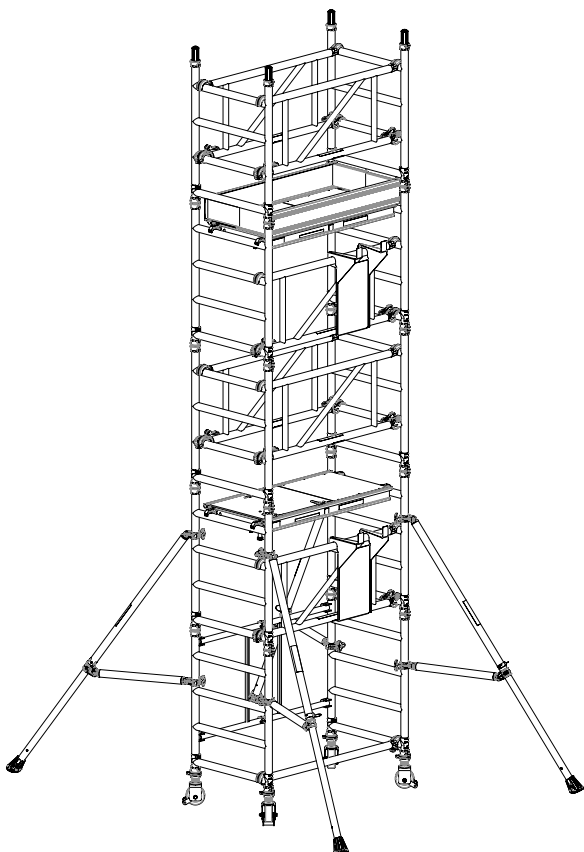

BoSS SOLO 700

One Man Aluminium Tower

EN1004-3-4/4

EN1298-IM-EN

3T - Through the Trap Door

USER GUIDE

Edition August 2013



Contents

Safety First	2
Component Diagram	7
Quantity Schedules	9
Stabalisers	10
Build Method	11

Safety First

INTRODUCTION

Please read this guide carefully. Please note that diagrams are for illustrative purposes only.

User guides are also available to download from our website at youngmangroup.com

BoSS mobile aluminium towers are light-weight scaffold towers used throughout the building and construction industry for both indoor and outdoor access solutions where a stable and secure platform is required. Ideal for maintenance and installation work or short term access, the highly versatile towers provide a strong working platform at a variety of heights.

The law requires that personnel erecting, dismantling, altering or inspecting towers must be competent. Any person erecting the product described in this user guide must have a copy of this guide. For further information on the use of mobile access and working towers consult the PASMA operator's code of practice or visit our website at youngmangroup.com

If you need further information, additional guides or any other help with this product, please contact Youngman on +44 (0)1621 745900 or email sales@youngmangroup.com

Safety First

SAFE USE

- Check that all components are on site, undamaged and that they are functioning correctly – (refer to Checklist and Quantity Schedules). Damaged or incorrect components must never be used and segregated for replacement, repair or destruction.
- Ensure the ground on which the mobile access tower is to be erected and moved is capable of supporting the tower.
- The safe working load is 275 kgs (675lbs), per platform level, uniformly distributed up to a maximum of 550kgs (1213lbs), per tower.
- Adjustable legs should only be used for levelling.
- Do not use ladders, steps, boxes or similar, to gain additional working height.
- Mobile Access Towers are not designed to be lifted or suspended.
- Youngman Group strongly advises against the mixing of tower components because of the potential safety risks for users, and their inability to rely upon the manufacturers Product Liability Insurance in the event of an accident occurring as a result of mixing components from different manufacturers. For more information visit www.youngmangroup.com/about/mix-match-components
- It is recommended that towers should be tied to a solid structure when left unattended.

LIFTING OF INDIVIDUAL TOWER COMPONENTS

- Tower components should be lifted using the BoSS SOLO 700 assembly bracket.
- Raising and lowering components, tools and/or materials by rope should be conducted within the tower base (i.e. within the area bounded by the stabilisers). Ensure that the safe working load of the supporting decks and the tower structure is not exceeded.

Safety First

MOVING THE TOWER

- Towers should be moved with caution.
- Before moving, check the suitability of the intended route to ensure there are no obstructions, both at ground level and overhead. Wind conditions must also be considered.
- People and materials must be removed and the height of the tower reduced to 4.0m.
- Finally, the stabilisers should be left in position and raised no more than 25mm from the ground.
- The tower must only be moved by applying manual effort at, or near, the base of the tower and you should ensure there are sufficient operatives on hand to control the movement of the structure.
- After moving and before use, check the tower is still correct and complete. Use a spirit level to ensure that it is vertical and level, then adjust the legs as required.
- Do not move the tower in wind speeds over 7.7 metres per second (17mph).

MAINTENANCE - STORAGE - TRANSPORT

- All components and their parts should be regularly inspected to identify damage, particularly to joints. Lost or broken parts should be replaced and any tubing with indentation greater than 5mm should not be used and put to one side for repair by the manufacturer. Adjustable leg threads should be cleaned and lightly lubricated to keep them free running.
- Brace claws, frame interlock clips, trapdoor latches, camlocks, claw mechanisms and platform windlocks should be regularly checked to ensure they lock correctly.
- Refer to the BoSS Inspection Manual and poster for detailed inspection and maintenance advice: youngmangroup.com/products/access-towers
- Components should be stored in clean, dry conditions with due care to prevent damage.
- Ensure components are not damaged by excessive strapping forces when transported.

Safety First

PREPARATION AND INSPECTION

- Inspect the equipment before use to ensure that it is not damaged and that it functions properly. Damaged, incorrect or incompatible components must not be used.

DURING ASSEMBLY, USE AND DISMANTLING

- Complete towers, in accordance with EN1004, should be stable in a free standing condition in a wind speed that equates to 28mph or Beaufort force 6. If the wind speed should exceed 17mph you should cease work upon the tower. If the wind speed is expected to reach 25mph the tower should be tied into a rigid structure. If it is expected to reach 40mph the tower should be dismantled.
- The effect of on-site wind conditions must be considered prior to the assembly of a tower.
- Sheets, tarpaulins, cladding or similar, must not be attached to the tower as these will significantly increase any side loads from wind and will potentially make the tower unstable.
- Wind conditions from funnelling effects, such as open ended buildings, hangers or unclad buildings, must also be considered prior to use as these wind effects can be much greater.

Wind Description	Beaufort Scale	Beaufort No.	Speed in m.p.h	Speed in m/sec
Medium Breeze	Raises dust and loose paper, twigs snap off	4	8-12	4-6
Strong Breeze	Large branches in motion, telegraph wires whistle	6	25-31	11-14
Gale Force	Walking is difficult	8	39-46	17-21

- Excessive side loads from working on the tower, i.e. through drilling or pulling, may also make a tower unstable. The maximum allowable side load on a tower is 20kg.
- Do not abuse equipment. Damaged, incorrect or incompatible components should not be used.

Safety First

TIES

- You should tie in towers of all heights wherever possible, as it is safe practice to do so. However, where towers are left unattended or are to be located in particularly exposed conditions, wind forces will almost certainly affect stability. In these circumstances ensure that the tower is adequately tied in or restrained from blowing over and that the platforms are securely fixed, or alternatively the tower dismantled.
- For further information on tying-in a tower consult the PASMA Technical/Safety Guidance Note:
“Tying Mobile Access Towers”
www.youngmangroup.com/products/access-towers



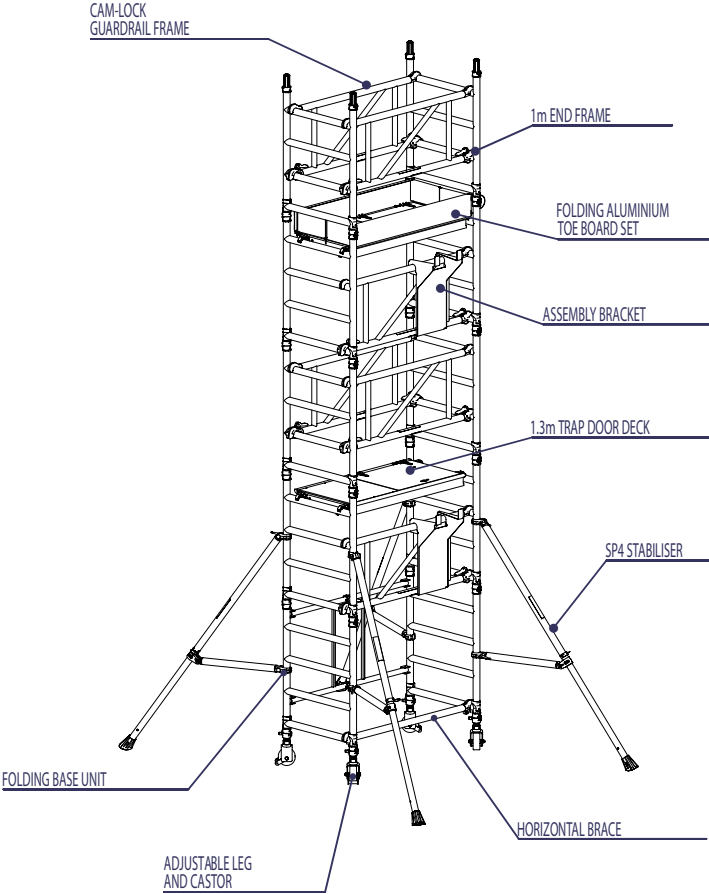

Safety First











Safety Checklist

Mobile Towers - 3T Method

PRE-ASSEMBLY CHECKLIST

- Ensure all components are present (see quantity schedule on page 9) 
- Inspect components prior to assembly 
- Ensure all brace claws, cam-locks and adjustable legs operate correctly 
- Ensure castors rotate freely and brakes lock 
- Full inspection guidance can be found here at youngmangroup.com/products/access-towers 

PRE-USE CHECKLIST

- Inspect tower prior to use 
- Tower is vertical and level, using a spirit level, and adjust legs if necessary 
- Castors are locked 
- Correct stabilisers are fitted correctly 
- Platforms are fitted correctly and windlocks engaged 
- Toeboards are fitted correctly 
- Guardrails are fitted correctly, see illustrations below 
- Re-inspect the tower every 7 days or less 



Quantity Schedule

BoSS Solo 700 - 1.3m x 0.7m				
3T Method		Internal or external use		
Component	Working Height (m)	4.2	5.2	6.2
	Platform Height (m)	2.2	3.2	4.2
Castor		4	4	4
Adjustable Leg		4	4	4
4 Rung End Frame (1.0m high x 0.7m wide)		4	6	8
Folding Base Unit		1	1	1
1.3m CamLock Guardrail Frame		3	5	6
1.3m Trap Door Deck		1	2	2
1.3m Horizontal Brace		1	1	1
Aluminium Folding Toe Board		1	1	1
Assembly Bracket		2	2	2
SP4 Telescopic Stabiliser		4	4	4
Total Self Weight of Tower (Kg)		93	121	134

NUMBER OF WORKING PLATFORMS ALLOWED

The MAXIMUM SAFE WORKING LOAD (the combined weight of the users, tools and materials) that maybe placed on the tower is 550kg.

PLATFORM LOADING

The maximum safe working load (the combined weight of the users, tools and materials) that may be placed on a platform is 275kg. This must be evenly distributed over the whole platform level.

The quantity schedules shown in this user guide will enable the tower to be built safely and therefore comply with the requirements of the 'Work at Height Regulations'. Folding toe boards will need to be added if any levels are used as working platforms or for storage of materials.

This tower system has been developed in accordance with EN1004 for single person use. If the tower is to be used with two people, SP10's stabiliser must be fitted in place of SP4 stabilisers.

Quantity Schedule

STABILISERS

Stabalisers shall always be fitted when specified.

To improve stability, larger stabilisers can be used at a lower level than shown in the quantity schedules.

Attach one stabiliser to each corner of the tower as shown. Ensure stabiliser feet are equally spaced to form a square.

SP4 and SP10 telescopic stabilisers must always be fully extended.

Position the lower clamp so that the lower arm is as close to horizontal as possible. Adjust the position of the top clamp to ensure the stabiliser foot is in contact with the ground. Ensure clamps are secure.

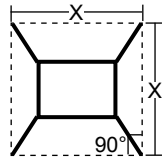

When moving the tower, adjust the top clamps or the telescopic leg, to lift the four stabiliser feet a maximum of 25mm off the ground and then unlock the castor brakes. After moving ensure all four stabiliser feet are repositioned in firm contact with the ground.

Free Standing Tower

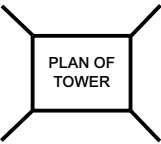

Against a Wall

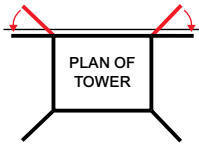

In a Corner

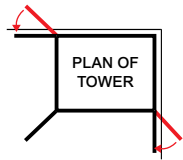

Build Method

When Building a BoSS Tower:

- To comply with the 'Work at Height Regulations' we show assembly procedures with platforms every 2 metres in height and the locating of guardrails in advance of climbing onto a platform to increase safety and reduce the risk of a fall.
- Never stand on an unguarded platform positioned above the first rung of a tower. If your risk assessment shows it necessary, you may also need to guardrail platforms at this level.

The procedure illustrated shows a 6.2m working height tower.

The BoSS SOLO 700 system has been developed so that a single person can safely build the tower to a platform height of 4.2m.

- 1** Insert castor into adjustable leg, apply brake by pushing the lever down, release frame interlock clips and fit the leg and castor assembly into a 1m base frame. Repeat with the remaining legs and castors. Adjustable legs should only be used for levelling.

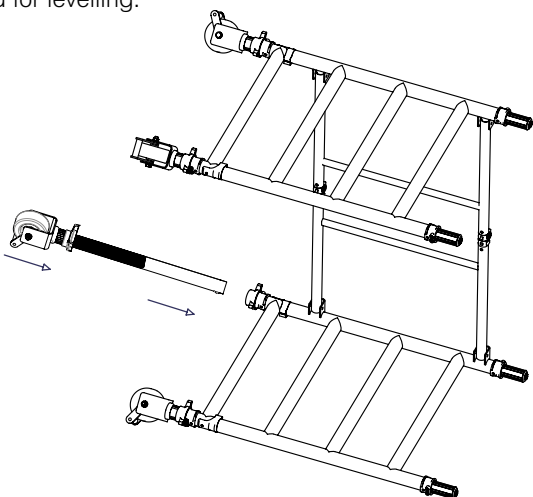

Build Method

2 Folding base method:

- Release brakes on castors at one end frame until the locks will engage on the rear folding frame
- Ensure both hinges positively lock into position
- Engage brakes on second frame

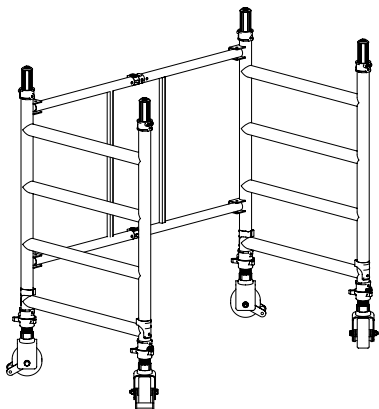

- ## 3
- Locate the horizontal brace on the lowest rung with the hooks facing downwards - check the brace is correctly locked on the tube at both ends. Check the base unit is square and level using a spirit level. Adjust legs only to level and not to gain additional height.

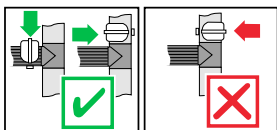
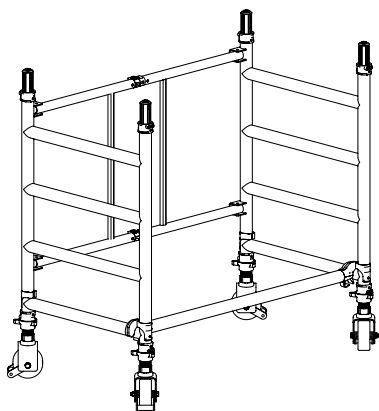

Build Method

4 **STEP 1:** Connect two, 4 rung frames together. Check the interlock clips are engaged and add onto the base unit, repeat for the other side.

STEP 2: Position 1 BoSS Cam-Lock Guardrail unit. The top hooks should locate on the 7th rung from base level.

STEP 3: Engage Cam-Locks as shown to lock guardrail unit in position.

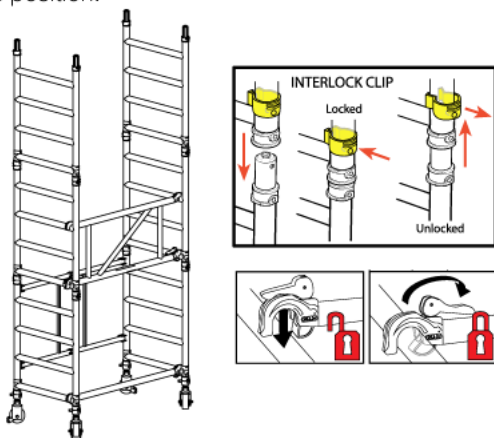

5 Fit stabilisers to tower before extending telescopic leg. Position top clamp above rung 6, second clamp locates above rung 2. Extend telescopic leg by removing the interlock clip - slide the leg out until the leg reaches the ground. Rotate the leg until the interlock clip holes line up. Lock the leg by using the interlock clip and adjust the stabiliser to ensure the stabilisers are engaged.

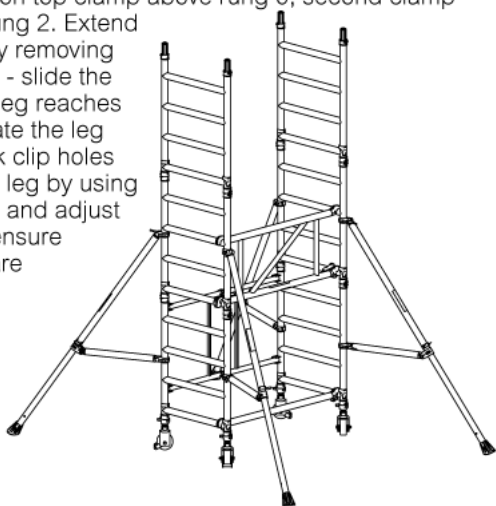
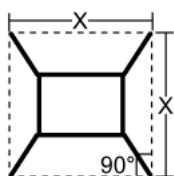

Build Method

6 From the ground level, position a trapdoor deck on rung 8. Engage the windlocks. Locate Assembly Bracket No. 1 on front face of lowest Cam-Lock Guardrail. Locate the second Assembly Bracket on rung 10 of the end frames.

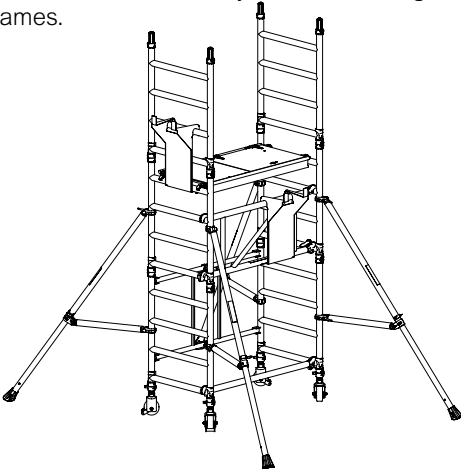

7 Hang in order, 4 Cam-Lock Guardrail units on the front Assembly Bracket and then 1 x Folding Toeboard.

Place the last Cam-Lock Guardrail on the end frame Assembly Bracket No 2. Then hang two pairs of connected 4 rung frames on the end bracket No 2. then hang the second trapdoor deck on the bracket.

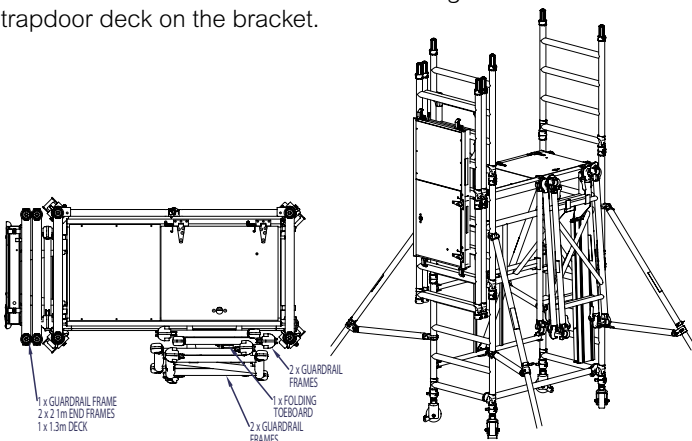

WARNING: ASSEMBLY BRACKETS ARE DESIGNED AND INTENDED ONLY TO AID ASSEMBLY AND DISMANTLING.

Build Method

8 Climb the tower from the inside and from a protected position on the trapdoor, reach to the side bracket and take one Cam-Lock Guardrail. Position the guardrail on the rear of the tower as shown. All guardrails locate on 2nd and 4th rung above the platform deck. Repeat with second Cam-Lock guardrail frame on the front of tower to fully secure platform. Engage and lock camlock claws. **Do not climb on to deck until fully guardrailed.**

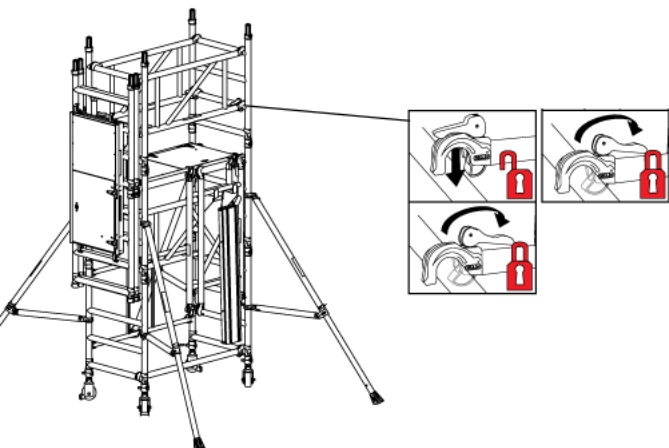

9 Standing up on the protected platform, lift the second trapdoor deck onto the platform, store by the rear guardrail clear of the end frames.

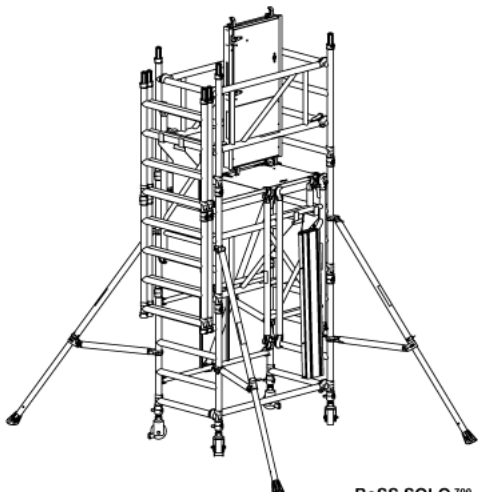

Build Method

10 Add the connected pairs of end frames taking care to engage the locking clips. Add a Cam-Lock Guardrail to rungs 13 & 15 and lock.

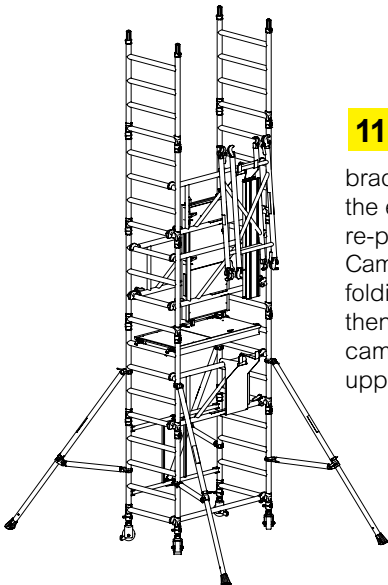
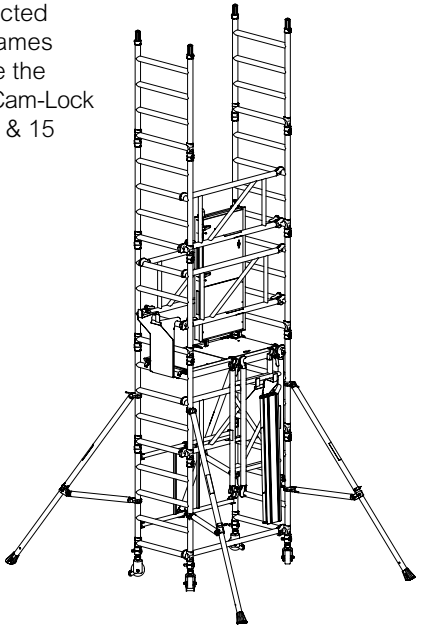

11 Remove the end frame assembly bracket from rung 10 of the end frame and re-position on the top Cam-Lock . Position the folding toe board set and then the remaining two camlock frames on the uppermost bracket.

Build Method

- 12** Place the trap door deck onto the 16th rung of the tower and engage windlocks. Climb the end frame from within and from the protected trap door position, fit the Cam-Lock Guardrails as shown.

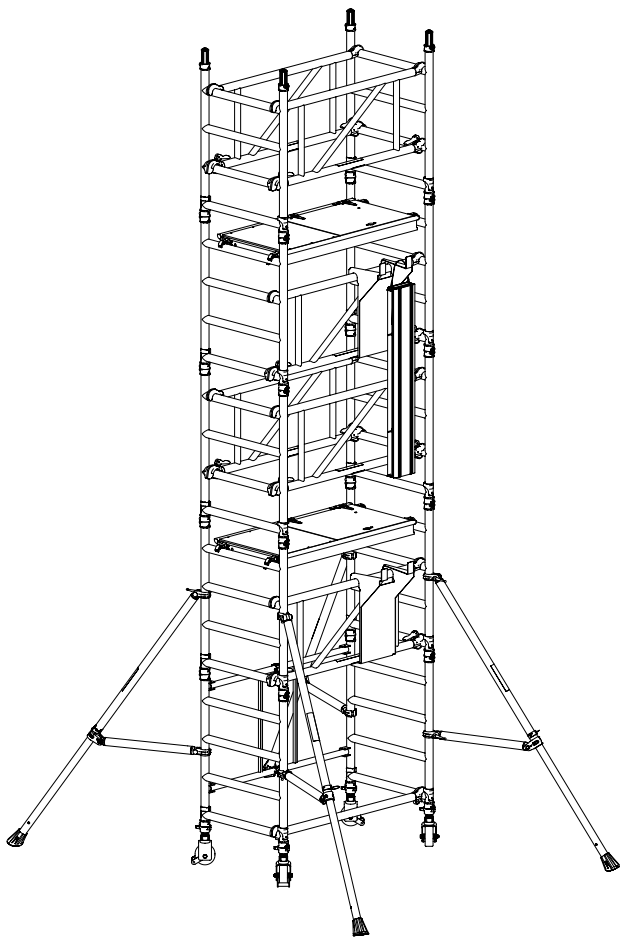

Build Method

- 13** Unclip the storage strap from the Folding Toeboard Set, unfold and fit the toeboard into position on the working platform. Move Assembly Brackets to base of the tower and fit to the lowest rungs of the end frames.

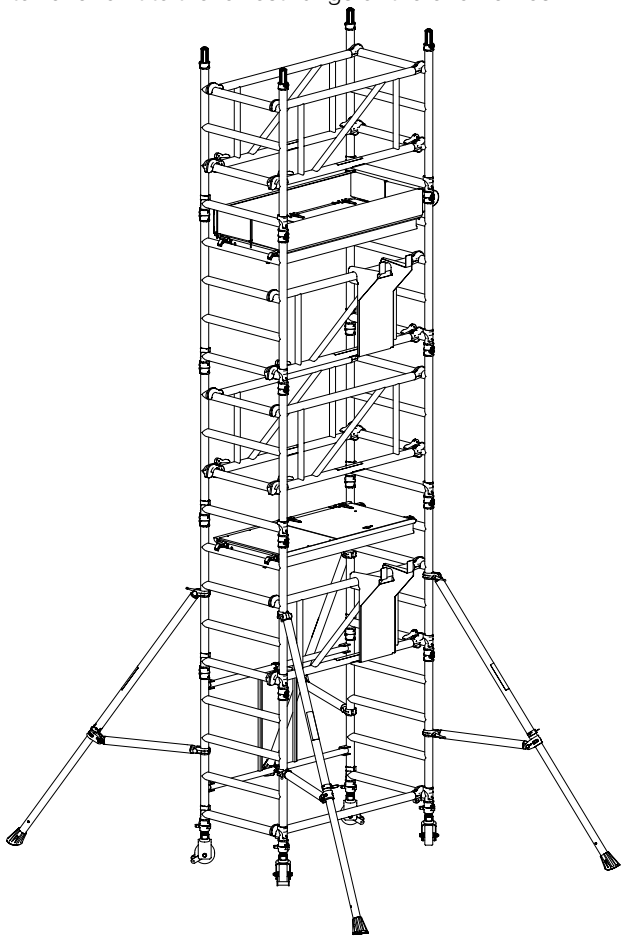

To Dismantle a Boss Tower:

Simply follow the assembly steps in reverse, ensuring that the 3T method is followed.

Build Method

Storage Trolley Assembly:

- 1** Assemble the folding base frame with 1 trap door deck placed on the bottom rung forming the base of the trolley. Lower all adjustable legs as far as possible.

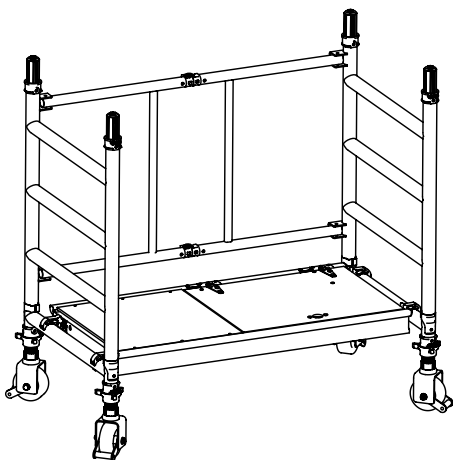

Build Method

2 Fit the folding toeboard set to the trap door deck.

Position the 1.3m horizontal brace on the front upright, just above the 4th rung.

Place the assembly brackets, one at each end, on the inside of the folding base unit end frames.

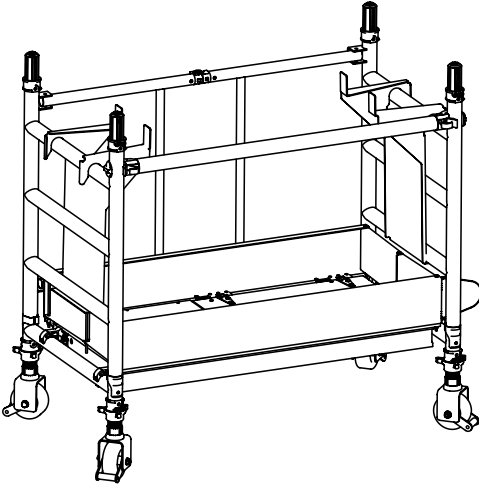

Build Method

- 3** Place the Cam-lock frames, 3 at either end, within the trolley. Ensure the diagonal struts of the Camlock frames fit between the arms of the assembly brackets.

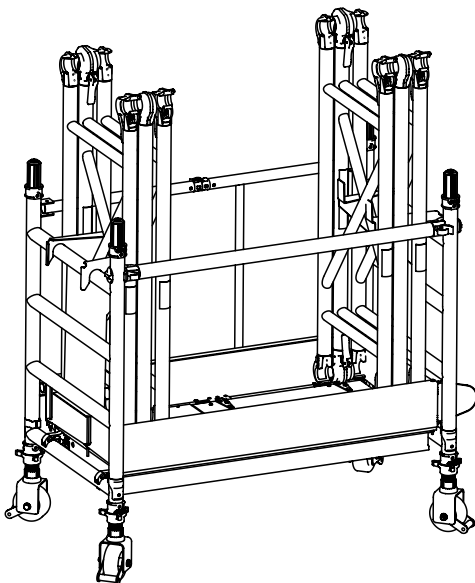

Build Method

4

Place the 1m end frames in the centre of the trolley between the guardrail frames.

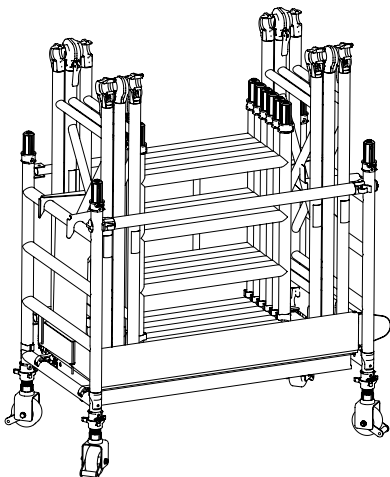

5

Add the final trapdoor deck in front of the 1m end frames. Fit the 4 SP4 stabilisers in front of the trap door deck. The trolley unit is now complete.

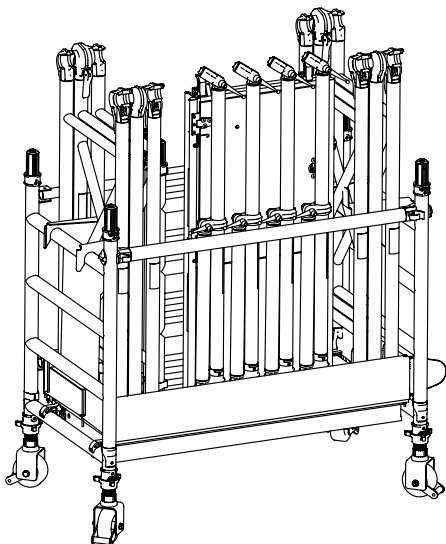

YOUNGMAN

INNOVATIVE **WORK AT HEIGHT** SOLUTIONS



Scan here for:
BoSS SOLO 700 online product page.

For further information regarding
this or any other products or
services please contact :

Youngman are members of:



Youngman Group Ltd

The Causeway, Maldon,
Essex, CM9 4LJ,
United Kingdom

t +44 (0)1621 745900

f +44 (0)1621 859845

e sales@youngmangroup.com



youngmangroup.com