

Clarke[®] CONTRACTOR[®]



30 LITRE MINI CEMENT MIXER

Model CCM50

Part No. 3400850

0907



OPERATING & MAINTENANCE INSTRUCTIONS



Thank you for purchasing this CLARKE Mini Mixer, model CCM50.

Please read this leaflet thoroughly and follow the instructions carefully, in doing so you will ensure the safety of yourself and that of others around you, and you can look forward to the mixer giving you long and satisfactory service.

GUARANTEE

This CLARKE product is guaranteed against faulty manufacture for a period of 12 months from the date of purchase. Please keep your receipt as proof of purchase.

This guarantee is invalid if the product is found to have been abused or tampered with in any way, or not used for the purpose for which it was intended.

Faulty goods should be returned to their place of purchase, no product can be returned to us without prior permission.

This guarantee does not effect your statutory rights.

CONTENTS

Specifications	2
General Safety Precautions	4
Unpacking & Pre-Assembly	5
Assembly	6
Electrical Connections	10
Operation	11
Maintenance	11
Parts List and Diagram	12 - 13
Parts & Service Contacts	15
Declaration of Conformity	15

SPECIFICATIONS

Motor	300W
Power rating	2.9A
Fuse rating	13A
Mixing Capacity	30 Litres
Motor Speed	960RPM
Drum Speed (unloaded)	31RPM
Dimensions -Without Handle (LxWxH)	907x530x845mm
Dimensions - Folded - Without Handle (LxWxH)	907x530x640mm
Guaranteed Sound Power Level (under load)	92dB/LWA
Weight	40kg
Part Number	3400850

GENERAL SAFETY RULES

WARNING:

As with all machinery, there are certain hazards involved with their operation and use. Exercising respect and caution will considerably lessen the risk of personal injury. However, if normal safety precautions are overlooked or ignored, personal injury to the operator or damage to property may result.

- ✓ **ALWAYS READ THE MANUAL.** Become familiar with the entire operating manual. Learn the machine's applications and limitations as well as the specific potential hazards peculiar to it.
- ✓ **ALWAYS CHECK FOR DAMAGED PARTS.** Before use of the machine, it should be checked to ensure that it will operate properly and perform its intended function. Check for any condition that may affect its operation. A part that is damaged should be properly repaired or replaced before the mixer is put into use.
- ✓ **ALWAYS KEEP COVERS AND GUARDS IN PLACE** and in good condition.
- ✓ **ALWAYS REMOVE TOOLS** etc. Form habit of checking to ensure that any tools used for adjusting/repairs, are removed from machine before use.

-
- ✗ **NEVER** operate the machine whilst under the influence of **DRUGS, ALCOHOL** or any **MEDICATION**.
 - ✗ **NEVER STAND ON THE MACHINE.** Injury could occur from a fall.
 - ✗ **NEVER LEAVE MACHINE RUNNING UNATTENDED.** Turn the motor OFF.
 - ✗ **NEVER** put your hands inside the drum when it is rotating. Keep your hands well clear of the rotating drum at all times.
 - ✗ **NEVER WEAR JEWELLERY** or loose clothing that could be snagged by the rotating drum.
 - ✗ **DO NOT LOAD THE DRUM WHEN IT IS STATIONARY.** Always start the motor and ensure the drum is rotating.

 When disposing of this product, do not dispose of with general waste. It must be disposed of according to the laws governing Waste Electrical and Electronic equipment, at a recognised disposal facility.

UNPACKING & PRE-ASSEMBLY CHECK

Remove all components from the packing cases and lay them out neatly so that they may be identified and checked for any possible damage during transit.

Should any component be found to be damaged, please contact your Clarke dealer immediately.

The major components are listed as follows:

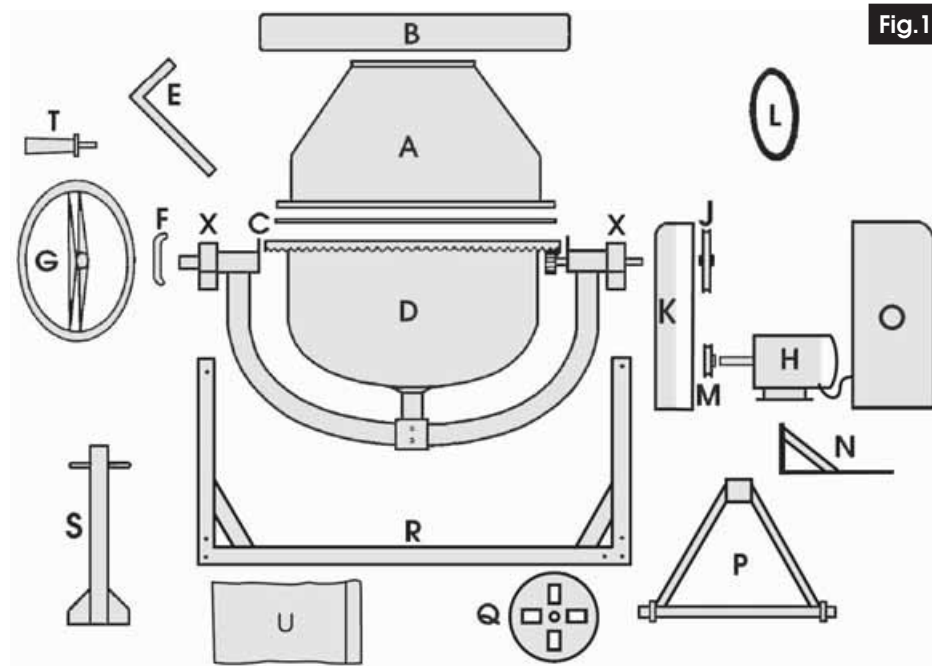

Fig.1

- A. Upper Drum Section
- B. Drum Collar (2 pcs)
- C. Rubber Sealing Ring
- D. Bottom Drum Assembly
- E. Mixing Blades (2 pcs)
- F. Locking Plate
- G. Hand Wheel
- H. Motor with Cover attached
- J. Driven Pulley
- K. Inner Motor Cover
- L. Pulley/Drive Belt

- M. Motor Pulley and Key
 - N. Motor Support Plate
 - O. Outer Cover (attached to motor)
 - P. Axle Assembly
 - Q. Wheel (2 pcs)
 - R. Main Frame
 - S. Leg with handle
 - T. Handle
 - U. Bag of loose parts - Nuts, bolts and washers
- Indicated also are the Bearing Blocks (X)

ELECTRICAL CONNECTIONS

Connect the mains lead to a standard, 230 Volt (50Hz) electrical supply through an approved 13 amp BS 1363 plug, or a suitably fused isolator switch.

WARNING! THIS APPLIANCE MUST BE EARTHED

IMPORTANT: The wires in the mains lead are coloured in accordance with the following code:

Green & Yellow	-	Earth
Blue	-	Neutral
Brown	-	Live

As the colours of the flexible lead of this appliance may not correspond with the coloured markings identifying terminals in your plug proceed as follows:

- Connect GREEN & YELLOW cord to terminal marked with a letter "E" or Earth symbol "⏏" or coloured GREEN or GREEN & YELLOW.
- Connect BROWN cord to terminal marked with a letter "L" or coloured RED.
- Connect BLUE cord to terminal marked with a letter "N" or coloured BLACK.

If this appliance is fitted with a plug which is moulded onto the electric cable (i.e. non-rewireable) please note:

1. The plug must be thrown away if it is cut from the electric cable. There is a danger of electric shock if it is subsequently inserted into a socket outlet.
2. Never use the plug without the fuse cover fitted.
3. When replacing a detachable fuse carrier, ensure the correct replacement is used (as indicated by marking or colour code).
4. Replacement fuse covers can be obtained from your local dealer or most electrical stockists.

FUSE RATING

The fuse in the plug must be replaced with one of the same rating (**13 amps**) and this replacement must be ASTA approved to BS1362.

We strongly recommend that this machine is connected to the mains supply via a Residual Current Device (RCD)

If in any doubt, consult a qualified electrician. DO NOT attempt any repairs yourself.

ASSEMBLY

- NOTE:**
1. Letters in brackets refer to Fig.1
 2. Unless otherwise stated, all nuts, bolts, washers and fixings are supplied.

IMPORTANT

For maximum safety and to ensure the adjustments are carried out correctly, assistance should be employed during the assembly operation.

1. The Stand

- 1.1 Attach the Leg Support to the Frame using an M8 x 60 bolt - A, together with nut, spring and flat washers provided,

Note: This bolt acts as a pivot pin...to be described later.

- 1.2 Secure the leg using an M8x40 bolt - B
Screw on the nut, spring and flat washers provided.
- 1.3 Turn the frame over and attach the Wheel Axle in the same manner.
- 1.4 Slide a cup washer on to each stub axle, followed by a wheel and a second washer. Screw on the castellated nut and lock in place with the split pin provided.

Tighten all nuts securely before righting the stand.

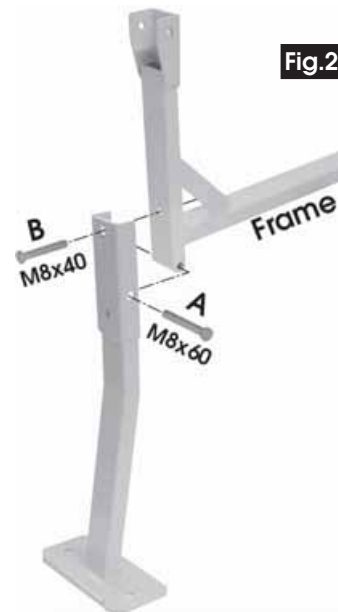

Fig.2

2. The Bottom Drum

- 2.1 Carefully lower the bottom drum assembly on to the stand as shown in Fig.. 3, so that the bearing blocks slot into the channels provided by the side supports.

The drive shaft end, i.e. that end where the pinion drives the drum, should be at the AXLE end of the Frame.

- 2.2 Line up the holes in the side support with those in the bearing block and enter an M8x60 bolt with flat washer and secure using a nut and spring washer.



Fig.3

3. The Upper Drum

Note:

Before bolting down the upper drum section, it is necessary to perform a 'dry run' in order to determine the correct orientation, to ensure all components are correctly aligned.

- 3.1. Lower the upper drum section on to the lower drum.

Rotate it until the position is found where the mixing blade upper mounting hole lines up with the corresponding hole in the upper drum section, and the lower mounting hole becomes aligned with the hole in the base of the lower drum section.

Mark this position on the upper and lower rims with a pencil or chalk mark, then remove the upper drum section.

- 3.2. Apply a film of impact adhesive (not supplied) to the rim of the drum, according to the manufacturers instructions, and ensuring the rim is perfectly clean beforehand. Position the rubber seal on to the rim so that the holes in the seal and those in the rim of the drum are aligned.

- 3.3. With assistance, lower the Upper Drum section on to the Lower Drum, so that the two marks, previously made, are aligned.

Insert M6 x 18 bolts into each of the holes in the rim together with a flat washer, and secure from below with a spring washer and nut, ensuring the tightening process is carried out progressively.

- 3.4. Secure the Mixing Blades to the Upper Drum by inserting an M6x20mm screw with a flat and leather washer, through the hole in the drum and through the upper mounting hole in the mixing blade.

Secure on the inside using a flat washer, spring washer and nut. Do not tighten at this stage.

- 3.5. Secure the Mixing Blades to the lower drum in a similar manner, ensuring the leather washers are in place.

- 3.6. Finally, tighten both top and bottom Mixing Blade mountings.

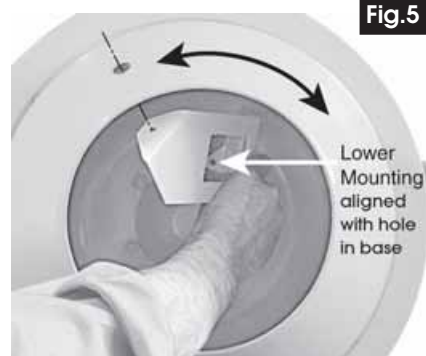
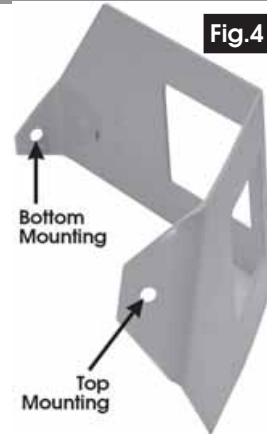

4. The Collar

- 4.1. Liberally grease the underside of the rim of the drum.

- 4.2. Wrap the collar around the rim of the drum and secure using the M6 bolts with flat and spring washers provided. Ensure flat washers are used at the bolthead and at the nut.

Tighten the clamping nuts - A before tightening the locating bolts -B

IMPORTANT:
The Drum Collar is a Safety Feature, and must ALWAYS be in place. NEVER operate the machine with the collar removed.

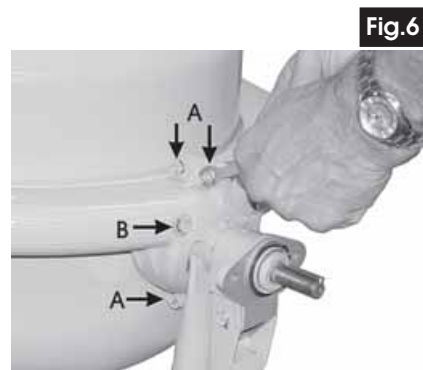

5. The Hand Wheel & Fittings

- 5.1 Slide the Locking Plate over the large diameter shaft, at the leg end of the frame, with the rim facing inwards, as shown in Fig.6.

Secure with two M8x25 bolts with nut, spring and flat washers

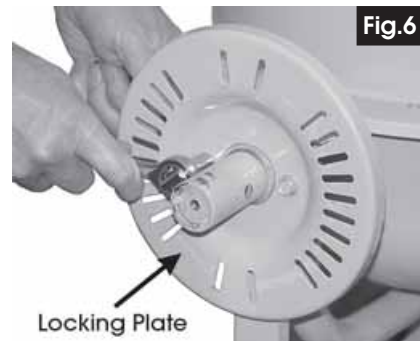

- 5.2 Insert the spring, into its holder in the Handwheel, and holding it in place as shown in Fig.7, slide the wheel over the large diameter shaft so that the shaft retains the spring.

NOTE:

This operation may need a little exertion in order to compress the spring sufficient to be able to slip the handwheel on to the shaft.

- 5.3 Line up the holes in the bracket on the handwheel with the hole drilled in the shaft, then insert the M10 x 65mm bolt with flat washer at the bolt head.

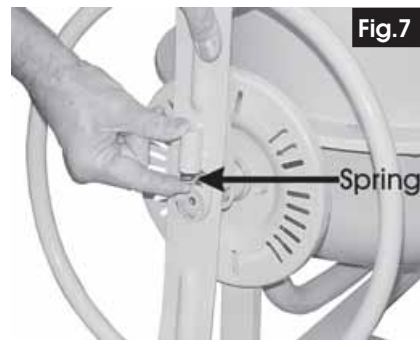

NOTE:

You will find it an easier task to line up the holes on one side of bracket only, to begin with. Enter the bolt, then use that as a pivot, by pushing the handwheel IN to square it up, in order to line up the holes on the other side. When the holes at the opposite side are aligned, tap the bolt through GENTLY to avoid damaging the threads.

- 5.4 Screw on two nuts. Screw the first nut up against the bracket, but not so tightly so as to prevent the handwheel from pivoting about the bolt. Lock the nut in this position by screwing up the second nut so that they are tight against each other.

NOTE:

The handwheel must be allowed to pivot about the bolt so that the lugs on the handwheel can be engaged or disengaged from the slots in the Locking Plate.



- 5.5 Finally, screw the handle into the handwheel hub, tightly

6. The Motor Covers and Fittings

- 6.1 Bolt the Inner Cover to the Bearing Block. Use two M8 x 25mm bolts, with flat washers at the bolt heads, (within the Inner Cover), and spring washers with nuts to the rear of the Bearing Block. Tighten the nuts.
- 6.2 Bolt on the Motor Support Plate as shown in Figs. 9 and 10, by inserting two M6 x 50mm bolts, with flat washers, through the holes in:
 - a. the Support Plate
 - b. the slotted holes in the Inner Cover
 - c. the spacer, (which is inserted between the Inner Cover, and the Frame)
 - d. the Clamping plate.



NOTE:

The securing plate is steel, whereas the spacer is plastic and is the thicker of the two plates. Insert the first bolt and thread on the nut by one turn only, before inserting the 2nd bolt.

- 6.3 Thread on a spring washer and nut, but DO NOT tighten the nut at this stage
- 6.4 Slide the Pulley on to the shaft, having lined up the key and keyway. Ensure the grub screw in the hub of the pulley faces outwards. Push the pulley on to the shaft until the end of the shaft is slightly proud of the central boss. This is not a critical measurement. Lock the pulley in this position by tightening the grub screw.
- 6.5 Slip the drive belt over the pulley
- 6.6 If the Motor pulley is not fitted, slide it on to the shaft fully and tighten the grub screw using a hex. wrench.
- 6.7 Place the motor, (which has the Outer Cover attached via the power cable), on the motor support plate, and slip the drive belt over the pulley. It may be necessary to manoeuvre the Motor support upwards to achieve this.

Fig.10

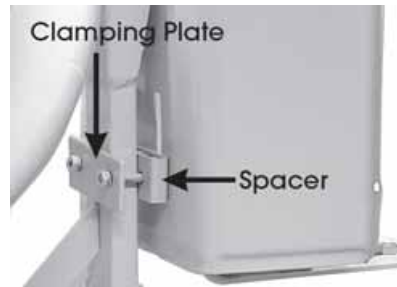

NOTE: It is now most important that the motor pulley be aligned so that it is directly in line with the driven pulley. This is achieved as follows:

- 6.8 Bolt the Motor, square on the Support so that the back edge of the motor mounts are 25mm from the edge of the support (see Fig. 11).
- 6.9 Allow the motor and Support to drop as far as possible under its own weight in order to tension the drive belt. Tension is correct when there is approximately 1/4" total deflection at the centre of the belt run when using moderate thumb pressure. Tighten the mounting bolts progressively ensuring the support plate is parallel to the ground.
- 6.10 Finally, attach the outer cover using the three screws provided.



OPERATION

The Drum will turn immediately the machine is switched ON. Ensure therefore that nothing can impede the drum before plugging into a 230 volt supply, and pressing the green ON button.

CAUTION: NEVER load the drum whilst it is stationary.

In order to rotate the drum, when stationary, pull the Hand Wheel outwards at the rim to disengage the wheel from the Locking Plate (Fig.13). Turn the drum to the required position then release the handwheel to lock it in that position.



Fig.12

Fig.13



Note that the ON/OFF switch is a No Volt Release Type. Therefore, should power be lost, the machine will switch OFF automatically, and will not restart once power is restored.

MAINTENANCE - General

Before each use

Inspect the machine to ensure it is not damaged and will perform its normal functions correctly. If any damage is apparent, have it fixed before putting into service.

Periodically

Inject a few drops of light oil into the oil points, located on top of the Bearing Blocks and rotate the drum to ensure distribution of oil within the bearing surface.

Inspect the paintwork and remove any rust that may be apparent before touching up where necessary, with a rust resistant paint.

It is recommended that the Collar be removed, at least annually, and grease smeared on the serrated underside of the lower rim. Ensure the collar is replaced correctly.

After each use.

It is strongly recommended that the machine is hosed down thoroughly with clean water, taking care to prevent water from entering the electrical components during the cleaning process. Turn the drum so that it is face down to allow all water to drain off. Protect it from the elements by covering with a tarpaulin. This is particularly important if the machine is to be stored for a period of time.

Storage

It is possible to fold the leg and axle assembly beneath the frame by removing their upper mounting bolts, and slackening off the lower mounting bolts so that the leg, or axle assembly, pivots beneath the frame, as illustrated.



SPARE PARTS LIST

No.	Description	Qty	Part No.	No.	Description	Qty	Part No.
1	Frame	1	SDCCM5001	34	Spring	1	SDCCM5034
2	Axle Bracket	1	SDCCM5002	35	Lower drum	1	SDCCM5035
3	Support Bracket	1	SDCCM5003	36	Rubber Seal	1	SDCCM5036
4	Wheel	2	SDCCM5004	37	Upper Drum	1	SDCCM5037
5	Cup Washer	4	SDCCM5005	38	Mixer Blade	2	SDCCM5038
6	Split Pin 3x30	2	SDCCM5006	39	Hex Bolt M10 x65	1	SDCCM5039
7	Lock Nut M16x1.5	2	SDCCM5007	40	Hex Bolt M8x60	2	SDCCM5040
8	Motor Mount Plate	1	SDCCM5008	41	Hex Nut M10	1	SDCCM5041
9	Spacer	1	SDCCM5009	42	Spring Washer	1	SDCCM5042
10	Motor Pulley	1	SDCCM5010	43	Hex Nut M8	14	SDCCM5043
12	Motor	1	SDCCM5012	44	Spring Washer	14	SDCCM5044
13	Lock Screw M8x8	2	SDCCM5013	45	Flat Washer 8	14	SDCCM5045
14	Switch Assembly	1	SDCCM5014	46	Flat Washer 6	16	SDCCM5046
15	Outer Motor Cover	1	SDCCM5015	47	Spring Washer 6	12	SDCCM5047
16	Pulley	1	SDCCM5016	48	Hex Nut M6	12	SDCCM5048
17	Inner Motor Cover	1	SDCCM5017	49	Hex. Hd Scr M5x10	3	SDCCM5049
18	Pulley Belt A560mm	1	SDCCM5018	50	Flat Washer M5	3	SDCCM5050
19	Shaft Pin 38	4	SDCCM5019	51	Spring Washer M5	3	SDCCM5051
20	Washer	4	SDCCM5020	52	Hex Nut M5	3	SDCCM5052
21	Bearing Bracket	2	SDCCM5021	53	Hex Screw M6 x 20	6	SDCCM5053
22	Flat Key 5x35	1	SDCCM5022	54	Leather Washer	4	SDCCM5054
23	Dust Cover	1	SDCCM5023	55	Flat Washer 10	1	SDCCM5055
24	Shaft	1	SDCCM5024	56	Hex. Hd Bolt M6x18	6	SDCCM5056
25	Bearing 6002-2RS	2	SDCCM5025	57	Hex Bolt M6 x 60	2	SDCCM5057
26	Pinion	1	SDCCM5026	58	Hex Bolt M8 x 25	4	SDCCM5058
27	Support Arm Assy	1	SDCCM5027	59	Hex Bolt M8 x 20	4	SDCCM5059
28	Brg Cover, Upper	1	SDCCM5028	60	Hex Bolt M8 x 40	2	SDCCM5060
29	Brg Cover, Lower	1	SDCCM5029	61	Hex Bolt M8 x 60	2	SDCCM5061
30	Shaft Pin 020	2	SDCCM5030	62	Handle Assembly	1	SDCCM5062
31	Bearing 6204-2RS	2	SDCCM5032	63	Clamping Plate	1	SDCCM5063
32	Locking Plate	1	SDCCM5032	64	Drum Collar 2-piece	1	SDCCM5064
33	Wheel Assembly	1	SDCCM5033				

PARTS DIAGRAM

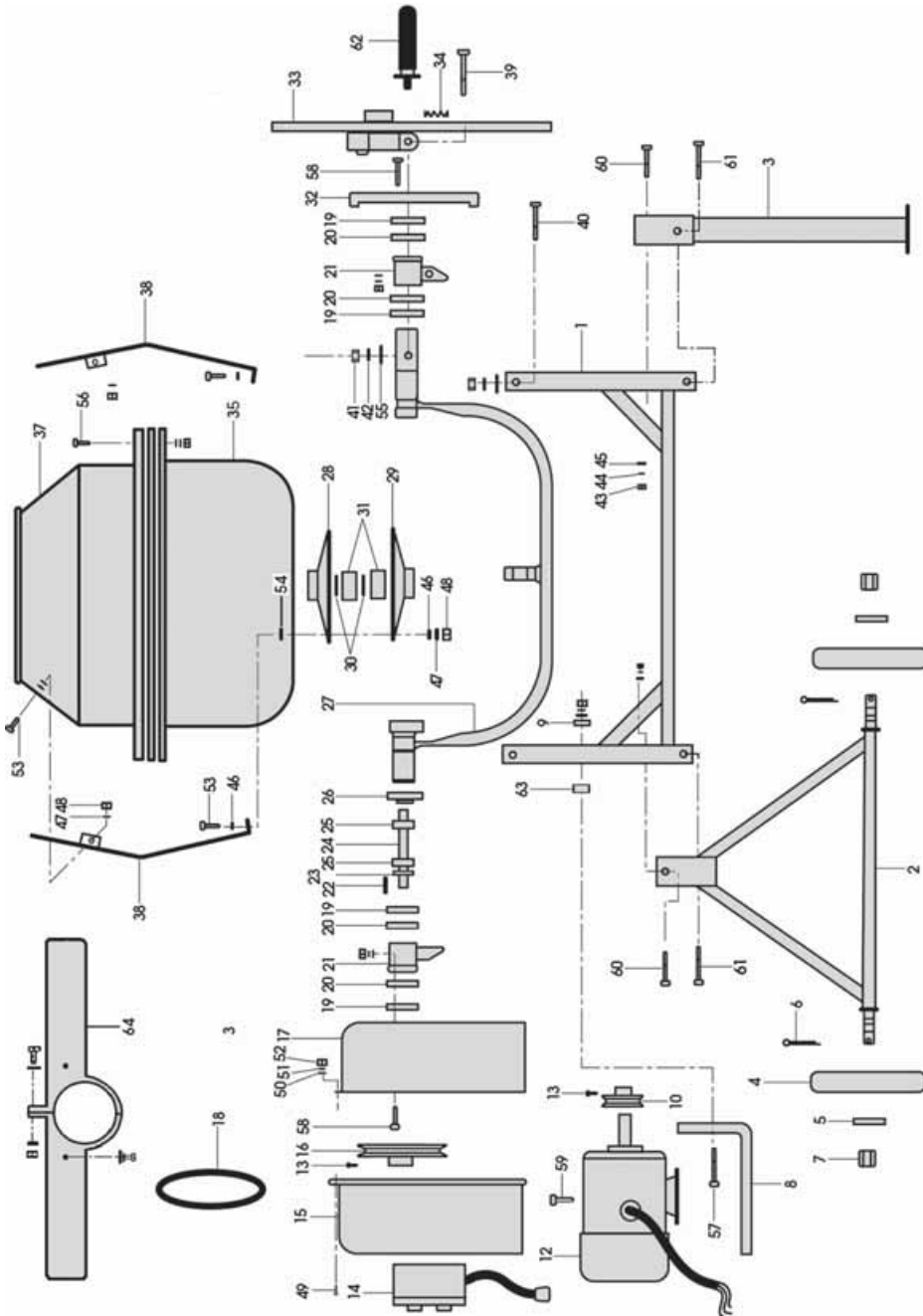

This is an important document, and should be retained.

DECLARATION OF CONFORMITY

We declare that this product complies to the following standards/directives:

- **98/37/EC**
- **2000/14/EC**

Guaranteed Sound
Power Level: **92 dBL_{WA}**

Product Description: **CEMENT MIXER**
Model Number: **CCM50**
Serial (Batch) No: **See product Data Plate**

Signed 
Service Manager

Clarke INTERNATIONAL
Hemnal Street, Eddina, Essex CM16 4LG

Clarke International is a trading style of Clarke International Limited

SPARE PARTS & SERVICE CONTACTS

**Please contact your nearest dealer, or
CLARKE International, on one of the following numbers.**

PARTS & SERVICE TEL: 020 8988 7400

PARTS & SERVICE FAX: 020 8558 3622

or e-mail as follows:

PARTS: Parts@clarkeinternational.com

SERVICE: Service@clarkeinternational.com