

# Model No. VC3012M VACUUM CLEANER

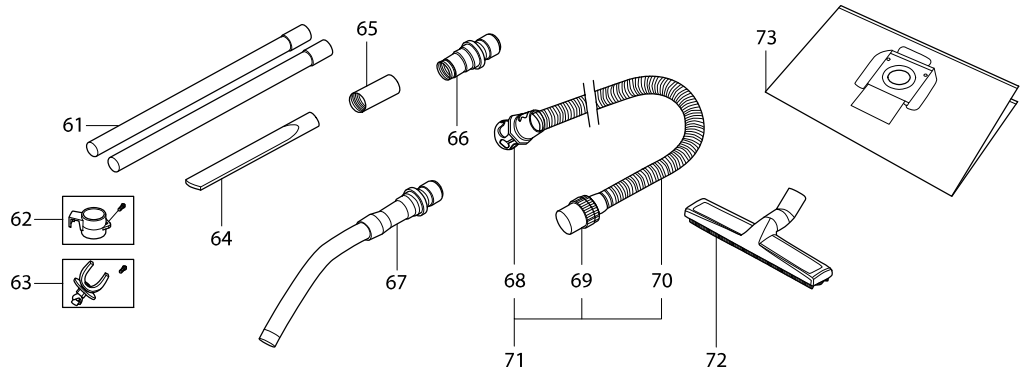

# Model No. VC3012M VACUUM CLEANER

Item	Parts No.	Description	I/C	QTY	N/O	Opt. 1	Opt. 2	NOTE
001	W107417282	DEDUSTING KNOB (BLUE) WITH ROD		1				
002	W302004029	SCREW 5X18 TX20		3				
003	W302004032	SCREW 3,5X18 TX10		2				
004	W302004019	HANDLE (KIT)		1				
005	W302004026	TOOLBOX		1				
006	W107404542	CAPACITOR 0,1		1				
007A	W107400494	ELECTRONICS 2M PC 100-120V		1				
007B	W107400491	ELECTRONICS 2M PC 230V SET-1		1				
008	W107413449	SWITCH KIT WITH POTENTIOMETER		1				
009	W302000429	ELECTRONIC POTENTIOMETER		1				
010	W107418011	SWITCHCASE VC3012M		1				
011	W107400575	TURNING KNOB FOR POTI		1				
012	W107400576	O-RING 21X1.5		1				
013	W107400264	WIRE 1SQX150 GR/YE		1				
014	W107417284	COVER MAKITA VC3012L/M (KIT)		1				
D10		INC. 16						
015A	W107400057	SOCKET *GB* - CEE 3 POL-110V		1				
015B	W302004336	SOCKET *GB* - BS-1363		1				
016	W302004032	SCREW 3,5X18 TX10		2				
017	W909100222	SWITCH KNOB MAKITA BLUE		1				
D10		INC. 18						
018	W9868	O-RING 10x2.5 NBR70		1				
019	W107416958	BUZZER KIT VC4210M		1				
020	W302004015	AIRFLOW CHANNEL		1				
021	W302004032	SCREW 3,5X18 TX10		2				
022	W302004030	STRAP FOR CORD		1				
023	W302004061	O-RING 25X2 NBR70		1				
024	W107416952	FLOW SENSOR		1				
025	W55416	O-RING 4.0X1.5 NBR70		1				
026	W107400578	HOSE CLAMP D10		1				
027	W302004031	TERMINAL STRIP 6-POL 16A		1				
028	W302004009	CLAMPING PLATE MAKITA VC3012		1				
029	W302004023	CONTACT SPRING WITH WIRE		1				
031B	W302001416	POWER CORD GB		1				
034A	W302000692	POWER CORD *GB*-CEE3POL-110V		1				
036	W302004029	SCREW 5X18 TX20		7				
037	W302004045	SOUND ABSORBER FOR AIR OUTLET		1				
038	W302003385	ELASTIC SUSPENSION (KIT)		1				
039A	W107417417	TURBINE 1200W 110-120V (KIT)		1				
039B	W302003384	TURBINE 1200W 220-240V (KIT)		1				
040	W302004010	SOUND ABSORBER FOR BASE PLATE		1				
041	W909100083	TORSION SPRING		1				
042	W302000344	FLAP FOR FILTER CLEANING		1				
043	W107401937	PLUG FOR BASE PLATE		1				
044	W302004007	BASE PLATE VC3012		1				
D10		INC. 43						
045	W107400301	CONTAINER CLAMP (KIT-2X)		1				
046	W107400056	GASKET FOR CONTAINER		1				

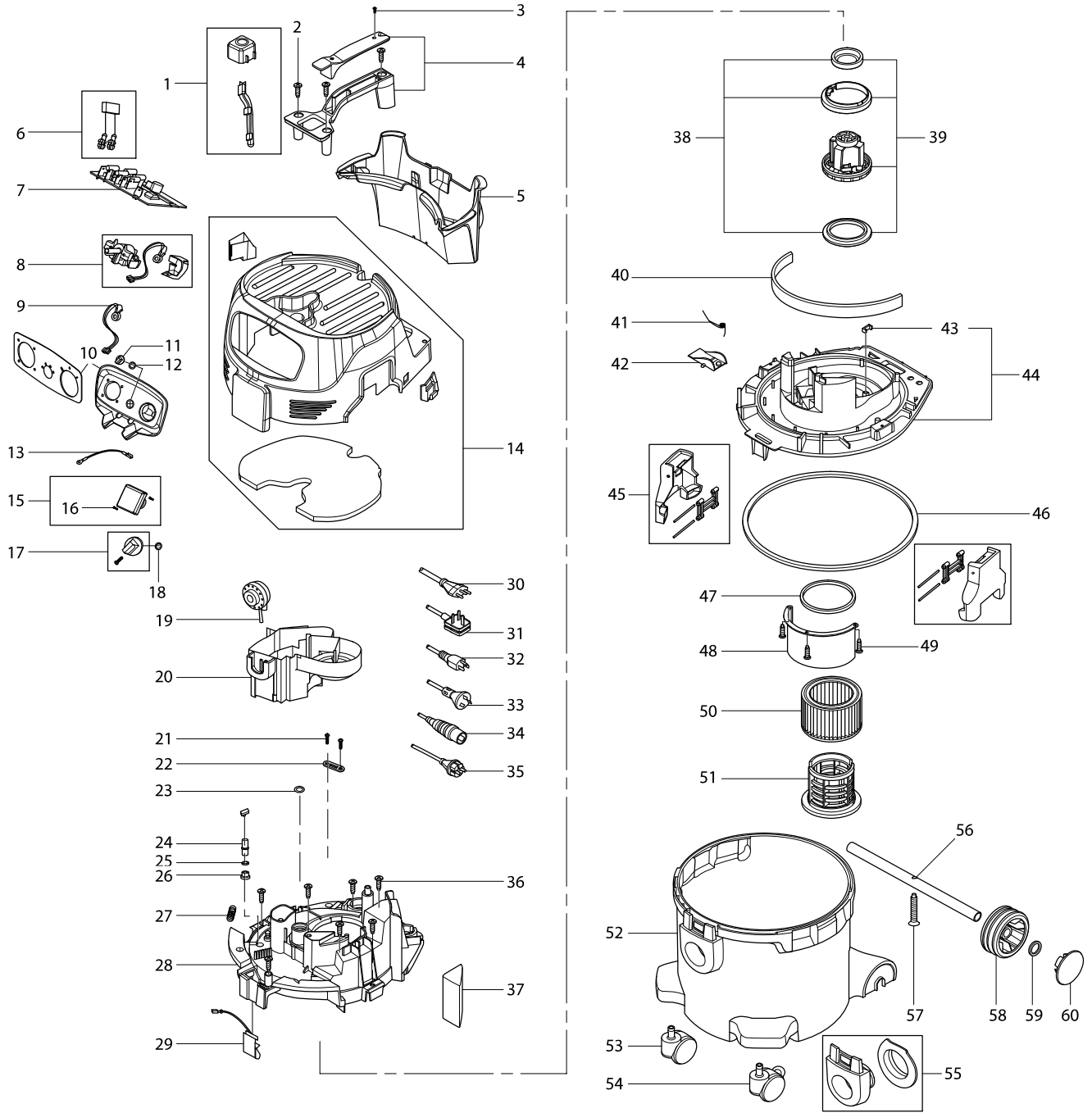