



INSTRUCTIONS FOR

WORKSTATION WITH 2 DRAWERS & 2 CUPBOARDS

MODEL NO: **AP1372A**

Thank you for purchasing a Sealey product. Manufactured to a high standard, this product will, if used according to these instructions, and properly maintained, give you years of trouble free performance.

IMPORTANT: PLEASE READ THESE INSTRUCTIONS CAREFULLY. NOTE THE SAFE OPERATIONAL REQUIREMENTS, WARNINGS & CAUTIONS. USE THE PRODUCT CORRECTLY AND WITH CARE FOR THE PURPOSE FOR WHICH IT IS INTENDED. FAILURE TO DO SO MAY CAUSE DAMAGE AND/OR PERSONAL INJURY AND WILL INVALIDATE THE WARRANTY. KEEP THESE INSTRUCTIONS SAFE FOR FUTURE USE.



Refer to Instructions

1. SAFETY

- WARNING!** Ensure Health & Safety, local authority, and general workshop practice regulations are adhered to when using this bench.
- ✓ Locate bench in a suitable working area.
- ✓ Keep the work area clean, uncluttered and ensure there is adequate lighting.
- WARNING!** Use bench on level and solid ground, preferably concrete. Avoid tarmac since the bench may sink into the surface.
- ✓ Keep the bench clean and tidy in accordance with good workshop practice.
- ✓ Keep children and unauthorised persons away from the working area.
- * **DO NOT** use the bench for any purpose other than that for which it is designed.
- * **DO NOT** exceed maximum capacity of workbench.
- * **DO NOT** undertake work on the bench without the work piece being adequately secured. Use clamps or a vice (not included) to secure the work piece. Available from your Sealey dealer.
- * **DO NOT** use the bench out of doors.
- * **DO NOT** get the bench wet or use in damp or wet locations or areas where there is condensation.
- * **DO NOT** clean the bench with any solvents which may damage the paint surface or the protective coating on the wooden top.

2. INTRODUCTION

Heavy duty powder coated metal frame with a 40mm MDF work surface. Two configurations available with a combination of lockable drawers and cupboards. Features adjustable feet to help stability when placing on an uneven surface. Supplied flat packed with two keys.

3. SPECIFICATION

Model no: AP1372A
 Size (W x D x H):..... 1200 x 600 x 865mm
 Drawer (x2): 415 x 160 x 415mm
 Capacity: 300kg

4. CONTENTS

4.1. Panels etc.

Part	Description	Quantity
A	Top	1
B1	Left side	1
B2	Right side	1
C	Bottom	1
D	Support	1
E	Drawer	2
F1	Left door	1
F2	Right door	1
G	Shelf	2
H	Back	2
I	Leg leveller assy.	4
J1	Left slide	2
J2	Right slide	2
K	Rail	2

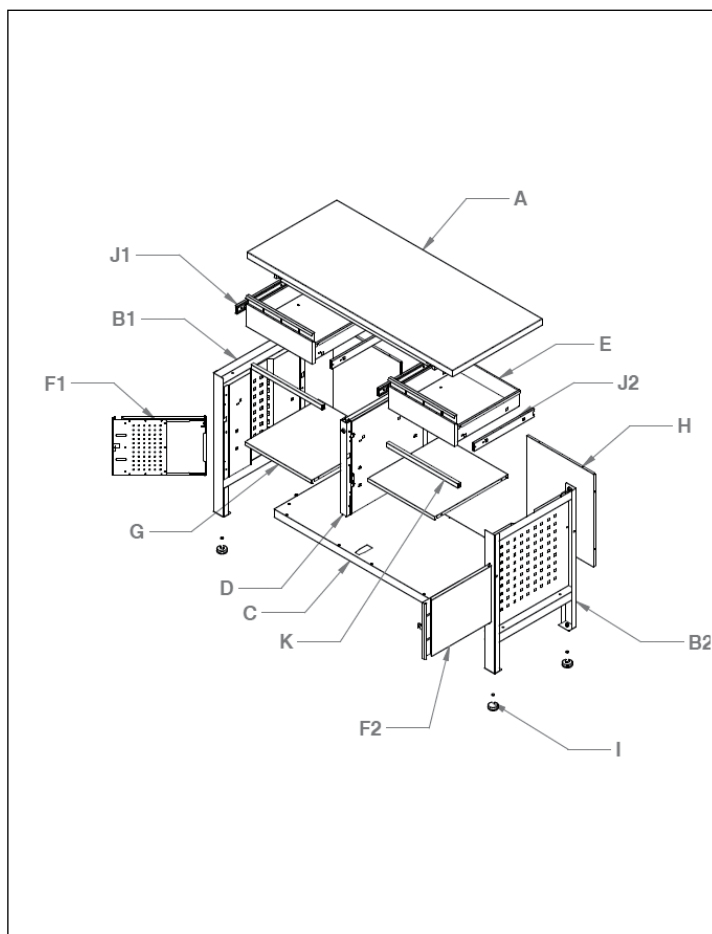

4.2. Hardware contents



Part	Description	Quantity
a	Bolts ST4. 8x10mm	12+2
b	Plastic rivet	16+4
c	Plastic pin	8

4.3. Before assembly check contents against the contents lists.

5. ASSEMBLY

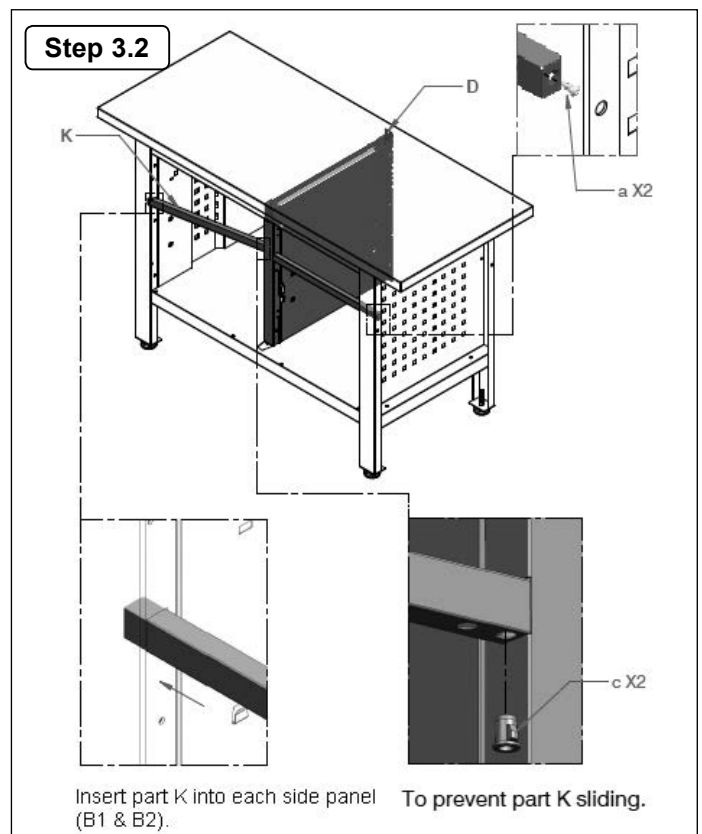
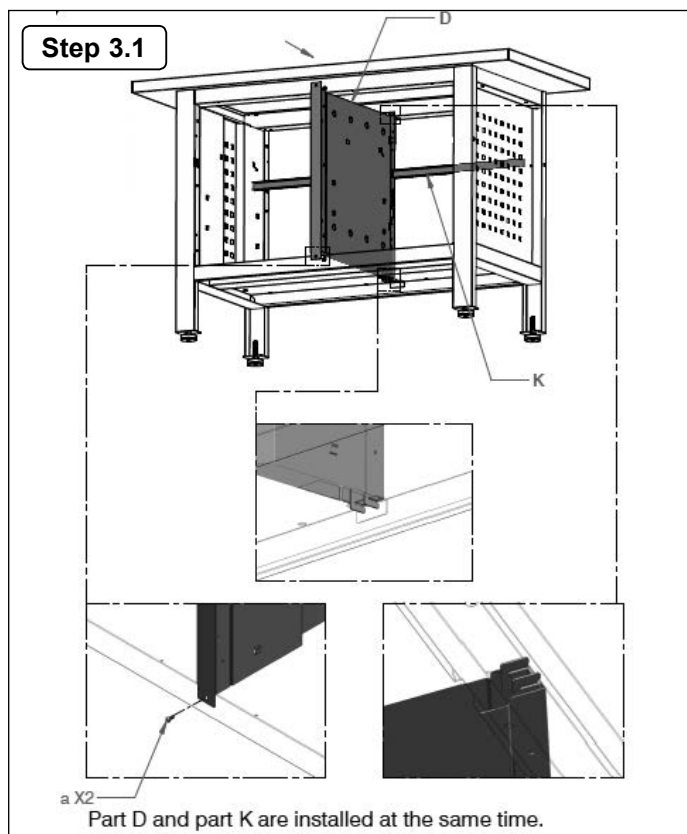
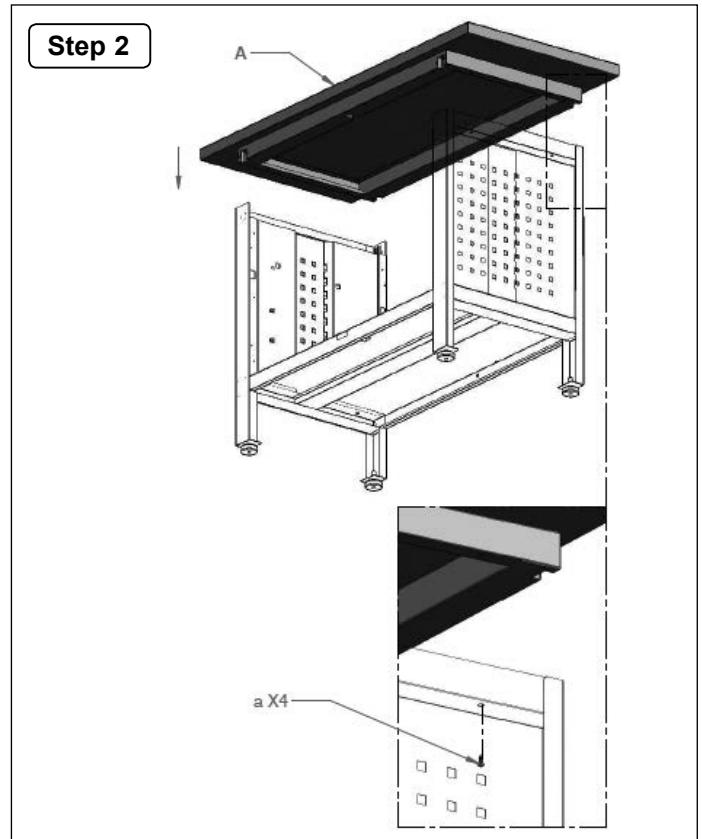
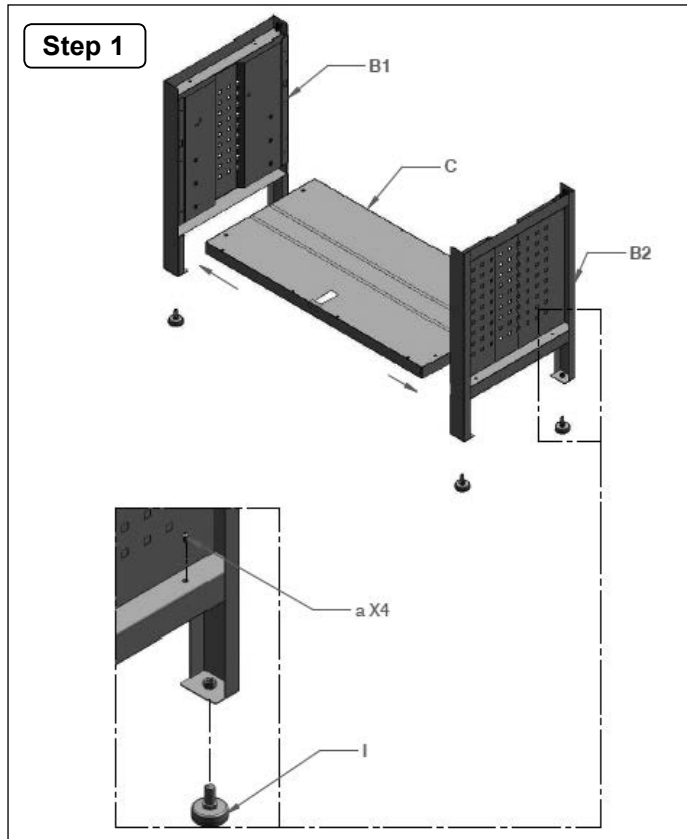

Step 4

Flick the plastic clips on the inside slide to detach the inside slide from the outside slide.

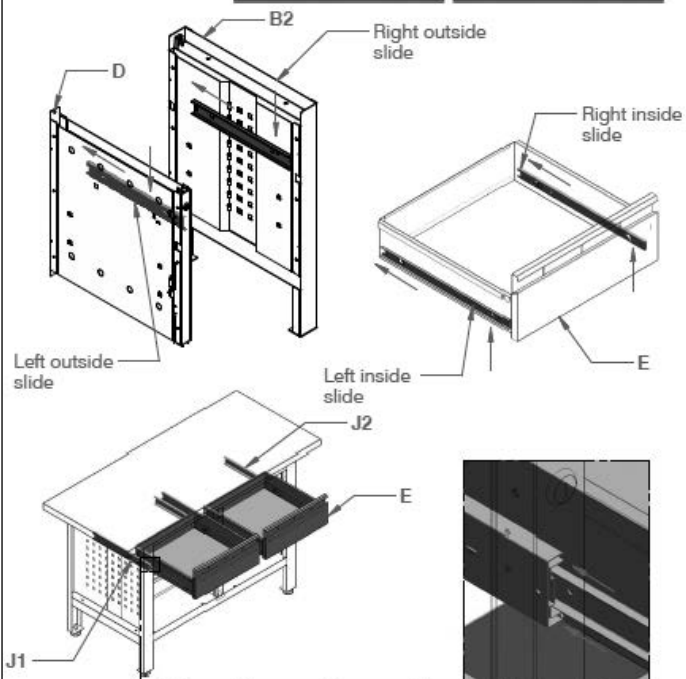
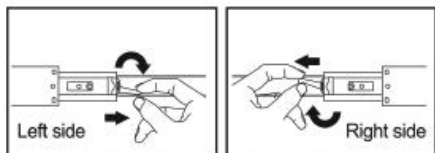

Step 5

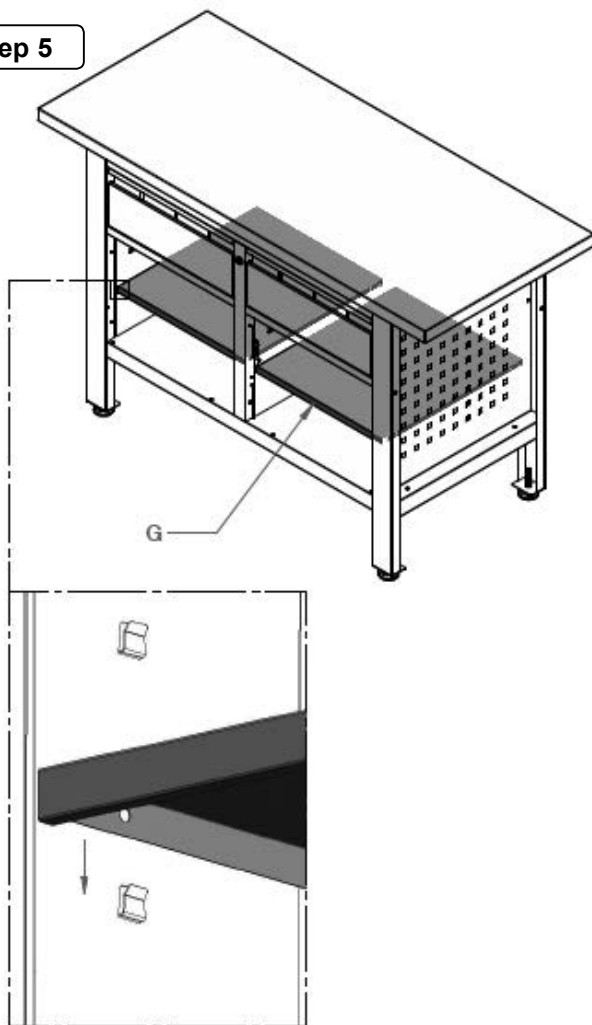

Step 6

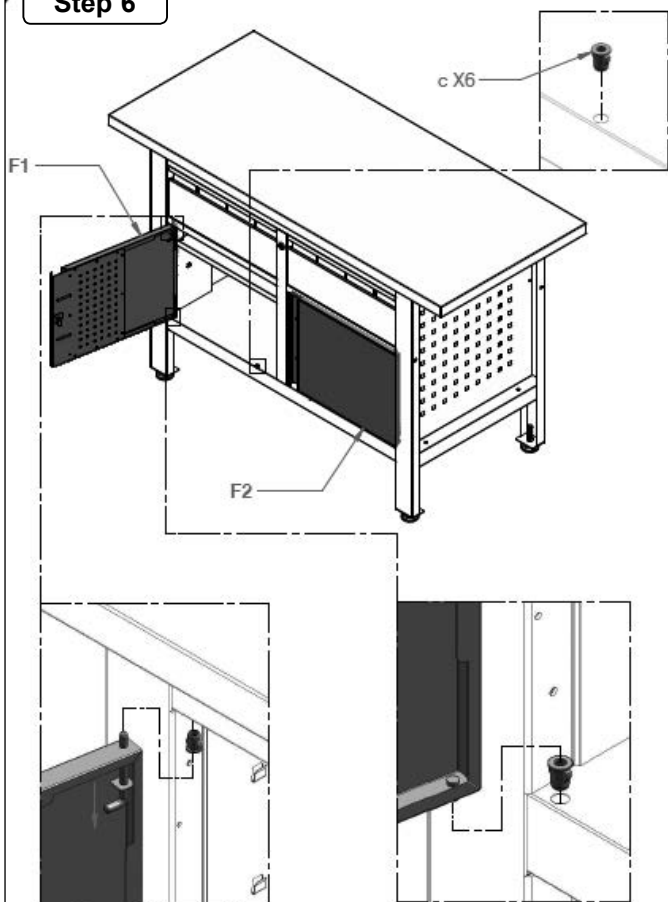

Step 7

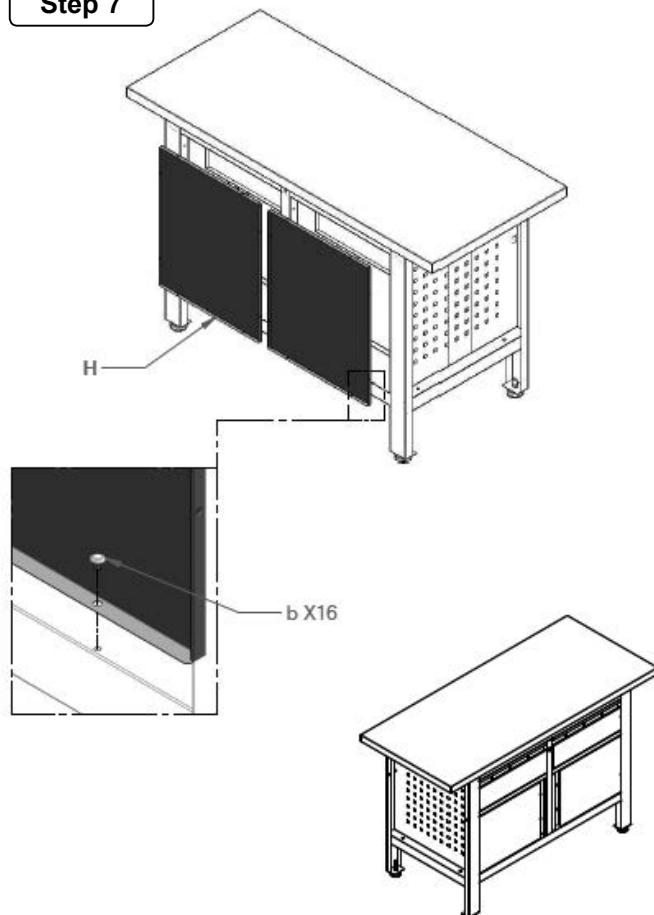



Environmental Protection

Recycle unwanted materials instead of disposing of them as waste. All tools, accessories and packaging should be sorted, taken to a recycling centre and disposed of in a manner which is compatible with the environment. When the product becomes completely unserviceable and requires disposal, drain off any fluids (if applicable) into approved containers and dispose of the product and the fluids according to local regulations.

NOTE: It is our policy to continually improve products and as such we reserve the right to alter data, specifications and component parts without prior notice.

IMPORTANT: No liability is accepted for incorrect use of this product.

WARRANTY: Guarantee is 12 months from purchase date, proof of which will be required for any claim.



Sole UK Distributor, Sealey Group.
Kempson Way, Suffolk Business Park,
Bury St. Edmunds, Suffolk.
IP32 7AR



01284 757500



01284 703534



www.sealey.co.uk



sales@sealey.co.uk