



INSTRUCTIONS FOR

MOTORCYCLE & QUAD SCISSOR LIFT 500KG CAPACITY HYDRAULIC

MODEL NO: **MC4500**

Thank you for purchasing a Sealey product. Manufactured to a high standard, this product will, if used according to these instructions, and properly maintained, give you years of trouble free performance.

IMPORTANT: PLEASE READ THESE INSTRUCTIONS CAREFULLY. NOTE THE SAFE OPERATIONAL REQUIREMENTS, WARNINGS & CAUTIONS. USE THE PRODUCT CORRECTLY AND WITH CARE FOR THE PURPOSE FOR WHICH IT IS INTENDED. FAILURE TO DO SO MAY CAUSE DAMAGE AND/OR PERSONAL INJURY AND WILL INVALIDATE THE WARRANTY. KEEP THESE INSTRUCTIONS SAFE FOR FUTURE USE.



Refer to
Instructions



Wear Safety
Footwear



Wear Protective
Clothing



Warning Crush-
ing of hands

1. SAFETY

- WARNING!** Ensure that the motorcycle is adequately secured to the lifting platform with appropriate straps before raising the load.
- WARNING!** Keep fingers away from scissor action of lift.
- ✓ Maintain the lift in good condition (use an authorised service agent).
- ✓ Replace or repair damaged parts. Use genuine parts only. Unauthorised parts may be dangerous and will invalidate the warranty.
- ✓ Use a qualified person to lubricate and maintain the lift. **DO NOT** use brake fluid to top up hydraulic unit.
- ✓ Locate the lift in a suitable work area, keep area clean and tidy and free from unrelated materials, and ensure that there is adequate lighting. Also ensure that the floor is level and strong enough (preferably concrete) to take the weight of the lift and the bike.
- * **DO NOT** operate the lift on tarmac, as the surface may be unstable.
- ✓ Keep the lift clean for best and safest performance.
- ✓ The maximum motorcycle weight is 500kg. **DO NOT** exceed this rated capacity.
- ✓ Remove ill fitting clothing. Remove ties, watches, rings and other loose jewellery, and contain long hair.
- ✓ Maintain correct balance and footing, do not over reach. Ensure the floor is not slippery and wear non-slip shoes.
- ✓ Before lifting check that there are no overhead obstructions.
- ✓ When platform has been raised to the working height ensure the safety locks are engaged to prevent accidental lowering.
- ✓ Keep children and unauthorised persons away from the work area.
- ✓ The lowering speed will vary according to the weight of the load and the operation of the release valve.
- * **DO NOT** use the lift for a task it is not designed to perform.
- * **DO NOT** operate the lift if damaged.
- * **DO NOT** exceed the rated capacity of the lift.
- * **DO NOT** operate the lift when you are tired or under the influence of alcohol, drugs or intoxicating medication.
- * **DO NOT** allow untrained persons to operate the lift.
- * **DO NOT** make any modifications to the lift.
- * **DO NOT** sit or stand on the lift or hold onto it when it is being raised or lowered.
- * **DO NOT** allow anyone to stand near the lift whilst raising or lowering.
- * **DO NOT** use the ram alone to maintain a raised motorcycle. **ALWAYS** use the two mechanical safety locks.
- ✓ Before lowering the lift ensure that there are no obstructions underneath and that all persons are standing clear.
- ✓ Before storing in safe area, ensure all parts are clean and free of grease and oil. Store lift in the lowest position.
- WARNING!** The warnings, cautions and instructions referred to in this manual cannot cover all possible conditions and situations that may occur. It must be understood that common sense and caution are factors which cannot be built into this product, but must be applied by the operator.

2. INTRODUCTION

Heavy steel construction with bottle jack style hydraulic unit. Lifting arms suitable for lifting bikes with a suitable structure, quads, all terrain vehicles, trikes and transmissions. Features 2 mechanical safety locks lockable in 4 positions for supporting the motorcycle for extended periods on the lift. Mounted on two fixed wheels and 2 double castors for manoeuvrability. The lift can be used with or without the supplied frame supports. Space saving design maximises garage working area. With a low minimum height of 110mm (200mm with frame supports), it will lift and support the bike through a full lift up to a maximum height of 400mm (508mm with frame supports). Unlike most other motorcycle lifts, it is possible to remove both wheels, front forks, steering assembly, rear swing arm and suspension units as well as the engine. Can be used anywhere on a hard level floor thus making this suitable for mobile motorcycle mechanics. Ideal for use with the Sealey range of wheel chocks to assist supporting the motorcycle whilst adjusting the frame supports and securing to the lift

3. SPECIFICATION

Model No:.....MC4500
Capacity:..... 500kg
Min./Max Lift height (without frame supports)..... 110x400mm
Min./Max Lift height (with frame supports).....200x508mm
Maximum Frame dimensions (WxD)680x360mm

4. OPERATION

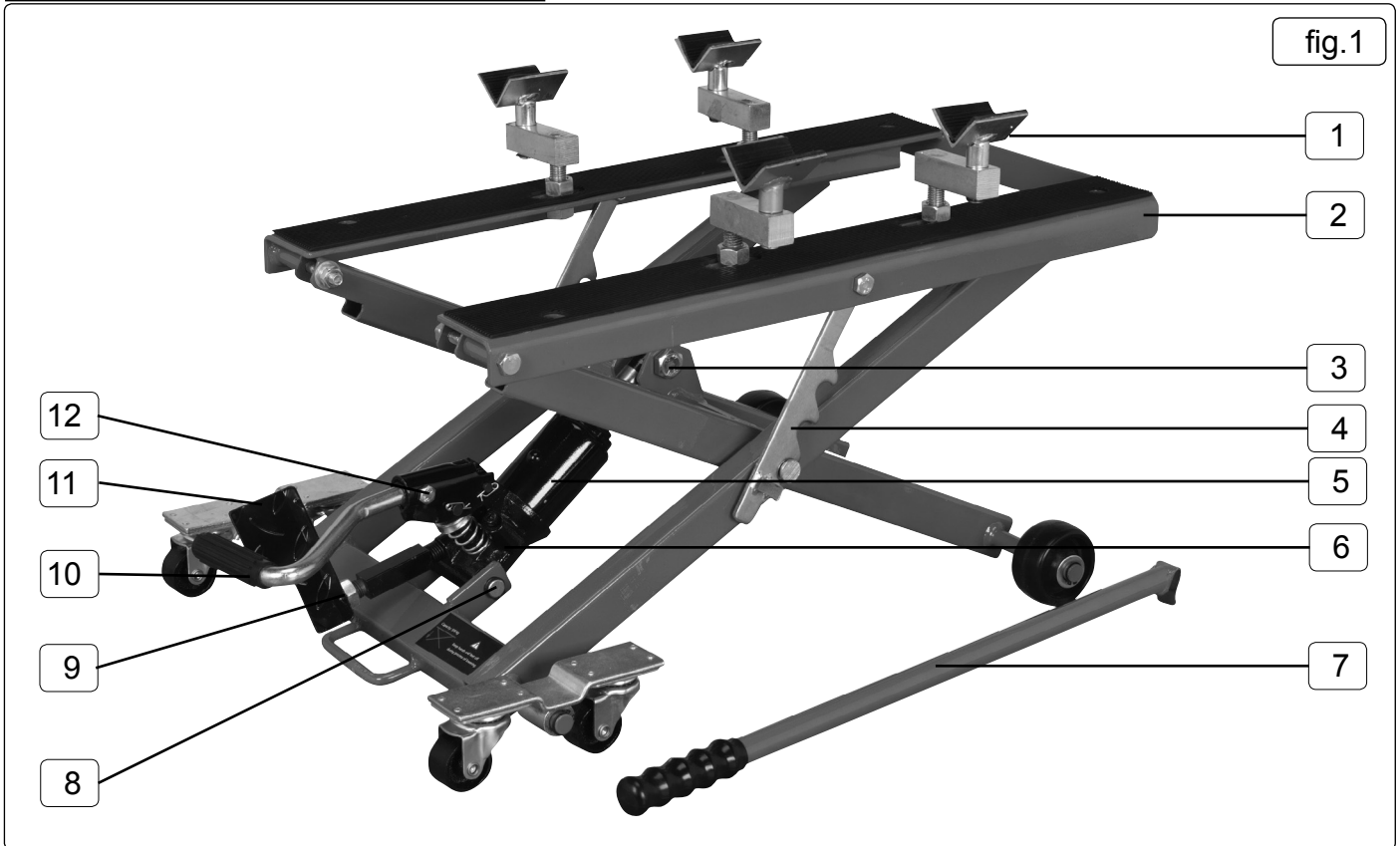

- 1.....Frame Supports
- 2.....Platform
- 3.....Set Screw M14x100 & Nut M14
- 4.....Safety Locks
- 5.....Hydraulic Pump
- 6.....Vent / Oil filling screw
- 7.....Pulling Handle
- 8.....Spindle & Circlips
- 9.....Locking nut
- 10.....Lift Foot Pedal
- 11.....Release Foot Pedal
- 12.....Set Screw M8x80

Fig.1 Shows fully assembled Lift

- 4.1. Prior to use vent the lifting cylinder, to do this have the lift in the lowered position, open the vent / oil filling screw (6) until a small amount of oil seeps out. Close the vent screw.
- 4.2. To top up oil remove screw (6) fill with good quality jack oil, replace screw.
- 4.3. Position the lift in a suitable area, checking that the surface on which the lift will stand is solid and flat (preferably concrete).
- 4.4. Use the Pulling handle to position the lift centrally under the motorcycle, remove the pulling handle.
- 4.5. The lift may be used either with or without the frame supports (1) in place. To use frame supports put a nut on stud and position the stud through the slot in the platform and secure the supports in the correct position with second nut.
- 4.6. Adjust the position of the frame supports beneath the frame, taking care not to damage any exhaust components, pipes or cables.
- 4.7. **TO LIFT:** Close the release foot pedal (11) valve fully (clockwise) and use the Lift foot pedal to raise the cradle into light contact with the motorcycle frame. Tighten the nuts on the frame supports to lock in position.
- 4.8. Secure the load with ratchet straps.
- 4.9. * **DO NOT** attempt to lift a motorcycle without securing to the cradle with suitable ratchet straps.
Pump up to a convenient height.
* **DO NOT** leave the load supported by the hydraulic unit alone, use safety locks (4) release from platform by pushing down, then operating the release foot pedal slightly to engage the safety locks. (as in fig.1)
- 4.10. **TO LOWER:** Before lowering ensure that the area below the cradle is clear and that everyone stands well clear of the Lift. Close the release foot pedal (clockwise) and pump the lift foot pedal slightly to release the safety locks and clip them on to edge of platform.
- 4.11. Use the release foot pedal gradually to allow the lift to descend gently. When the motorcycle is bearing its own weight, close the release foot pedal (clockwise) and remove the strapping; when removed, open the release foot pedal again to allow the lift to settle at its minimum height.
- 4.12. Withdraw the lift from beneath the motorcycle, using the pulling handle.
- 4.13. Store in a safe, dry, child proof location when not in use.

5. MAINTENANCE

- 5.1. When the lift is not in use, it must be returned to its lowest position to minimise ram and piston corrosion.
- 5.2. Keep the lift clean and wipe off any oil or grease. Lubricate all moving parts..
- 5.3. Before each use check all parts. If any part of the lift is damaged or suspect, remove lift from service and take necessary action to repair.
 - * **DO NOT** use the lift if it is believed to have been subjected to abnormal load or shock. Inspect and take appropriate action.
- 5.4. Check the ram and piston periodically for signs of corrosion. Clean exposed areas with a clean oiled cloth.
- 5.5. Topping up the oil. Top up the oil as in section 4.2. Use only a good quality jack oil, such as Sealey Jack Oil.
 - * **DO NOT** use any other fluid such as: brake fluid, automatic transmission fluid or engine oil.

6. TROUBLESHOOTING

SYMPTOM	POSSIBLE COURSE	SOLUTION
Jack will not lift load	Release valve not tightly closed	Close foot release valve
	Overload condition	Remove / Release load
	Hydraulic unit malfunction	Service hydraulic unit
Jack will lift but not retain pressure	Foot release valve not tightly closed	Close foot release valve fully
	Overload condition	Remove / Reduce load
	Hydraulic unit malfunction	Service hydraulic unit
Jack will lift but not lower after unloading	Reservoir over filled	Drain fluid to correct level
	Linkage binding	Clean and lubricate moving parts
Poor lift performance	Fluid level low	Ensure proper fluid level
	Air trapped in system	Bleed System

IMPORTANT: NO RESPONSIBILITY IS ACCEPTED FOR INCORRECT USE OF THE LIFT.

Hydraulic products are repaired by local service agents only. We have service/repair agents in all parts of the UK.

DO NOT return the product to us. Please call us on 01284 757500 to obtain the address and telephone number of your local agent.

If the product is under guarantee please contact your dealer.

De-commissioning: Should the lift become completely unserviceable, draw off the oil into an approved container and dispose of the lift and the oil according to local regulations.

Parts support is available for this product. To obtain a parts listing and/or diagram, please log on to www.sealey.co.uk, email sales@sealey.co.uk or telephone 01284 757500.



Environmental Protection

Recycle unwanted materials instead of disposing of them as waste. All tools, accessories and packaging should be sorted, taken to a recycling centre and disposed of in a manner which is compatible with the environment.

When the product becomes completely unserviceable and requires disposal, drain off any fluids (if applicable) into approved containers and dispose of the product and the fluids according to local regulations.

NOTE: It is our policy to continually improve products and as such we reserve the right to alter data, specifications and component parts without prior notice.

IMPORTANT: No liability is accepted for incorrect use of this product.

WARRANTY: Guarantee is 12 months from purchase date, proof of which will be required for any claim.



Sole UK Distributor, Sealey Group.
Kempson Way, Suffolk Business Park,
Bury St. Edmunds, Suffolk.
IP32 7AR



01284 757500



01284 703534



www.sealey.co.uk



sales@sealey.co.uk