



INSTRUCTIONS FOR:
BOSCH / DELPHI
DIESEL INJECTOR PULLER
 MODEL NO: **VS2049**

Thank you for purchasing a Sealey product. Manufactured to a high standard, this product will, if used according to these instructions, and properly maintained, give you years of trouble free performance.

IMPORTANT: PLEASE READ THESE INSTRUCTIONS CAREFULLY. NOTE THE SAFE OPERATIONAL REQUIREMENTS, WARNINGS & CAUTIONS. USE THE PRODUCT CORRECTLY AND WITH CARE FOR THE PURPOSE FOR WHICH IT IS INTENDED. FAILURE TO DO SO MAY CAUSE DAMAGE AND/OR PERSONAL INJURY AND WILL INVALIDATE THE WARRANTY. KEEP THESE INSTRUCTIONS SAFE FOR FUTURE USE.

1. SAFETY

- ❑ **WARNING!** Ensure Health and Safety, local authority and general workshop practice regulations are adhered to when using tools.
 - X **DO NOT** use the kit if any parts are missing or damaged.
 - X **DO NOT** use this tool for any purpose other than that for which it is designed.
 - ✓ Switch off vehicle ignition and disconnect the battery before working under the bonnet.
 - ✓ When work on the vehicle is finished ensure that there are no tools left under the bonnet.
 - ✓ Maintain the tool components in good and clean condition for best and safest performance.
 - ✓ Wear approved eye protection. A full range of personal safety equipment is available from your Sealey dealer.
 - ✓ Wear suitable clothing to avoid snagging. Do not wear jewellery and tie back long hair.
 - ✓ Keep children and other unauthorised persons away from the working area.
 - ✓ Ensure there is adequate lighting prior to using this tool.
- IMPORTANT:** Always refer to the vehicle manufacturer's service instructions, or proprietary manual, to establish the current procedures and data.

2. INTRODUCTION

Suitable for the removal of stubborn Bosch/Delphi diesel injectors. Set includes two adaptors for different removal methods. The first screws onto the injector cap and the second locates internally inside the injector allowing for extra force to be used. Features a flexible joint allowing the slide hammer to be used in restricted areas. Supplied with instructions in carry-case.

3. SPECIFICATION

Contents: 1.8kg Slide Hammer, Flexible Joint, 2 x Adaptors, Security Hex Key 10mm, Injector Cap Socket.

Adaptor Thread Sizes:

Ø17mm Male x 1mm Pitch, Ø28mm Female x 1mm Pitch.

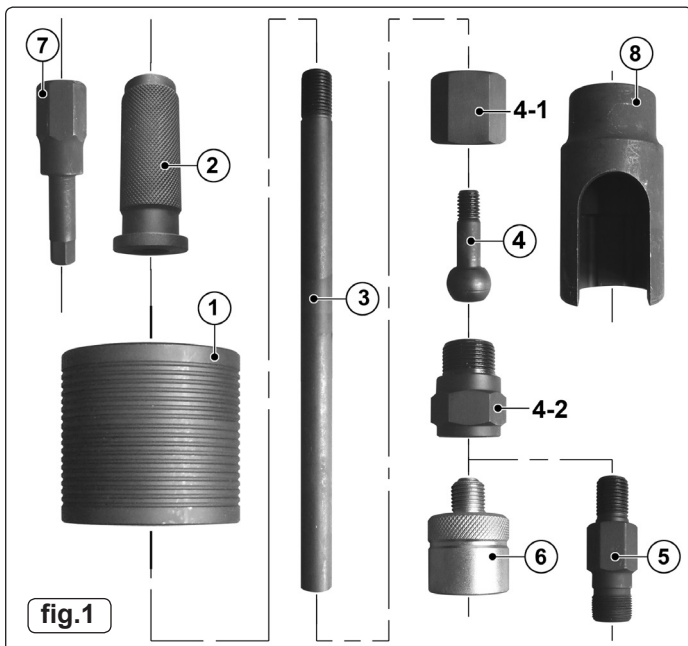

4. CONTENTS

Item	Part No:	Description
1	VS2049.01	Sliding hammer
2	VS2049.02	Handle (Length 73mm)
3	VS2049.03	Spindle Length 220mm)
4	VS2049.04	Ball type adaptor
	VS2049.04-1	Hex nut
	VS2049.04-2	Hex nut (male type)
5	VS2049.05	Adaptor (M17, Injector internal thread)
6	VS2049.06	Adaptor (M27, Injector external thread)
7	VS2049.07	Hex key M10 + M19
8	VS2049.08	M29 Socket with cut out (1/2" drive)

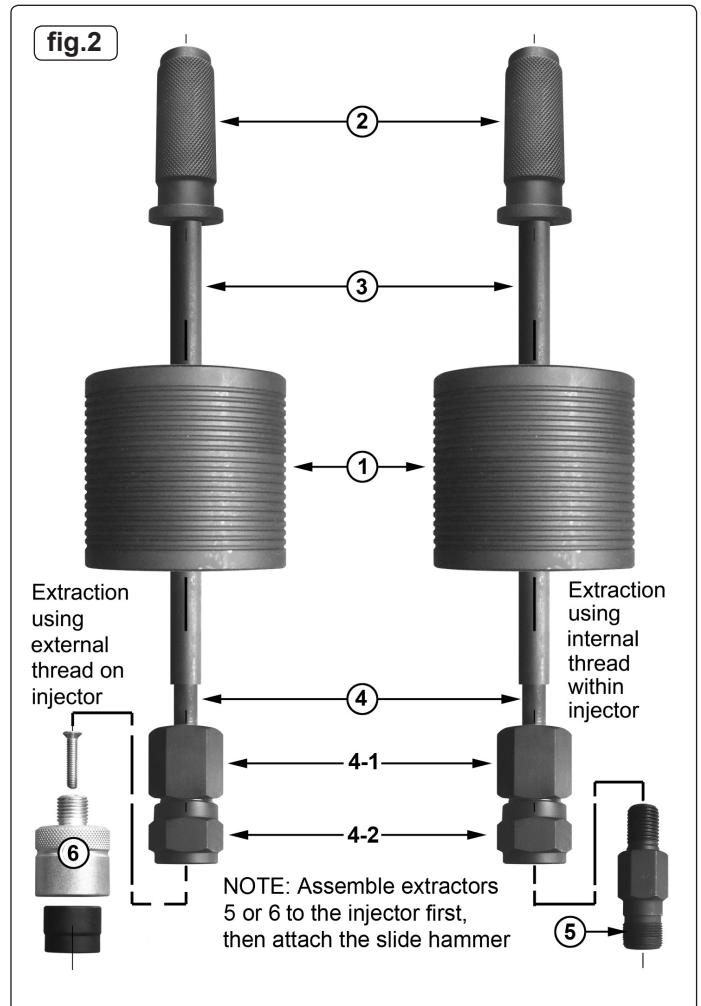

5. ASSEMBLY

- 5.1. Referring to the individual components in fig.1 assemble the Injector Puller as shown above in fig.2.
- 5.2. Use adaptor 6 when the injector is being extracted using the external thread revealed when the injector cap has been removed.
- 5.3. Use adaptor 7 when the injector is being extracted using the internal thread revealed when the inner sleeve has been removed from the injector.

6. OPERATION

NOTE: Always use the external adaptor first. If by using reasonable force the injector cannot be removed, use the internal adaptor.

- 6.1. Before working on the fuel system, make sure that the fuel system is NOT pressurised. Refer to the manufacturers instruction manual on how to check this.
- 6.2. Disconnect the injector wires as per the manufacturers instructions.
- 6.3. Remove any carbon build up from around the injector.
- 6.4. Remove the cap from the injector using the socket (8) with the cut out. Refer to fig.3A.
- 6.5. **Use of external adaptor.** (See fig.3)
 - 6.5.1. Identify the external thread adaptor (6) and separate the inner black part from the outer silver part by removing the screw from the top of the adaptor. Position the black part inside the top of the injector (see fig.3B) then place the silver part over it and screw it down firmly onto the external threads revealed when the cap was removed. Install the screw securely thus locking the adaptor parts tightly together with the injector thread and wall in between. This ensures a more secure fastening and reduces damage to the injector threads.

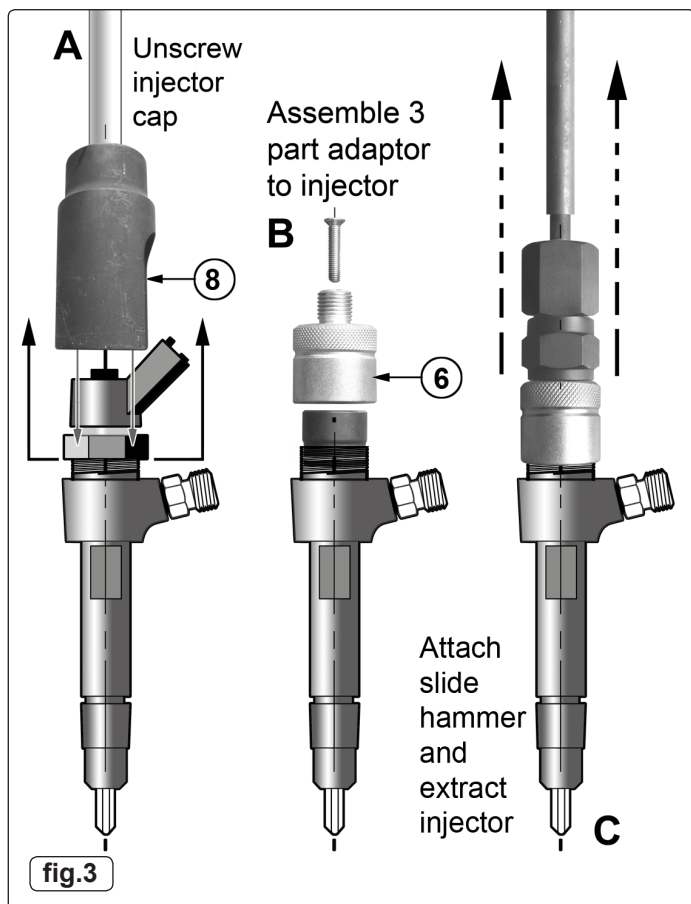

6.6. Use of internal adaptor. (See fig.4)

- 6.6.1. Remove the internal parts from the injector to gain access to use the security hex key (7). It may be necessary to remove the injector veins by force. Insert the security hex into the inner sleeve (see fig.4D). Turn the security hex anticlockwise using a 19mm socket and remove the inner sleeve.
- 6.6.2. Screw the internal adaptor (5) into the threads vacated by the inner sleeve and tighten with a 19mm spanner (See fig.4E).
- 6.7. **Removing the injector.**
 - 6.7.1. Screw the slide hammer assembly securely onto the adaptor.
 - 6.7.2. The injector can now be removed using reasonable force on the slide hammer. Be prepared for the sudden release of the injector from the cylinder head.
 - 6.7.3. If the injector cannot be removed it may be necessary to consult a main dealer or a diesel specialist to avoid damage to the engine.
 - 6.7.4. When an injector has been removed, it is recommended that only a new or refurbished injector is fitted. Follow manufacturers fitting and safety instructions.

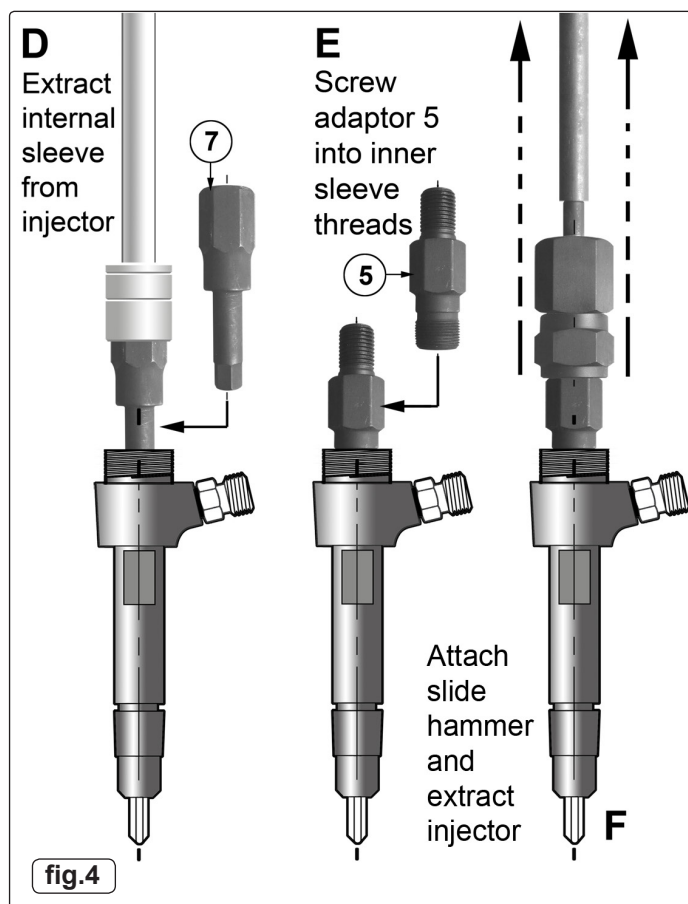

Environmental Protection



Recycle unwanted materials instead of disposing of them as waste. All tools, accessories and packaging should be sorted, taken to a recycling centre and disposed of in a manner which is compatible with the environment. When the product becomes completely unserviceable and requires disposal, drain off any fluids (if applicable) into approved containers and dispose of the product and the fluids according to local regulations.

NOTE: It is our policy to continually improve products and as such we reserve the right to alter data, specifications and component parts without prior notice.

IMPORTANT: No liability is accepted for incorrect use of this product.

WARRANTY: Guarantee is 12 months from purchase date, proof of which will be required for any claim.

SEALEY

Sole UK Distributor, Sealey Group,
Kempson Way, Suffolk Business Park,
Bury St. Edmunds, Suffolk,
IP32 7AR

01284 757500

01284 703534



www.sealey.co.uk



sales@sealey.co.uk