



INSTRUCTIONS FOR:

## VIDEO BORE SCOPE 3.9mm

MODEL No: **VS8200.V2**

Thank you for purchasing a Sealey product. Manufactured to a high standard, this product will, if used according to these instructions, and properly maintained, give you years of trouble free performance.



**IMPORTANT:** PLEASE READ THESE INSTRUCTIONS CAREFULLY. NOTE THE SAFE OPERATIONAL REQUIREMENTS, WARNINGS & CAUTIONS. USE THE PRODUCT CORRECTLY AND WITH CARE FOR THE PURPOSE FOR WHICH IT IS INTENDED. FAILURE TO DO SO MAY CAUSE DAMAGE AND/OR PERSONAL INJURY AND WILL INVALIDATE THE WARRANTY. KEEP THESE INSTRUCTIONS SAFE FOR FUTURE USE.

### 1. SAFETY

- X **DO NOT** use the bore scope if dropped and/or damaged
- X **DO NOT** operate near live electrical wires.
- X **DO NOT** operate near moving parts such as pulleys, motors, gears or fans etc.
- X **DO NOT** bend the bore scope shaft tighter than 13cm diameter.
- X **DO NOT** insert the bore scope shaft into locations whose temperature is greater than 55°C.
- ✓ Maintain the bore scope in good and clean condition for best and safest performance.
- ✓ A full range of personal safety equipment is available from your Sealey dealer.
- ✓ Wear suitable clothing to avoid snagging. Do not wear jewellery and tie back long hair.
- ✓ Account for all tools and parts being used and do not leave any in, or near, the engine.
- ✓ Be alert to your surrounding environment while using the bore scope. Note the location of the object to be inspected and determine a route to it. Bend the bore scope shaft to follow the route.

### 2. INTRODUCTION

The incredibly small probe diameters incorporated into this tool make it first choice for the diesel engine specialist where the tiny probe can be passed through most glow plug holes in the cylinder head. This makes inspection of the internal bores fast and easy. An optional side view probe is also available for this tool. The image is displayed on a crisp clear screen and can be shared using the AV cable supplied.

### 3. SPECIFICATION

Model No: .....	<b>VS8200.V2</b>
Probe ø: .....	3.9mm
Optional Probe (90° Side View) .....	VSBSP39S
Field of Vision: .....	105°
Pod Length: .....	22mm
Probe Length: .....	1100mm
Adjustable Light Control: .....	Yes
Screen Size: .....	60mm
Screen Resolution: .....	320x240
Mirror Flip/Rotate Function: .....	Yes
Record Function (Video + Still): .....	No
AV Out: .....	Yes
USB Connection: .....	No
SD Memory Slot: .....	No
Power Source: .....	4 x AA

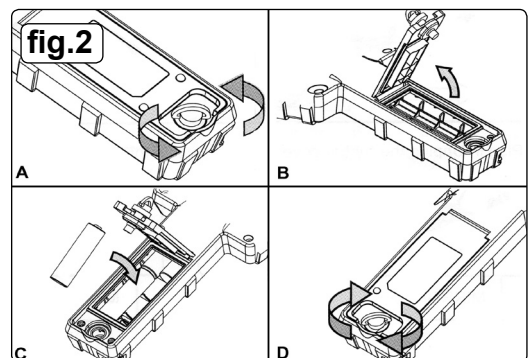
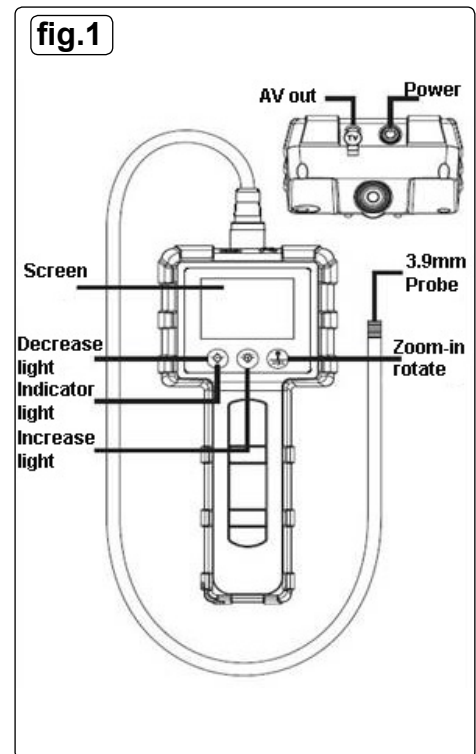

### 4. PREPARATION

#### 4.1. Batteries

- 4.1.1. Turn the bore scope over and lift up the ring screw (fig.2A) turn the ring anti-clockwise until fully unscrewed and pull to lift open the battery door (fig.2B).
- 4.1.2. Insert AA batteries ensuring correct polarity (fig.2C).
- 4.1.3. Close the battery door screw in the ring screw clockwise until tight and push down out of the way (fig.2D).

#### 4.2. Probe

- 4.2.1. Pull back the threaded sleeve on the end of the probe and ensure the red dot on the tab is facing upwards (fig.3A), take the probe and insert it into the top of the bore scope housing. The probe will only connect one way.
- 4.2.2. With the probe pushed firmly in, screw the sleeve onto the housing to secure it in place (fig.3B).

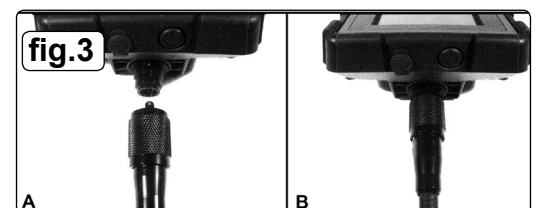

## 5. OPERATION

- X **DO NOT** use excessive force to insert or retrieve probe from the equipment or areas under inspection.
- X **DO NOT** use the probe to push against objects or to clear a path. This instrument is for remote viewing only.
- X **DO NOT** bend any part of the shaft tighter than a 130mm diameter.
- X **DO NOT** insert the probe and tip into locations where the temperature is greater than 55°C.
- X **DO NOT** vibrate, bang, or drop your bore scope. It is not shock resistant.

### 5.1. Turning On/Off

- 5.1.1. Hold the unit by the housing and press and hold down the On/Off switch (fig.4). The indicator light (fig.1) will illuminate to show the bore scope is 'on'.

### 5.2. Light Adjustment

- 5.2.1. The light on the end of the probe can be adjusted. Push the Increase/Decrease buttons (fig.5) to change the brightness, ranging from 0 - 15.

### 5.3. Zoom Function

- 5.3.1. Push the 'Zoom' button (fig.6) to increase the picture on screen x 1.5. Push again to return to default viewing.

### 5.4. Rotation Function

- 5.4.1. Push and hold the rotate button (fig.6) for 3 seconds, the image on screen will rotate horizontally and an 'M' will appear in the top left of the screen. Push and hold the button again to return to the default screen.

### 5.5. Video Out Port

- 5.5.1. The bore scope provides an external video signal via an RCA phono jack (fig.4). This signal can be utilized by a compatible monitor or recording device. (AV Lead Included).  
**WARNING!** The handheld monitor unit is not water resistant. The shaft and tip are water resistant.

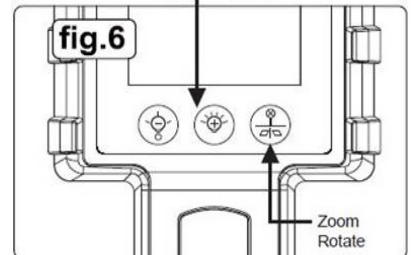
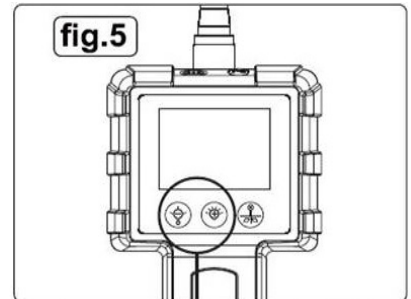
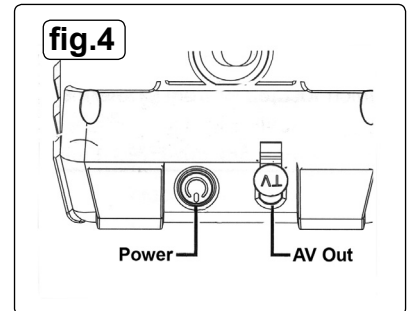

## 6. MAINTENANCE

### 6.1 Battery Replacement

- 6.1.1 Turn the bore scope over and lift up the ring screw (fig.2A) turn the ring anti-clockwise until fully unscrewed and pull to lift open the battery door (fig.2B).  
 6.1.2 Remove exhausted batteries and Insert new AA batteries, ensuring correct polarity (fig.2C).  
 6.1.3 Close the battery door, screw in the ring screw clockwise until tight and push down out the way (fig.2D).

### 6.2 Cleaning and Storage

- 6.2.1 Wipe the probe tip, shaft and housing with a clean, soft cloth to remove residue and moisture.  
 6.2.2 Wash the probe tip and shaft with a cleaning liquid and rinse with water, then dry.  
 6.2.3 Clean the probe lens gently with a lens cleaner (such as isopropyl alcohol) and a cotton bud.

- X **DO NOT submerge the bore scope in water - the bore scope monitor is not water resistant.**  
**NOTE: The bore scope MUST be completely dry prior to returning it to the storage case.**

### Environmental Protection.



Recycle unwanted materials instead of disposing of them as waste.

All tools, accessories and packaging should be sorted, taken to a recycle centre and disposed of in a manner which is compatible with the environment.



When the product is no longer required, it must be disposed of in an environmentally protective way. Contact your local solid waste authority for recycling information.

### Battery Removal.

- Refer to Section 6.1 for battery removal.

**Dispose of batteries according to local authority guidelines.**

Under the Waste Batteries and Accumulators Regulations 2009, Jack Sealey Ltd are required to inform potential purchasers of products containing batteries (as defined within these regulations), that they are registered with Valpak's registered compliance scheme. Jack Sealey Ltd's Batteries Producer Registration Number (BPRN) is BPRN00705

**Parts support is available for this product. To obtain a parts listing and/or diagram, please log on to [www.sealey.co.uk](http://www.sealey.co.uk), email [sales@sealey.co.uk](mailto:sales@sealey.co.uk) or phone 01284 757500.**

**NOTE:** It is our policy to continually improve products and as such we reserve the right to alter data, specifications and component parts without prior notice.

**IMPORTANT:** No liability is accepted for incorrect use of this product.

**WARRANTY:** Guarantee is 12 months from purchase date, proof of which will be required for any claim.



**Sole UK Distributor, Sealey Group,**  
 Kempson Way, Suffolk Business Park,  
 Bury St. Edmunds, Suffolk,  
 IP32 7AR

01284 757500

01284 703534

[www.sealey.co.uk](http://www.sealey.co.uk)

[sales@sealey.co.uk](mailto:sales@sealey.co.uk)