

INSTRUCTIONS FOR:

REAR SUBFRAME BUSH TOOL - BMW 5 SERIES

Model No: **VSE5580**

Thank you for purchasing a Sealey product. Manufactured to a high standard this product will, if used according to these instructions and properly maintained, give you years of trouble free performance.



IMPORTANT: READ THESE INSTRUCTIONS CAREFULLY. NOTE THE SAFE OPERATIONAL REQUIREMENTS, WARNINGS AND CAUTIONS. USE THE TOOL CORRECTLY AND WITH CARE FOR THE PURPOSE FOR WHICH IT IS INTENDED. FAILURE TO DO SO MAY CAUSE DAMAGE AND/OR PERSONAL INJURY AND WILL INVALIDATE THE WARRANTY. PLEASE KEEP INSTRUCTIONS SAFE FOR FUTURE USE

1. SAFETY INSTRUCTIONS

- WARNING!** Ensure Health and Safety, local authority and general workshop practice regulations are adhered to when using tools.
- DO NOT** use tools if damaged.
- Maintain tools in good and clean condition for best and safest performance.
- Ensure that a vehicle which has been jacked up is adequately supported with axle stands and that the wheels are chocked, refer to the vehicle manufacturer's service instructions, or a proprietary manual.
- Wear approved eye protection. A full range of personal safety equipment is available from your Sealey dealer.
- Wear suitable clothing to avoid snagging. Do not wear jewellery and tie back long hair.
- DO NOT** use air tools to operate the force screw.
- IMPORTANT:** The force screw must be kept well lubricated.

IMPORTANT: This manual is provided as a guide only, refer to the vehicle manufacturer's service instructions, or a proprietary manual, to establish the current procedure and data.

- WARNING!** Failure to heed safety and warning instructions may result in damage and/or personal injury and will invalidate the warranty.
- WARNING!** The warnings, cautions and instructions referred to in this manual cannot cover all possible conditions and situations that may occur. It must be understood that common sense and caution are factors which cannot be built into this product, but must be applied by the operator.

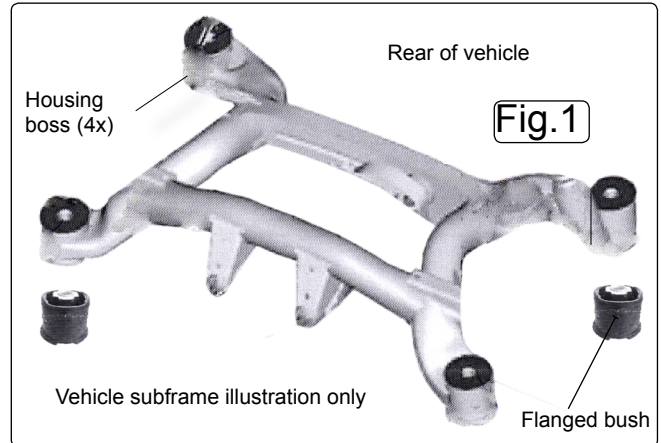

3. OPERATION

NOTE! Illustration of the sub frame removed from the vehicle for clarity. Refer to the vehicle manufacturer's service instructions, or a proprietary manual to carry this out.

NOTE! This tool will insert the bush to the correct depth, but before installing the new bush, refer to the vehicle manufacturer's service instructions, or a proprietary manual, to establish the correct horizontal alignment/positioning of the bush.

IMPORTANT: This tool is designed to aid removal of the bush.

- We suggest that the area around the bush is thoroughly cleaned.
- The threads of the tool should also be thoroughly lubricated in use.
- **An Impact Socket must NOT be used with this tool.**
- **Stripped threads and bent thrust cups are not accepted warranty claims on this tool.**

3.1. Removing Bush

- 3.1.1. Assemble the removal (black) set as in Fig.3. Thread the Adaptor (A) onto the short threaded end of the bolt (F) with the boss adjacent to thread shoulder. Pass the bolt through the bush from above, rotate to register machined flats and then position the barrel Adaptor (B) over the bolt. Fit the barrel Adaptor (B) against the housing face with the recess fitted over the location on the bush and or housing. Thread the ball race nut (E) on to the projecting bolt and wind it up to the barrel Adaptor (B) flat face with ball race leading. Check axis alignment prior to full force extraction.

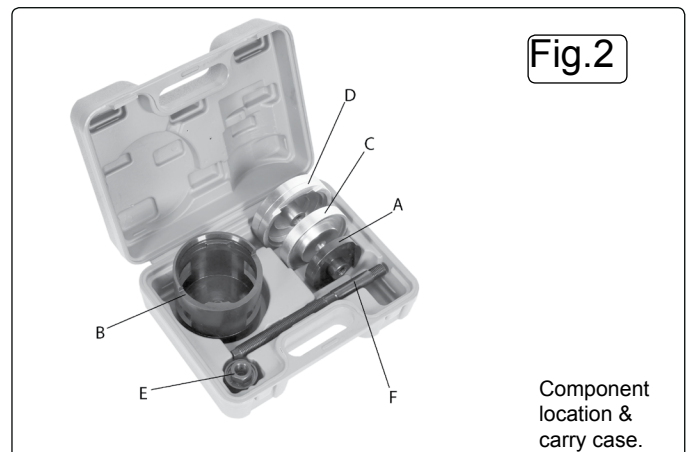

ALWAYS KEEP FORCE SCREW WELL LUBRICATED. MOLYBDENUM/ COPPER BASED RECOMMENDED.

DO NOT USE AIR TOOLS OR IMPACT SOCKET.

Force screw maximum load 150Nm. Exceeding this load will shorten the life of the force screw. The force screw is considered to be a consumable item and is NOT covered under warranty.

2. INTRODUCTION & APPLICATIONS

Suitable for the removal / installation of the rear axle carrier bushes. Can be used in situ without the need to remove the rear subframe assembly from the vehicle. Use the tool with a 24mm spanner only.

Applications:

- **BMW:** E39 5 Series Saloon (95 - 05)
- **OEM Bush No 33311091422**

- 3.1.2. Using a 24mm spanner, turn the nut clockwise. The extractor will start to extract the bush through the housing (Fig.3).
- 3.1.3. Keep turning until the bush has been extracted all the way out of the housing. Take care as the bush and assembly will fall away when the bush is fully removed.
- NOTE!** If any undue resistance is felt, remove the assembly and check everything is correctly aligned. The bush will only push out in one direction.

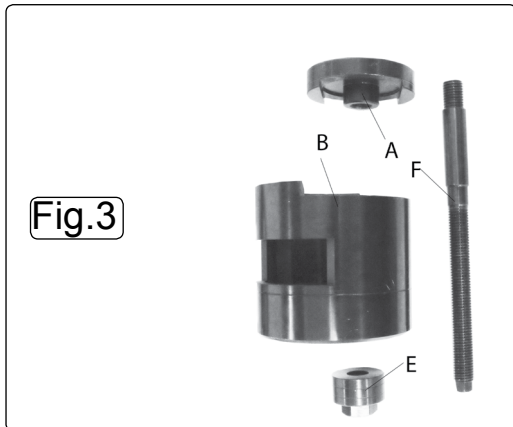

Composite section through housing boss (4 places)

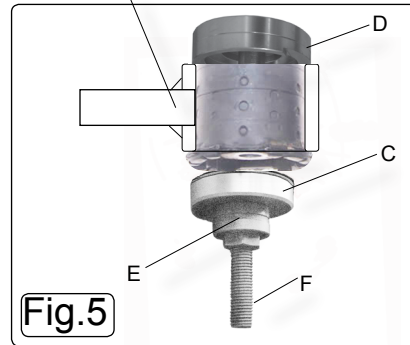

- 3.2.3. Using a 24mm spanner, turn the nut clockwise. The bush will start to enter into the housing (Fig.4)
- NOTE!** If any undue resistance is felt, remove the assembly and check that everything is correctly aligned.
- 3.2.4. Continue to turn the nut to install the bush, when the bush is fully seated, solid resistance will be felt and the bush is now fully installed (Fig.5).
- 3.2.5. Disassemble the tool, clean and lubricate before returning the parts to the storage case.
- 3.2.6. Re-fit all the components as per the vehicle manufacturer's service instructions or a proprietary manual.

3.2. Installing new bush.

- 3.2.1. Before installing a new bush, clean the inside of the housing.

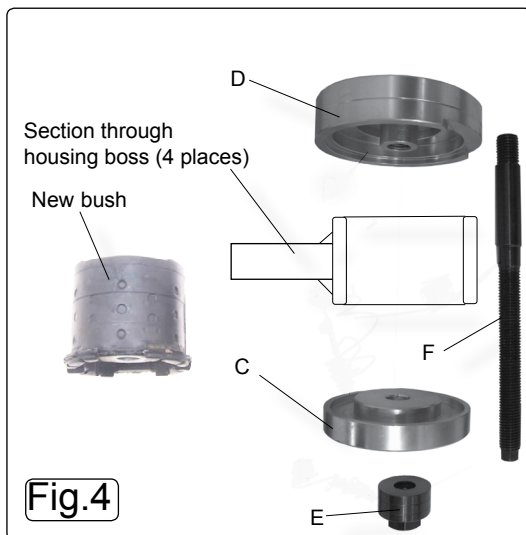

- 3.2.2. Assemble the silver disc Adaptor (D) on the threaded rod, with internal boss adjacent to shoulder, orientation as in Fig.4 - viewed from below. Pass the bolt through the housing from the top, through the presented bush and then position the silver disc Adaptor (C) over the bolt with the internal boss uppermost, fitting it against the bush.

To facilitate correct positioning of the bush, the installation Adaptor (C) has a boss and recess that align with the face of the new bush. The bush should then be aligned in the housing so that the bush is facing directly upwards (Fig.4). Thread the ball race nut (E) onto the bolt and wind it up to the adaptor. Check to make sure that everything is aligned on the housing axis and that the bush is sitting squarely against the housing machined face.

Parts support is available for this product. To obtain a parts listing and/or diagram, please log on to www.sealey.co.uk, email sales@sealey.co.uk or phone 01284 757500.

NOTE: It is our policy to continually improve products and as such we reserve the right to alter data, specifications and component parts without prior notice.

IMPORTANT: No liability is accepted for incorrect use of this product.

WARRANTY: Guarantee is 12 months from purchase date, proof of which will be required for any claim.

INFORMATION: For a copy of our latest catalogue and promotions call us on 01284 757525 and leave your full name and address, including postcode.

SEALEY Professional TOOLS
Auto Service Line

Sole UK Distributor, Sealey Group,
Kempson Way, Suffolk Business Park,
Bury St. Edmunds, Suffolk,
IP32 7AR

01284 757500
01284 703534

www.sealey.co.uk
sales@sealey.co.uk