

Parts Information:
Air Operated Folding Jack 15-30tonne
Telescopic
Model No: YAJ15-30F.V2

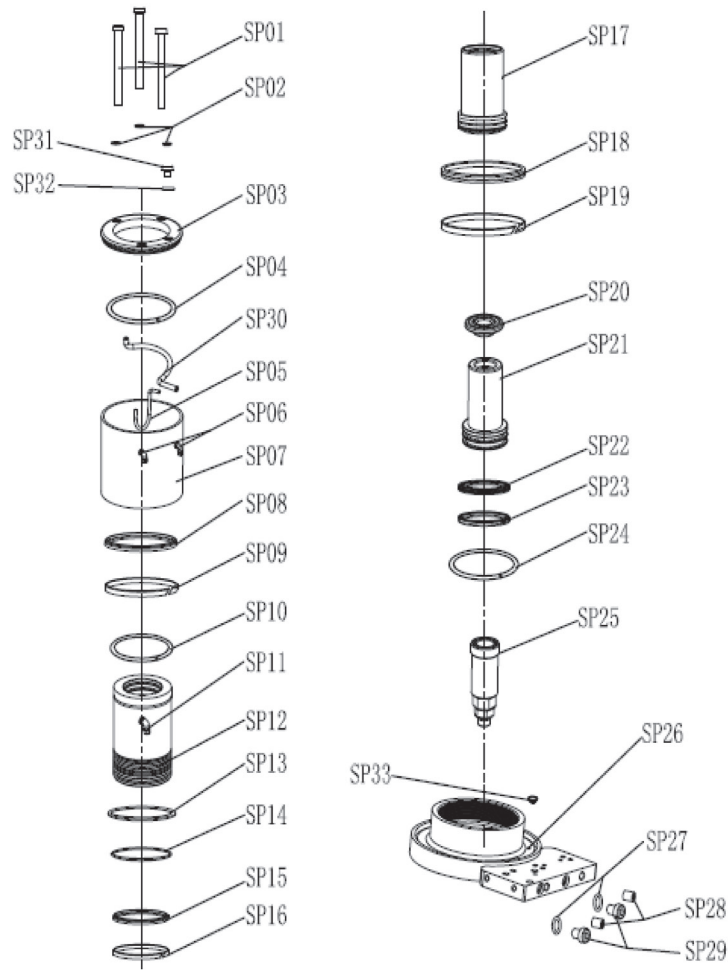

Item	Part No.	Description
SP01	YAJ1530F.SP01	Screw
SP02	YAJ1530F.SP02	Spacer
SP03	YAJ1530F.SP03	Oil Tank Cover
SP04	YAJ1530F.SP04	O-Ring
SP05	YAJ1530F.SP05	Air Hose
SP06	YAJ1530F.SP06	Elbow
SP07	YAJ1530F.SP07	Oil Tank
SP08	YAJ1530F.SP08	Dustproof Ring
SP09	YAJ1530F.SP09	Guide Ring
SP10	YAJ1530F.SP10	O-Ring
SP11	YAJ1530F.SP11	Elbow
SP12	YAJ1530F.SP12	Outer Sleeve
SP13	YAJ1530F.SP13	Locking Ring
SP14	YAJ1530F.SP14	O-Ring
SP15	YAJ1530F.SP15	Dustproof Ring
SP16	YAJ1530F.SP16	Guide Ring
SP17	YAJ1530F.SP17	Inner Sleeve

Item	Part No.	Description
SP18	YAJ1530F.SP18	Seal (XTP)
SP19	YAJ1530F.SP19	Guide Ring
SP20	YAJ1530F.SP20	Saddle
SP21	YAJ1530F.SP21	Piston
SP22	YAJ1530F.SP22	Seal (XTP)
SP23	YAJ1530F.SP23	Guide Ring
SP24	YAJ1530F.SP24	O-Ring
SP25	YAJ1530F.SP25	Height Limit System
SP26	YAJ1530F.SP26	Base
SP27	YAJ1530F.SP27	O-Ring
SP28	YAJ1530F.SP28	Screw Nut
SP29	YAJ1530F.SP29	Screw Nut
SP30	YAJ1530F.SP30	Air Hose
SP31	FUSN-SP31	Csk Socket Machine Screw
SP32	FUSN-SP32	O-Ring
SP33	FUSN-SP33	Filter

NOTE: It is our policy to continually improve products and as such we reserve the right to alter data, specifications and component parts without prior notice.

IMPORTANT: No liability is accepted for incorrect use of product.

WARRANTY: Guarantee is 12 months from purchase date, proof of which will be required for any claim.

Parts Information:
Air Operated Folding Jack 15-30tonne
Telescopic
Model No: YAJ15-30F.V2

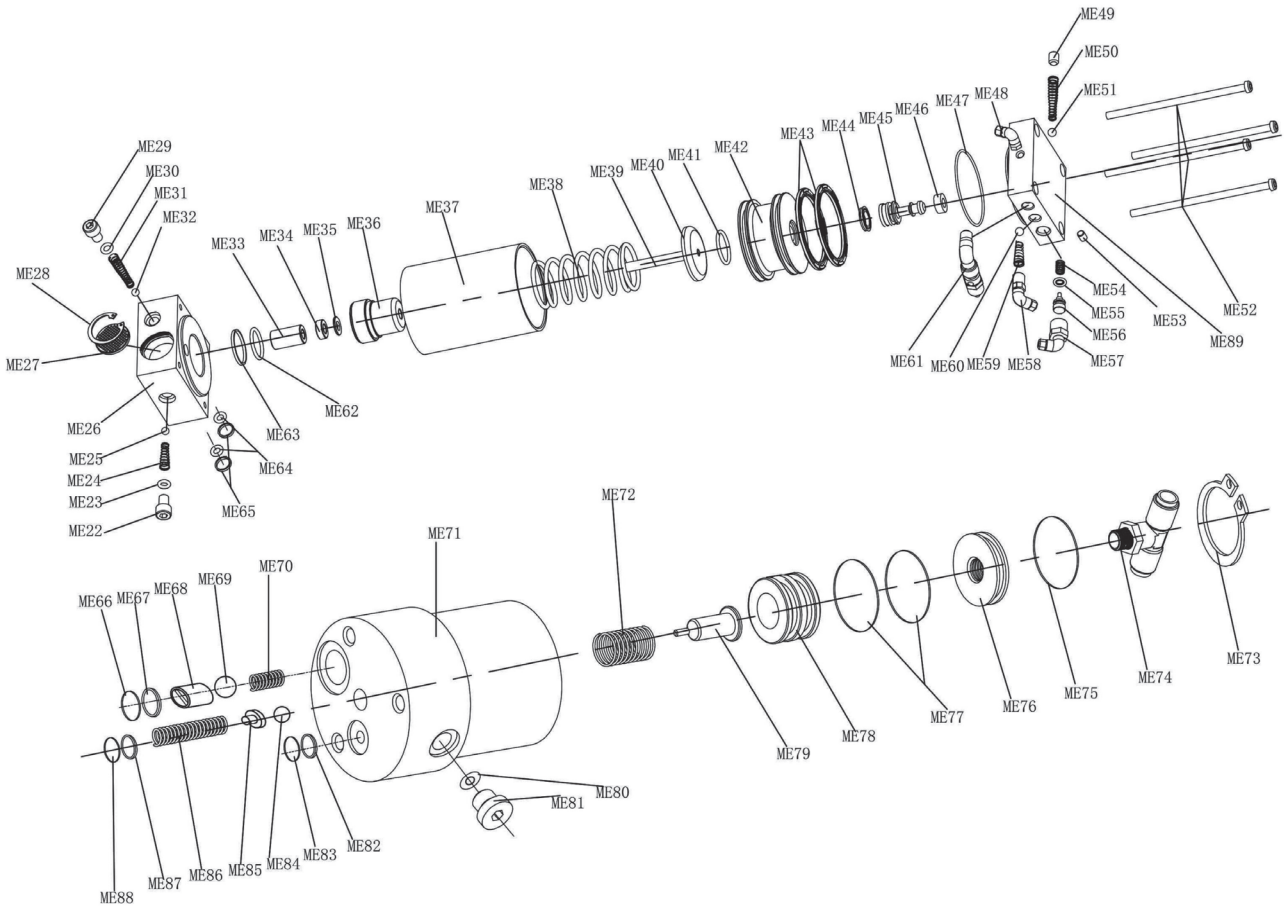

Item	Part No.	Description
ME22	YAJ1530F.ME22	Csk Socket Machine Screw
ME23	YAJ1530F.ME23	O-Ring
ME24	YAJ1530F.ME24	Spring
ME25	YAJ1530F.ME25	Steel Ball
ME26	YAJ1530F.ME26	Check Valve
ME27	YAJ1530F.ME27	Silencer
ME28	YAJ1530F.ME28	Retaining Ring
ME29	YAJ1530F.ME22	Csk Socket Machine Screw
ME30	YAJ1530F.ME30	O-Ring
ME31	YAJ1530F.ME31	Spring
ME32	YAJ1530F.ME32	Steel Ball
ME33	YAJ1530F.ME33	Guide Bushing
ME34	YAJ1530F.ME34	Spacer
ME35	YAJ1530F.ME35	Seal
ME36	YAJ1530F.ME36	Plunger Bushing
ME37	YAJ1530F.ME37	Air Cylinder
ME38	YAJ1530F.ME38	Spring
ME39	YAJ1530F.ME39	Plunger Rod Ass'Y (c/w Plunger Cover ME40)
ME40	YAJ1530F.ME40	Plunger Cover
ME41	YAJ1530F.ME41	O-Ring

Item	Part No.	Description
ME42	YAJ1530F.ME42	Piston
ME43	YAJ1530F.ME43	Sealing (PK)
ME44	YAJ1530F.ME44	Sealing (OE)
ME45	YAJ1530F.ME45	Piston
ME46	YAJ1530F.ME46	Rubber Cap
ME47	YAJ1530F.ME47	O-Ring
ME48	YAJ1530F.ME48	Elbow
ME49	YAJ1530F.ME49	Grub Screw
ME50	YAJ1530F.ME50	Spring
ME51	YAJ1530F.ME51	Rubber Ball
ME52	YAJ1530F.ME52	Screw
ME53	YAJ1530F.ME53	Grub Screw
ME54	YAJ1530F.ME54	Spring
ME55	YAJ1530F.ME55	O-Ring
ME56	YAJ1530F.ME56	Piston
ME57	YAJ1530F.ME57	T-Piece
ME58	YAJ1530F.ME58	Elbow
ME59	YAJ1530F.ME59	Spring
ME60	YAJ1530F.ME60	Rubber Ball
ME61	YAJ1530F.ME61	Elbow
ME62	YAJ1530F.ME62	O-Ring
ME63	YAJ1530F.ME63	Locking Ring
ME64	YAJ1530F.ME64	O-Ring
ME65	YAJ1530F.ME65	Locking Ring

Item	Part No.	Description
ME66	YAJ1530F.ME66	Locking Ring
ME67	YAJ1530F.ME67	Locking Ring
ME68	YAJ1530F.ME68	Steel Ball Seat
ME69	YAJ1530F.ME69	Steel Ball
ME70	YAJ1530F.ME70	Spring
ME71	YAJ1530F.ME71	Oil Drain Valve
ME72	YAJ1530F.ME72	Spring
ME73	YAJ1530F.ME73	Retaining Ring
ME74	YAJ1530F.ME74	T-Piece Connector
ME75	YAJ1530F.ME75	O-Ring
ME76	YAJ1530F.ME76	End Cover
ME77	YAJ1530F.ME77	O-Ring
ME78	YAJ1530F.ME78	Oil Drain Piston
ME79	YAJ1530F.ME79	Oil Drain Bolt
ME80	YAJ1530F.ME80	O-Ring
ME81	YAJ1530F.ME22	Screw Nut
ME82	YAJ1530F.ME82	Locking Ring
ME83	YAJ1530F.ME83	O-Ring
ME84	YAJ1530F.ME84	Steel Ball
ME85	YAJ1530F.ME85	Spring Base
ME86	YAJ1530F.ME86	Spring
ME87	YAJ1530F.ME87	Locking Ring
ME88	YAJ1530F.ME88	O-Ring
ME89	YAJ1530F.ME89	Air Inlet Base



Parts Information:
Air Operated Folding Jack 15-30tonne
Telescopic
Model No: YAJ15-30F.V2

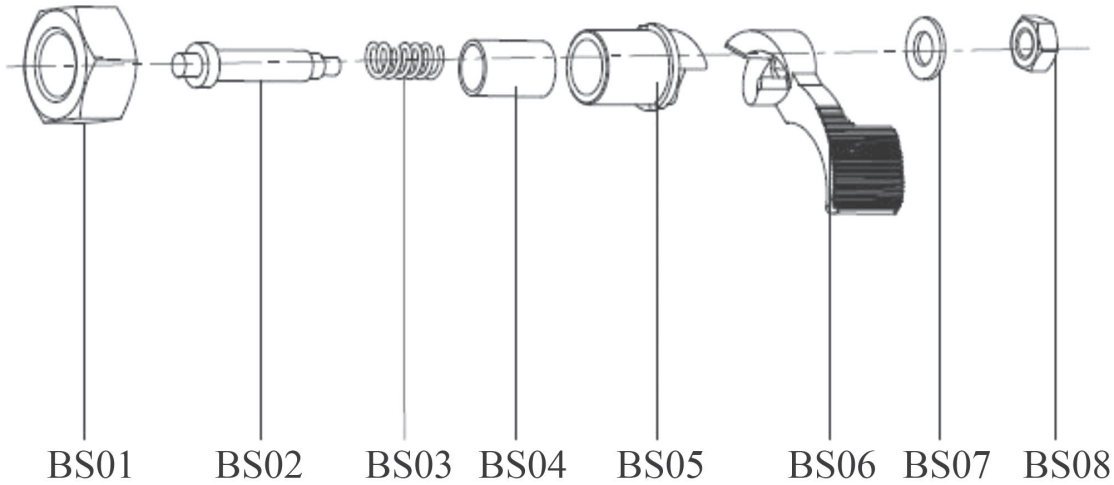

BS01

BS02

BS03

BS04

BS05

BS06

BS07

BS08

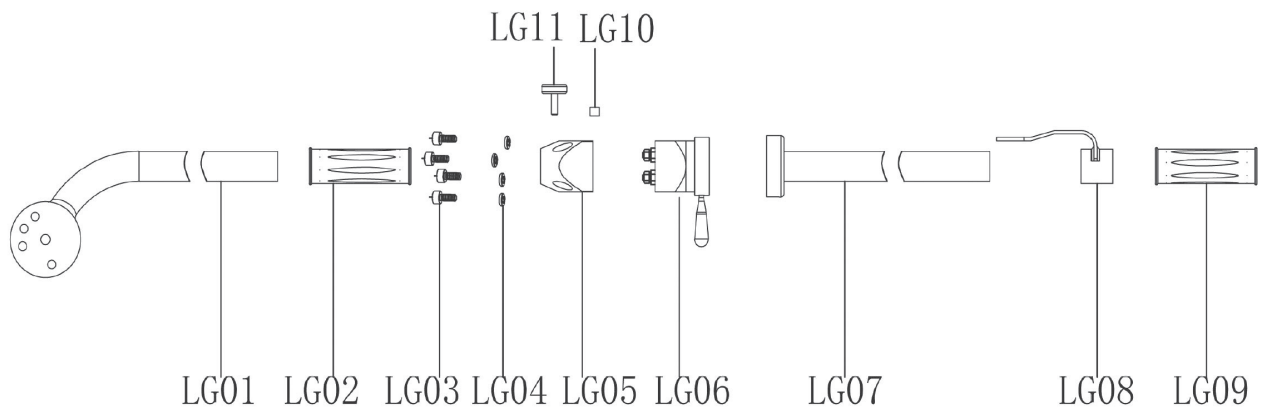

LG01

LG02

LG03

LG04

LG05

LG06

LG07

LG08

LG09

LG11 LG10

Item	Part No.	Description
BS01	YAJ1530F.BS01	Half Nut (Fine Thread)
BS02	YAJ1530F.BS02	Position Pin
BS03	YAJ1530F.BS03	Spring
BS04	YAJ1530F.BS04	Inner Guide
BS05	YAJ1530F.BS05	Outer Guide
BS06	YAJ1530F.BS06	Knob
BS07	YAJ1530F.BS07	Spacer
BS08	NLN6.S	Nyloc Nut M6 Zinc Din 985 (Single)
LG01	YAJ1530F.LG01	Handle Level
LG02	YAJ1530F.LG02	Grip

Item	Part No.	Description
LG03	YAJ1530F.LG03	Screw
LG04	YAJ1530F.LG04	Spacer
LG05	YAJ1530F.LG05	Switch Base
LG06	YAJ1530F.LG06	Switch Assy
--	YAJ20-40.78	Handle (not shown)
LG07	YAJ1530F.LG07	Handle Level Ass'y (inc.LG08/LG09)
LG08	YAJ1530F.LG08	Fixed Sets
LG09	YAJ1530F.LG09	Grip
LG10	YAJ1530F.LG10	Screw
LG11	YAJ1530F.LG11	Screw

NOTE: It is our policy to continually improve products and as such we reserve the right to alter data, specifications and component parts without prior notice.

IMPORTANT: No liability is accepted for incorrect use of product.

WARRANTY: Guarantee is 12 months from purchase date, proof of which will be required for any claim.

Sealey Group, Kempson Way, Suffolk Business Park, Bury St Edmunds, Suffolk. IP32 7AR



01284 757500



01284 703534



sales@sealey.co.uk



www.sealey.co.uk

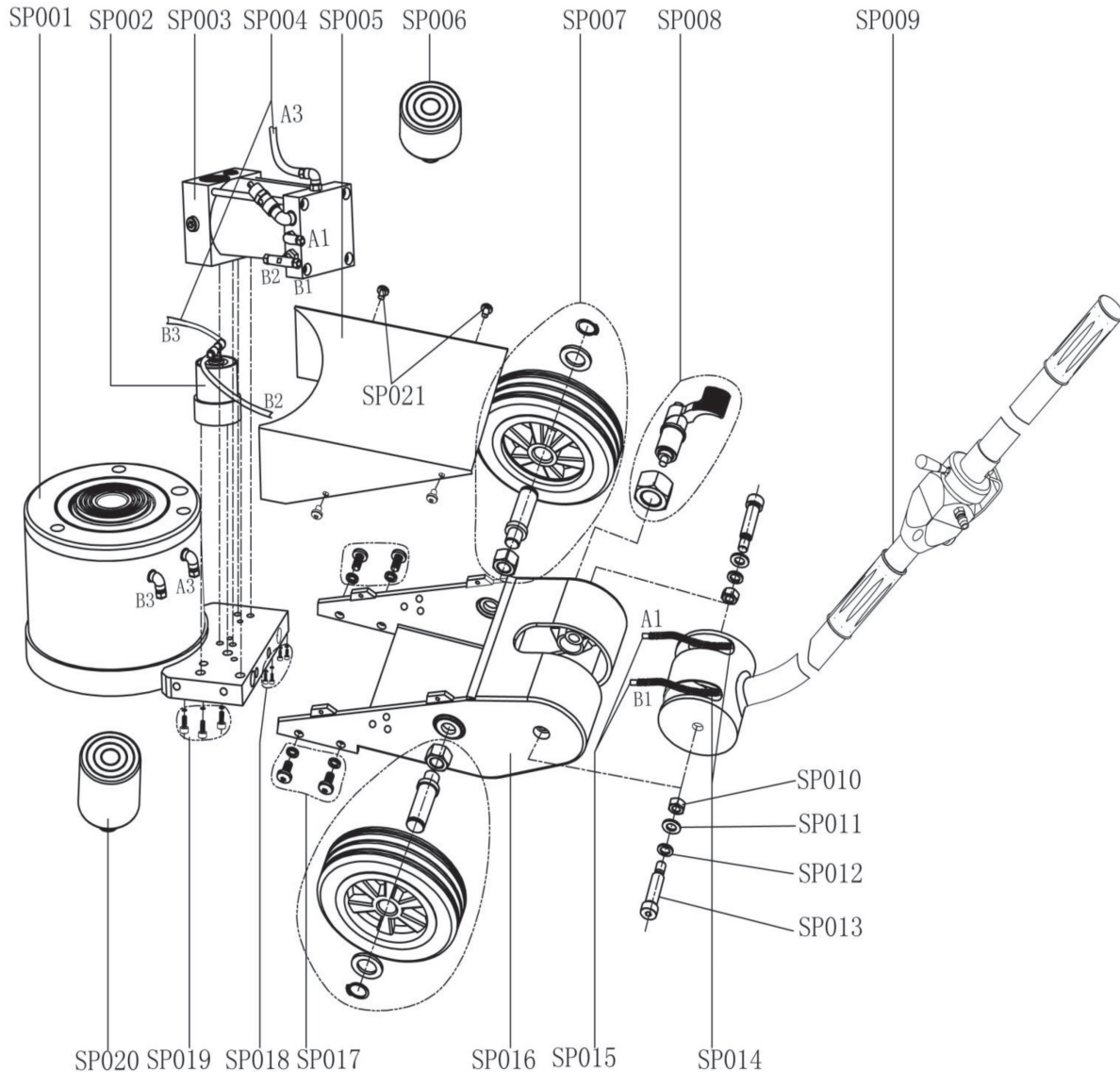

Item	Part No.	Description
SP001	YAJ1530FSP001	Oil Cylinder Ass'y
SP002	YAJ1530FSP002	Oil Drain Valve Ass'y
SP003	YAJ1530FSP003	Pump Ass'y
SP004	YAJ1530FSP004	Air Hose 4mm x 6mm x 1000mm (1 metre)
SP005	YAJ1530FSP005	Tank Cover
SP006	YAJ1530FSP006	Adaptor 45mm
SP007	YAJ1530FSP007	Wheel, Fixed, c/w Fixings (D:160 W:44 B:21)
SP008	YAJ1530FSP008	Adjustable Foot
SP009	YAJ1530FSP009	Handle Ass'y
SP010	SN38.UNCB	Steel Nut 3/8" Unc Black (Single)

Item	Part No.	Description
SP011	YAJ1530FSP011	Spacer
SP012	SWM10.SB	Spring Washer M10 Black(Single)
SP013	YAJ1530FSP013	Screw
SP014	YAJ1530FSP014	Spring
SP015	YAJ1530FSP015	Air Hose 4mm x 6mm x 1000mm (1 metre)
SP016	YAJ1530FSP016	Tank
SP017	BHSS816.SB	Button Head Socket Screw M8x16 Black
SP018	SCB8130.SB	Socket Head Cap Screw M8x130 Black
SP019	SCB820.SB	Socket Head Cap Screw M8x20 Black
SP020	YAJ1530FSP020	Adaptor 75mm

NOTE: It is our policy to continually improve products and as such we reserve the right to alter data, specifications and component parts without prior notice.

IMPORTANT: No liability is accepted for incorrect use of product.

WARRANTY: Guarantee is 12 months from purchase date, proof of which will be required for any claim.