

HP-ESR Weigh Scale Pallet Truck

Features:

High accuracy.

Maximum error 0.1% of scale capacity, even with floor conditions that are not optimal or when a load is placed out of centre. The accuracy remains high.

Totalising function.

Adds up multiple pallet weights to a total weight per shipment or order, also for avoiding overloads. When a weight is added, the display shows the new total weight and the number of pallets weighed. This permits the user to verify that he did not forget to weigh any pallets or weighed the same pallet twice.

High battery autonomy

Four standard AA-batteries (2.7Ah) allow 70 hours of use. The automatic sleep mode assures that 4200 weighing actions can be taken. In most common use this means that batteries will have to be changed* only one time per year (*or charged if rechargeable batteries are used).

High contrast display.

Display can be read from any angle: when operator is standing near the pallet for dosing, or for adding products to the pallet by weight. The display does not need a backlight because it reads extremely well at ambient light conditions.

Big function keys that "click".

When pushing the function keys, the operator senses a "click" movement. Even when working with gloves, the operator feels whether he has pressed the key properly.

High reliability: all components are designed for mobile use

Electronics are compact and have low power consumption. No connectors or components that can shake loose from shocks or vibrations. Long product life and low cost of ownership.

Water and dust proof to norm IP65.

One of the most important characteristics for a reliable mobile scale. IP65 means that the pallet truck scale can be used outside or on lorries and be cleaned with water (but not by high pressure!!!) The load cells in the forks have an even higher protection level.

Product is CE conform for Europe and FCC conform for the USA.

OPTIONAL:

Thermal Printer

Printer which is reliable in mobile applications. Use of printer does hardly influence the life time of the batteries. The printer is protected for use at low battery voltage levels. The printer is also resistant to vibrations and shocks.



MIDLAND PALLET TRUCKS LTD

Part of the Midland Group of Companies

Building 33 Second Avenue, Pensnett Trading Estate, Kingswinford

West Midlands. DY6 7UG

Telephone 01384 841440

Fax 01384 841450

Email. sales@midlandpallettrucks.com

HP-ESR Weigh Scale Pallet Truck



This versatile and mobile weigh scale pallet truck will operate as a standard pallet truck with the added facility of a being able to check weigh pallets as and when required.

The unit is fitted with the Easy to use digital terminal which offers standard functions such as Zero, Tare, Clear, and displays in single Kilo increments up to 2000 kg changeable to pounds.

The truck works on 4 x 1.5V AA-batteries

Low battery indicator with auto shut off function after 3 minutes of inactivity.

Four load cells allow for a stable reading to be registered with an accuracy of +/- 2kg in 2000kg

The truck is based on our AC25 heavy-duty 2500kg capacity frame and pump unit with a powder coated paint finish.

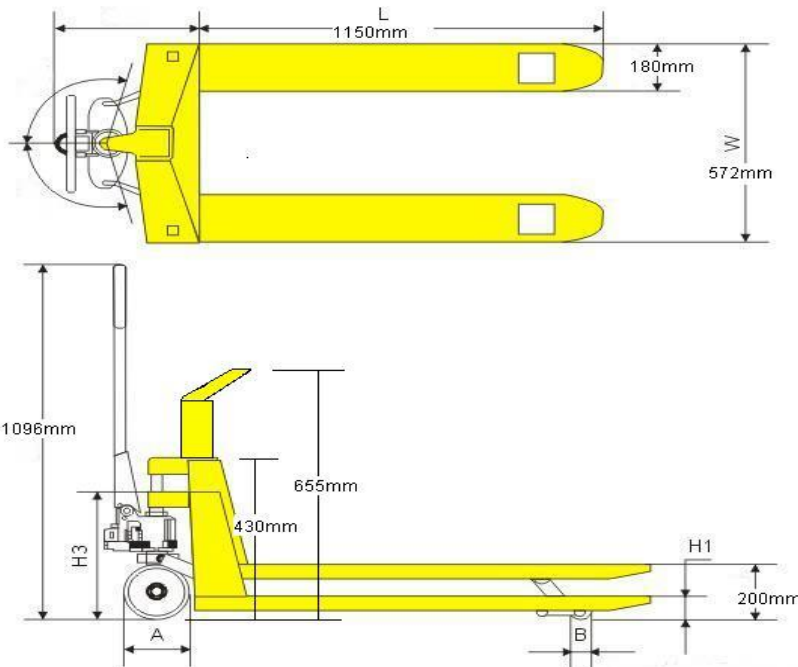

Four load cells allow for a stable reading to be registered with an accuracy of +/- 2kg in 2000kg

The truck is based on our AC25 heavy-duty 2500kg capacity frame and pump unit with a powder coated paint finish.



Polyurethane wheels fitted as standard with double rollers on the forks.

Battery charger with 4 rechargeable batteries Available for this unit.

ITEM / TYPE	SAC-W	
Capacity	kg	2000
Min Fork Height	(H1) mm	85
Max Fork Height	(H2) mm	200
Fork Size WxH	mm	182x50
Fork Length	(L) mm	1150
Width over Forks	(W) mm	572
Battery	4 x AA	1.5V
		Not rechargeable



MIDLAND PALLET TRUCKS LTD
Part of the Midland Group of Companies
Building 33 Second Avenue, Pensnett Trading Estate, Kingswinford
West Midlands. DY6 7UG
Telephone 01384 841440
Fax 01384 841450
Email. sales@midlandpallettrucks.com